

## Chapter 2: State of Hydropower in the United States

<https://www.energy.gov/eere/water/articles/hydropower-vision-new-chapter-america-s-1st-renewable-electricity-source>

# Hydropower VISION

A New Chapter for America's **1<sup>st</sup>** Renewable Electricity Source



U.S. DEPARTMENT OF  
**ENERGY**



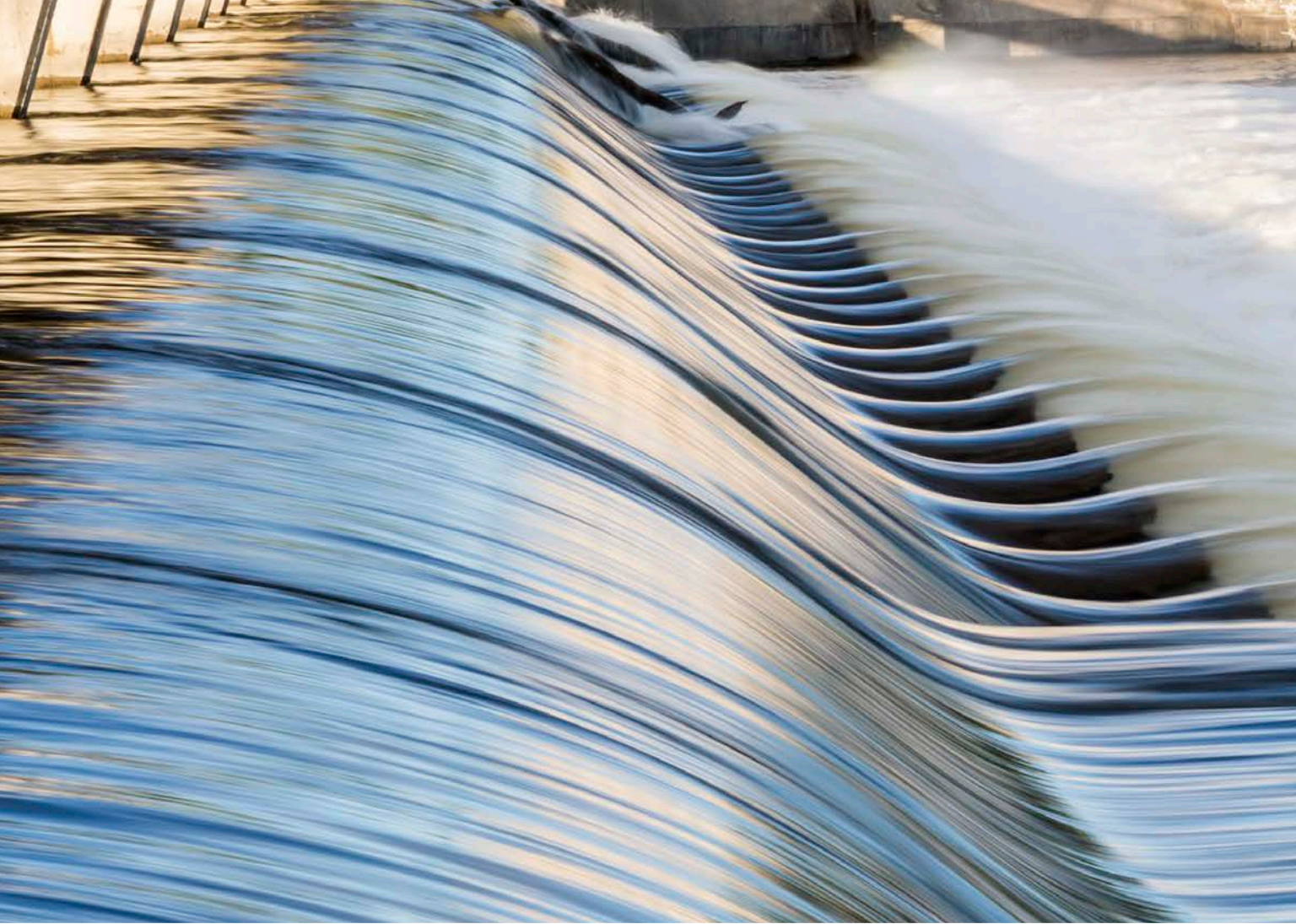

# 2

## STATE OF HYDROPOWER in the United States

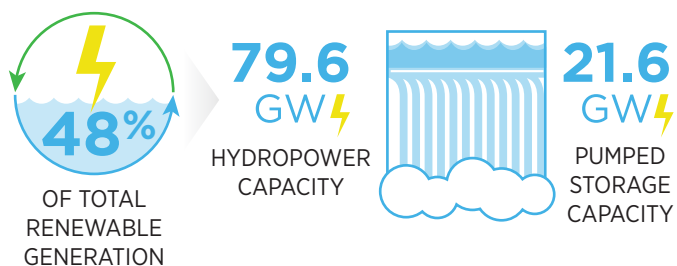

Photo from iStock 65681751. Illustration by Joshua Bauer/NREL



## Overview

Hydropower is the primary source of renewable energy generation in the United States, delivering 48% of total renewable electricity sector generation in 2015, and roughly 62% of total cumulative renewable generation over the past decade (2006-2015) [1]. The approximately 101 gigawatts<sup>1</sup> (GW) of hydropower capacity installed as of 2014 included ~79.6 GW from hydropower generation<sup>2</sup> facilities and ~21.6 GW from pumped storage<sup>3</sup> facilities [2]. Reliable generation and grid support services from hydropower help meet the nation's requirements for the electrical bulk power system, and hydropower provides a long-term, renewable source of energy that is essentially free of hazardous waste and is low in carbon emissions. Hydropower also supports national energy security, as its fuel supply is largely domestic.



**Hydropower is the largest renewable energy resource in the United States and has been an established, reliable contributor to the nation's supply of electricity for more than 100 years.**

In the early 20th century, the environmental consequences of hydropower were not well characterized, in part because national priorities were focused on economic development and national defense. By the latter half of the 20th century, however, there was greater awareness of the environmental impacts of dams, reservoirs, and hydropower operations.

As a result, the federal government passed laws that have led to safer and more environmentally aware operation of dams, reservoirs, and hydropower facilities throughout the nation.

Decades of evolution in engineering technologies, environmental mitigation and protection methods, and regulatory frameworks provide a foundation for future hydropower. Five primary potential resource classes<sup>4</sup> exist for new hydropower capacity in the United States:

1. **Optimization, i.e., rehabilitating, expanding, upgrading, and improving efficiency, of existing hydropower facilities;**
2. **Powering non-powered dams;**
3. **Installing hydropower in existing water conveyance infrastructure, such as conduits and canals;**
4. **Developing hydropower projects on new stream-reaches; and**
5. **Increasing pumped storage hydropower.**

Development of these potential resources will require sustainable<sup>5</sup> development and operations practices. Future hydropower must integrate environmental stewardship, economic performance, and availability of critical water resources for production of clean energy.

Chapter 2, *State of Hydropower in the United States*, summarizes the status of hydropower in the United States as of year-end 2015 within eight important topic areas: history, contributions, and context; role in the grid; markets and project development economics; opportunities for development; design, infrastructure, and technology; operations and maintenance; pumped storage; and economic impact.

These eight topic areas provide key contextual and technical information— including trends, opportunities and challenges—that was used in developing the *Hydropower Vision* and that is fundamental to the future concepts, growth potential, and roadmap actions explored in Chapters 1, 3, and 4.

- 
1. As of 2014.
  2. Hydropower as discussed in this report includes new or conventional technologies that use diverted or impounded water to create hydraulic head to power turbines, and PSH facilities in which stored water is released to generate electricity and then pumped back during periods of excess generation to replenish a reservoir.
  3. Throughout this report, the term “hydropower” generally encompasses all categories of hydropower. If a distinction needs to be made, the term “hydropower generation” distinguishes other types of projects from “pumped storage hydropower,” or “PSH.”
  4. This report does not address marine (wave, current, and tidal) and river hydrokinetic technologies, as marine and hydrokinetic technologies are defined by Congress as separate and distinct from hydropower (Energy Policy Act of 2005. Public Law No: 109-58. 42 U.S.C. § 931 (a) (2)(D) Hydropower and 42 U.S.C. § 931 (a)(2)(E)(i) Miscellaneous Projects. See <https://www.congress.gov/109/%20plaws/publ58/PLAW-109publ58.pdf%20> <https://www.congress.gov/109/ plaws/publ58/PLAW-109publ58.pdf>).
  5. In the *Hydropower Vision*, the term *sustainable hydropower* describes a hydropower project or interrelated projects that are sited, designed, constructed, and operated to balance social, environmental, and economic objectives at multiple geographic scales (e.g., national, regional, basin, site).



## 2.0 Introduction

### *History, Contributions, and Context of Hydropower*

The world's first hydropower plant began to generate electrical energy in 1882 in Appleton, Wisconsin. The boom years for construction of hydropower facilities—from 1940 to 1970—responded to a rapidly growing economy with intense electricity demands. Hydropower development has waned since the 1990s due to rebalancing of water use priorities, market conditions, deregulation in the electricity industry, and other factors. As a result, the existing fleet of facilities—owned and operated by federal, public, and private entities<sup>6</sup>—is aging. Many of these facilities, including their dams and reservoirs, have multiple purposes beyond water storage and hydropower generation, including recreation, flood management, navigation, irrigation, municipal and industrial water supply, fish and wildlife, and cooling water for thermal plants. Hydropower's effects on the environment<sup>7</sup> are recognized by facility owners and operators and, working with resource and regulatory agencies, they implement measures to avoid, minimize, or mitigate these effects. Balancing the needs of society in a manner that leads to more sustainable hydropower requires advanced planning that incorporates potential effects of climate change on water availability patterns and encompasses multi-stakeholder approaches.

### *Role of Hydropower in the Grid*

Hydropower is capable of the full range of services required by electricity transmission grid, including system regulation and supply/demand balance, voltage and frequency support, stability, and black start capability. In particular, hydropower's flexibility to rapidly ramp generation up and down in response to changes in the balance between electrical loads and generators facilitates integration of renewable variable generation, such as wind and solar energy, into the grid. The contribution of hydropower to

grid planning and operations is expected to increase through improved quantification and valuation of hydropower's flexibility. In addition, small hydropower (defined in the *Hydropower Vision* as 0.5 to <10 MW) has the potential to increase deployment of distributed generation resources. As variable generation increases in the foreseeable future, the use of hydropower's flexibility—accounting for multiple water use requirements—to reduce system operating cost is an important trend.

### *Markets and Project Economics*

Compensation for hydropower generation comes from two primary sources: power markets and environmental markets.<sup>8</sup> In power markets, value is derived from power production and from flexibility to provide a wide range of power market services. Increasing penetration of variable generation, however, is changing how hydropower is compensated. Ownership also plays a key role in determining access to revenue streams and the investment perspective underlying how hydropower is valued. The structure and operation of hydropower markets varies regionally across the nation; some power markets are organized day-ahead type markets, while others are bilateral, based on longer term agreements. Improved alignment of hydropower valuation across power and environmental markets could decrease market variability and uncertainty. Electricity markets in the United States are also influenced by the increasing role of Canadian hydropower.

### *Opportunities for Hydropower Development*

Opportunity exists to support growth of hydropower as an economically competitive source of low-carbon renewable energy. The challenge, however, is to incorporate environmental performance<sup>9</sup> and sustainability principles, while balancing public energy needs and water resources—especially in the context of multiple

6. Federal agencies operate about 49% of the total installed hydropower capacity, with about 10% of the total number of installations. Public ownership, such as public utility districts and rural cooperatives, comprise about 24% of total installed U.S. capacity and 27% of the total number of hydropower facilities. Private owners, including investor-owned utilities and independent power producers, control about 25% of total installed capacity and 63% of the total number of plants.

7. Hydropower facilities can affect flow regimes, water quality, sediment transport, habitat connectivity, fish passage, and other factors.

8. Environmental markets include renewables markets—such as Renewable Portfolio Standards—and emissions markets, such as those associated with trading of allowances for certain pollutants.

9. Environmental performance refers to hydropower's effects on ecosystem structures, processes, and functions.



objectives for water use. Toward this end, improved communication and collaboration during the hydropower development process could help expedite the process and achieve desired outcomes for all parties. In addition, basin-scale or multi-basin watershed approaches to hydropower development could benefit all stakeholders through improved collaboration and application of advanced technologies.

### ***Design, Infrastructure, and Technology***

Research and design of hydropower facilities enhances civil structures, turbines, electrical components, and governors. Instrumentation, control, and monitoring equipment are also advancing technologically. Cost and construction time for civil structures can be reduced through technology advancements that include modular and segmented design, precast systems, smart concrete technology, and rock-bolted underpinning systems. Advances in technologies for power trains, shaft turbines, oil-free operations, battery and other storage capabilities, as well as equipment manufacturing and project design, can also improve the economic viability of hydropower generation. In combination with minimum in-stream flow levels, environmental protection technologies—such as fish screens, upstream passage facilities, aerating turbines, fish-friendly turbines, and surface flow outlets—help avoid or minimize the environmental impacts of hydropower operations.

### ***Operations and Maintenance***

Hydropower operations and maintenance (O&M) is the suite of activities that bring particular generating units online, monitor and control water releases, safely shut down units, service the components of hydropower facilities in a reliable manner, and generally help ensure dam safety. Decision making processes for O&M at individual plants are closely linked to river system and power grid operational requirements so that impacts of O&M activities on system operations are coordinating and minimized. An increasingly important element of O&M is ensuring environmental compliance through facility enhancements, including modeling of hydrologic cycles, refined operating procedures, and system monitoring.

Refinement of O&M methods can support hydropower growth through development of best practices and fleet-wide benchmarking, and by incorporating environmental mitigation measures into operations scheduling and planning.

### ***Pumped Storage Hydropower***

Pumped storage hydropower (PSH) is a proven, reliable, and commercially available large-scale energy resource that provides 97% of the total utility-scale energy storage in the United States [2]. Many PSH plants were constructed to complement large baseload nuclear and coal power plants, thereby providing increased loads at night when pumping and peaking power during the day through generation. In helping balance grid operations, PSH plants reduce overall system generation costs and provide a number of ancillary and essential reliability services to the grid, including frequency regulation and voltage support. PSH plants are also supporting integration of variable generation into the grid, helping avoid or minimize stability issues due to over-generation. Advanced PSH technology, such as adjustable or variable speed units, provides additional capabilities beyond those of older units. There is significant resource potential for new PSH development in the United States, especially closed-loop PSH. Realizing this potential will require overcoming economic, market, and regulatory challenges, such as fully optimized day-ahead and real-time markets.

### ***Economics of Hydropower***

Hydropower is a demonstrated economic driver, supporting jobs from engineering and construction to O&M, offering other economic benefits, and providing electricity to help businesses compete globally. Construction and O&M for hydropower plants supports approximately 143,000 jobs<sup>10</sup> in the United States (2013 data). The median age for the hydropower workforce is higher than the national average, however, indicating a need to focus on educational and training programs for workers entering the industry. Beyond jobs, hydropower facilities can offer multiple benefits, such as recreational use, transportation, drinking water, flood management, and hydropower. Each of these uses can provide net economic benefits to the region surrounding a hydropower facility.

10. According to analyses presented in this report (Section 2.8).



## 2.1 Hydropower History, Contributions, and Context

Hydropower<sup>11</sup> helps meet the United States' basic need for electrical energy. Hydropower's generation flexibility helps stabilize the electrical grid by balancing energy from various sources, including variable renewable energy from wind and solar power systems. Hydropower has a long life cycle and a renewable<sup>12</sup> fuel source that does not produce hazardous wastes and emissions. U.S. based hydropower enhances national energy security, because its fuel supply (water) cannot be controlled by foreign governments or groups. Hydropower development and operations necessarily are conducted within a multi-purpose context where adverse environmental, social, and cultural effects must be avoided, minimized, or mitigated, because hydropower's water supplies are public resources protected by state and federal laws.

This section of the *Hydropower Vision* introduces the present state of hydropower in the United States by offering a brief history of hydropower, describing general characteristics, explaining environmental aspects, and providing foundational material for advancing sustainable hydropower. The overall objective of Section 2.1 is to provide context for subsequent sections of Chapter 2 that detail fundamental features of the state of U.S. hydropower in 2015 and offer a framework for the *Hydropower Vision* and its roadmap. Chapter 2 sections include: 2.2 *The Role of Hydropower in the Grid*, 2.3 *Markets and Project Economics*, 2.4 *Hydropower Development*, 2.5 *Design, Infrastructure, and Technology*; 2.6 *Operations and Maintenance*; 2.7 *Pumped Storage Hydropower*, and 2.8 *Economic Value of Hydropower*.

### 2.1.1 Historical Perspective

Hydropower has a long history in the United States. The technology was used in the 1700s and 1800s to convert the kinetic energy of flowing water to mechanical energy for industrial activities such as grinding grain into flour, sawing wood into lumber, and powering textile mills (Figure 2-1). Hydropower



Photo courtesy of the National Canal Museum, an affiliate of the Delaware & Lehigh National Heritage Corridor, Easton, Pa

**Figure 2-1.** Water wheel for generating hydropower (Union Mills, New Hope, PA)2004–2013

was the first source of *electrical* energy ever used in the United States, which became possible with the invention of the electric generator by Michael Faraday in 1831 and the hydro-turbine by James Francis in 1849. The world's first hydropower plant to generate electricity began operating in 1882 in Appleton, Wisconsin [3]. The first long-distance transmission of electricity from hydropower was in 1889, from the Sullivan Plant at Willamette Falls to streetlights in Portland, Oregon, 14 miles away. Along with wind and solar, hydropower can claim to be one of the first *renewable* energy technologies. Hydropower was fundamental to the electrification of America during the first three decades of the 1900s. By 1912, hydropower accounted for 30% of U.S. electrical generation, increasing to a high of 36% in 1932, dropping back to 29% in 1950 [4, 5]. In the 1930s and 1940s, hydropower development was critical to raising the nation out of the Great Depression and fostered industrial production during World War II supporting rapid expansion of the country's energy output (Figures 2-2 and 2-3).

11. As used here, hydropower means hydroelectricity. Hydropower technologies discussed in the *Hydropower Vision* include conventional technologies, where diverted or impounded water creates hydraulic head to power turbines, and pumped storage hydropower, where stored water is released to generate electricity in a similar way, but is then pumped back up to replenish the storage reservoir. Marine and river hydrokinetics, which convert the energy of waves and tides, and ocean currents and rivers, respectively, into electricity, are not included in this report.

12. For purposes of the *Hydropower Vision*, hydropower is renewable in the sense that water is replenished through the hydrologic cycle.



For example, between 1937 and 1944, the U.S. Bureau of Reclamation (Reclamation) more than quadrupled its hydroelectric capacity [6]. The early era also included development of multi-purpose projects to provide irrigation water and flood control, with hydropower often a secondary objective. Major hydropower dams constructed during this pivotal period in U.S. history include the Bonneville and Grand Coulee dams on the Columbia River, Hoover Dam on the Colorado River, and the majority of the Tennessee Valley Authority (TVA) system.

Installation of new hydropower capacity in the United States increased from the early 1900s through the 1950s, peaked in the 1960s, and then declined in the 2000s (Figure 2-3). Most PSH capacity was installed in the 1960s, 1970s, and 1980s to complement operation of large, baseload coal and nuclear power plants and to help balance the grid by providing peaking power during daytime generation and load during nighttime pumping. Construction of new

PSH facilities has declined since the 1990s (Figure 2-3). This decline in new construction resulted from a rebalancing of water use priorities, market conditions, and other factors [7]. While development subsided, environmental statutes instituted in the 1960s and 70s resulted in modifications to hydropower operations for environmental purposes at hundreds of hydropower plants in the 1980s and beyond. The statutes helped raise existing projects to new standards of environmental protection to maximize net public interests, because hydropower installation had altered natural river systems.

Hydropower generation in the United States increased 175% between 1950 and 1970, from 100 terawatt-hours (TWh) to 275 TWh (Figure 2-4). Since the 1970s, average total energy produced by hydropower plants has remained consistent, at around 275 TWh per year. The amount of net total United States electricity generation contributed by hydropower has decreased, from 30% in 1950 to 7% in 2013, as nuclear power, coal, natural gas, and other sources have been added to the nation's energy portfolio to meet increasing demand. In terms of generation, hydropower is the primary source of renewable energy in the United States, delivering 48% of total renewable electricity sector generation in 2015, and roughly 62% of total cumulative renewable generation over the past decade (2006-2015) [1].

## 2.1.2 General Characteristics of Hydropower

Hydropower involves the physical process of directing flowing water through turbines to generate electricity. The amount of power generated is a function of the head (difference in height between the upstream pool and tailwater) and flow (volume of water passing a location per unit of time). Water is conveyed from an upstream pool created by a dam, or from a diversion to a powerhouse containing one or more turbines (Figure 2-5). At the turbine, energy is transferred via the turbine runner or other rotating element to spin a shaft connected to an electric generator. Water, after passing the turbine runner, enters a draft tube or other out-flow structure into the tailwater. The electrical energy produced by the generator exits the powerhouse via a transformer, which "steps up" (increases) the voltage



Poster by Lloyd Hoff, courtesy of Bonneville Power Administration Library

**Figure 2-2.** World War II era poster promoting hydropower



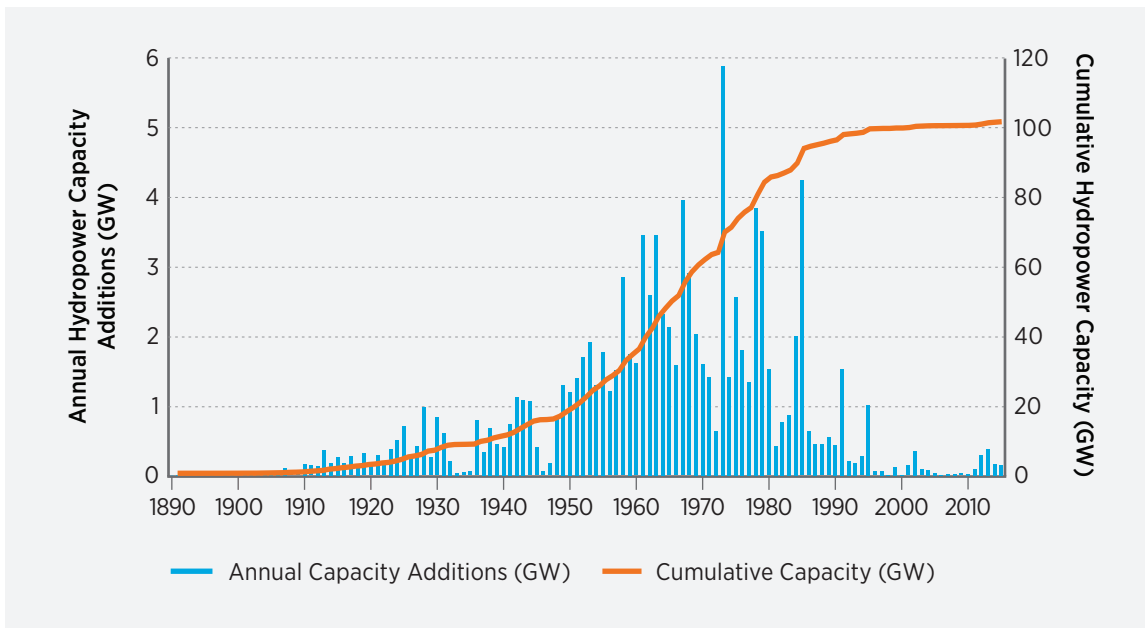

Sources: EIA Form 860 2011 [8], EIA Monthly Energy Review [4], FERC Energy Infrastructure Updates [9]

**Figure 2-3.** U.S. hydropower and pumped storage hydropower annual capacity additions and cumulative capacity from 1890-2015 (GW)

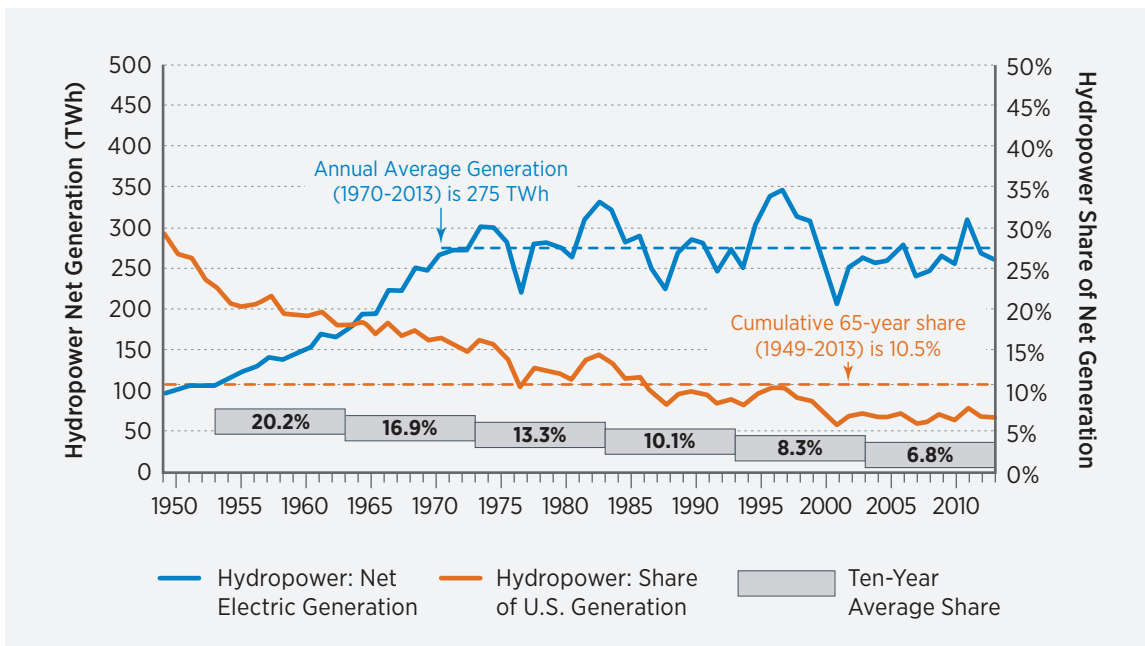

Sources: EIA Annual Energy Review [10] and EIA Electric Power Monthly [11]

**Figure 2-4.** Net hydropower generation and share of United States generation, 1950-2013



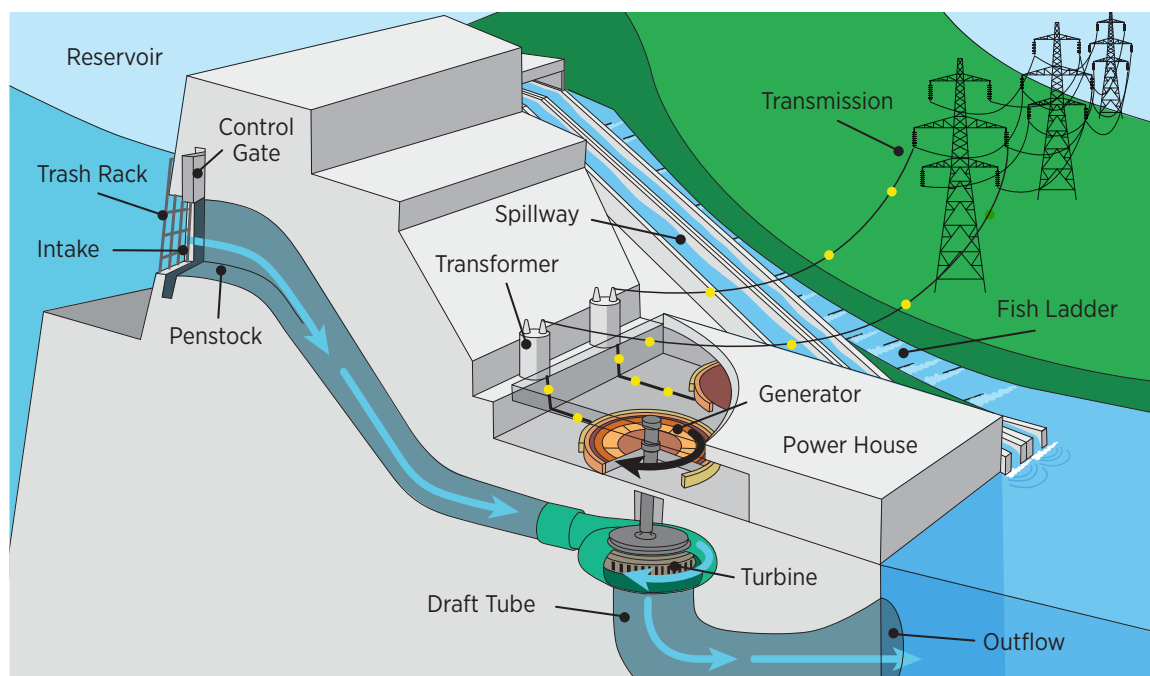

Source: U.S. Department of Energy [12]

**Figure 2-5.** Three-dimensional cross-section showing the components of a typical hydropower project (water flow is from left to right)

of the electricity flowing through transmission lines of the electrical grid. At substations and power poles, the voltage is “stepped down” (decreased) for delivery via distribution lines to end-use customers. For the *Hydropower Vision*, hydropower is classified based on capacity: micro (<0.5 megawatts [MW]), small (0.5 to <10 MW), medium (10 to <100 MW), large (100 to 500 MW), or very large (> 500 MW).

### Existing Hydropower Facilities

Forty-eight states have hydropower facilities, and ten of these states generated more than 10% of their electricity from hydropower in 2014 [13]. As of the end of 2014, the U.S. hydropower fleet contained 2,198 active power plants with a total capacity of 79.6 GW, and 42 PSH plants totaling 21.6 GW [2] (Figure 2-6).<sup>13</sup> There are three main classifications of hydropower facility ownership: federal, public, and private. There are also ownerships through public-private and public-federal partnerships. The three main federal agencies authorized by Congress to own and operate hydropower

plants are the U.S. Army Corps of Engineers (Corps), Reclamation, and the TVA. These agencies operate about 49% of the total installed hydropower capacity through ownership and operation of about 10% of the total number of hydropower facilities (Figure 2-7). Public ownership includes public utility districts, irrigation districts, states, and rural cooperatives, whose hydropower resources consist of about 24% of total installed U.S. capacity and 27% of the total number of hydropower facilities. Private owners, including investor-owned utilities, independent power producers, and industrial companies, control about 25% of total installed capacity and 63% of the total number of plants. These data include private owners of hydropower plants located at federal dams. For example, there are 90 privately owned power plants at Corps-owned dams [14] and 28 at Reclamation-owned dams [15].

13. Figure 2-6 includes an overlay of runoff distribution. The relationship of runoff to hydropower is discussed in more detail in the Multi-Purpose Dam Uses and Water Management section.



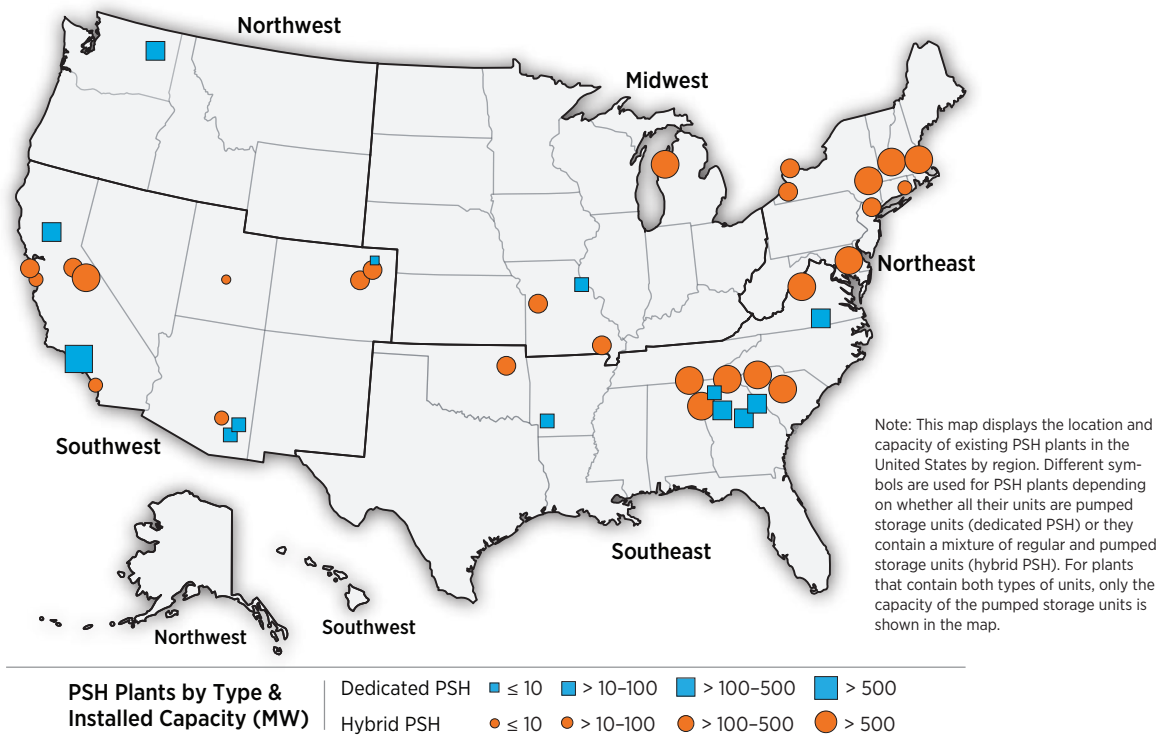
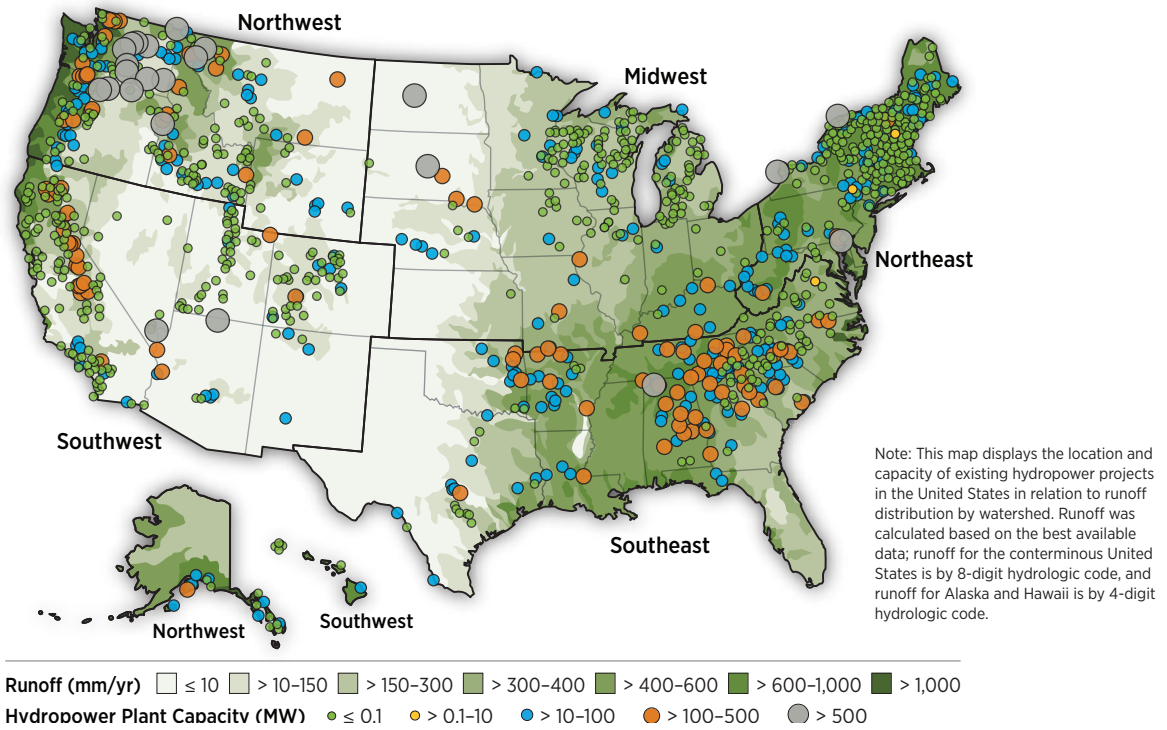

Source: Uriá-Martínez et al. 2015[2]

Figure 2-6. Map of facilities in the existing U.S. hydropower fleet: conventional hydropower (top) and PSH (bottom)

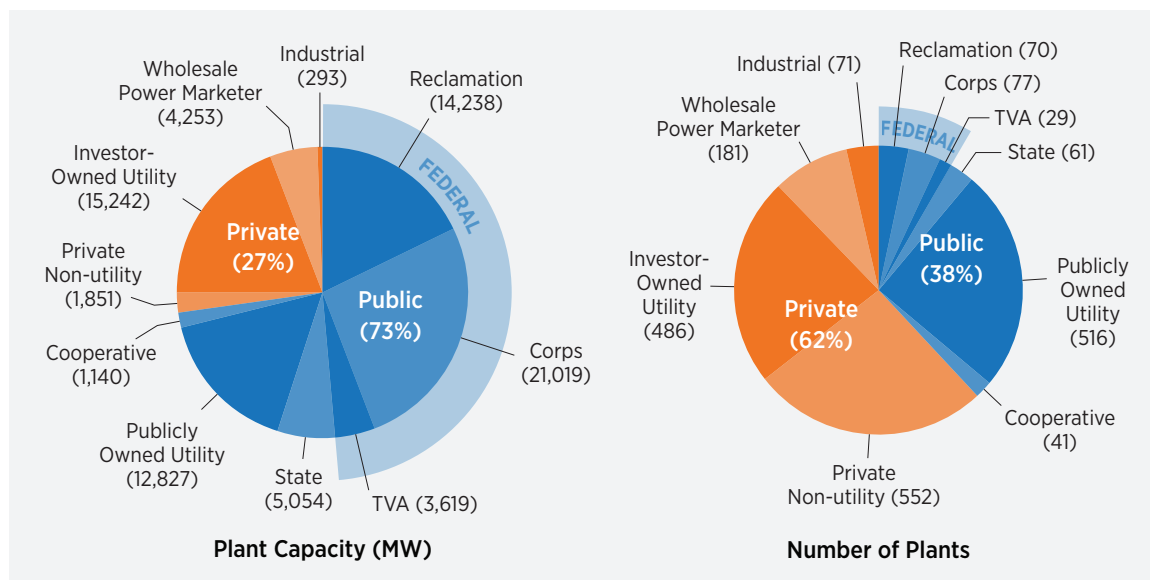

Note: The region delineation is based on Federal Energy Regulatory Commission hydropower regions.

Source: Uriá-Martínez et al. 2015[2]

**Figure 2-7.** U.S. hydropower plant ownership mix: capacity (left) and number of plants (right)

The states of California, Oregon, and Washington have the most installed hydropower capacity (~40 GW in 565 plants) of all areas of the country. Many of the region's hydropower facilities have capacities of more than 50 MW and are federally owned. In fact, hydropower plants in the Columbia River basin in the Pacific Northwest produce more than 40% of total U.S. hydropower generation. The Northeast region of the United States has the highest number of hydropower plants (~600), most of which are 0.1-10 MW. The Southwest region has low capacity (< 5 GW) and few plants (< 50 plants). In all regions, more plants are in the small size category (0.1-10 MW) than the other size categories. The generating facility with the highest capacity in the United States is the 6.9-GW Grand Coulee Dam on the Columbia River.

The existing United States fleet of hydropower plants is aging. For instance, as of 2014, the average age of Corps hydropower facilities was 49 years, and, as of 2015, the average age of Reclamation hydropower facilities was 58 years [7]. At the beginning of 2011, hydropower plants comprised 24 of the 25 oldest operating power facilities in the United States, with 72% of facilities older than 60 years. While the basic civil works of hydropower facilities are considered safe and reliable, the turbines, generators, and other mechanical and electrical equipment require

increased maintenance and refurbishing to maintain existing generation capacity. This often includes equipment upgrades, turbine efficiency improvements, and modifications that ensure environmental protection and mitigation. At existing plants where environmentally improved designs for new turbines were employed, e.g., new turbine runners at Wanapum Dam on the Columbia River, broad-scale upgrades and efficiency improvements have contributed to increasing hydropower capacity in the United States (see Section 2.5).

When costs to modernize or to meet environmental objectives outweigh the potential economic benefits of continued operation, hydropower facility owners may choose to decommission facilities. Examples include the Condit Dam in Washington and the Marmot Dam in Oregon. Other situations involve dam decommissioning where the primary purpose is to alleviate environmental impacts, e.g., Glines Canyon Dam and Elwha Dam, both in the state of Washington. Factors influencing decommissioning also include costs of replacement energy, changes in water availability, and public interests. Decommissioning has generally been limited to older (mean age 87 years), small capacity projects (0.4-10 MW) [16]. About 168 MW of hydropower were decommissioned during 2005-2013 [2].



In addition to the lower 48 contiguous U.S. states, existing hydropower contributes to electricity supplies in Hawaii and Alaska. As of 2015, there were 22 operational hydropower projects in Hawaii with a total installed capacity of nearly 40 MW [17]. In 2014, hydropower across the state generated 85,444 megawatt hours (MWh), which accounted for 0.9% of all electricity sold by Hawaii's electric utilities to their customers [18]. In Alaska, hydropower contributes 25% of the statewide electrical energy [11], with 47 existing hydroelectric projects and a combined capacity of 474 MW. Development of local, non-distributed hydropower is of interest in Hawaii and Alaska, and elsewhere in the United States.

### Operational Modes

In terms of operating modes (as defined by McManamay et al. 2016 [19]), the majority of hydropower facilities in the United States *by number of facilities* are peaking or canal/conduit (Figure 2-8), while the majority *by capacity* are peaking and

run-of-river (Figure 2-9). Peaking plants release water to produce energy when electricity demand is high (peaking), typically during weekday mornings and afternoons. If there is limited storage capacity, storage dams upstream, or both, run-of-river projects can also serve peaking purposes. These operating modes range in operating flexibility<sup>14</sup> from least flexible (canal/conduit) to most flexible (peaking).

Figure 2-10 illustrates the installed capacity for typical types of hydropower (as defined by Uría-Martínez et al. 2015 [2]), broken down by region.

### Multi-Purpose Dam Uses and Water Management

Dams and reservoirs have multiple purposes beyond storage and flow regulation for hydropower generation (Figure 2-11).<sup>15</sup> Since hydropower is a non-consumptive use of water, water flowing through a turbine can be used again for other purposes. For powered dams, recreation is the most common secondary purpose of reservoirs. Other purposes

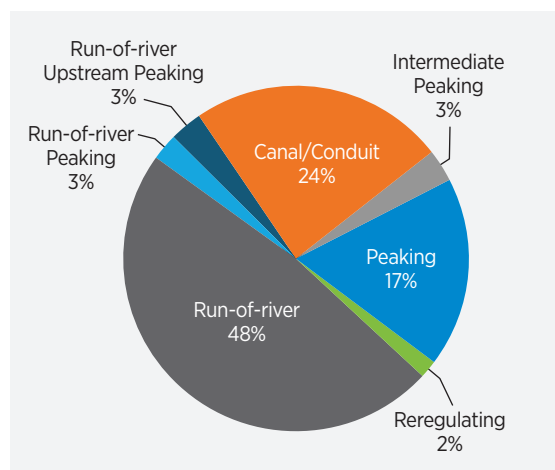

Source: NHAAP FY15 Plant Database [15]

**Figure 2-8.** Distribution of operating modes for hydropower facilities, by number of projects

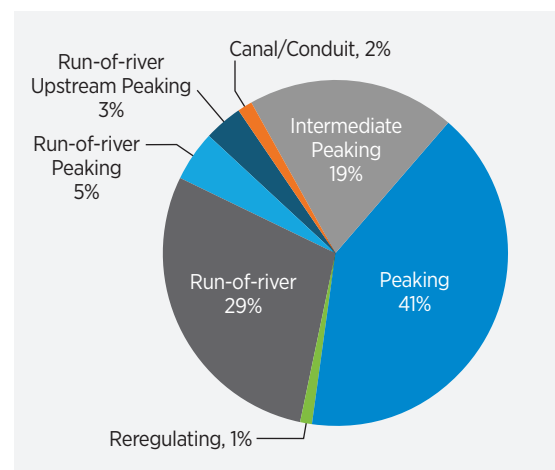

Source: NHAAP FY15 Plant Database [15]

**Figure 2-9.** Distribution of operating modes for hydropower facilities, by capacity

Note for Figures 2-8 and 2-9: The values are based on the most updated plant information available. Retired and pumped storage plants were removed from the analysis. Also not included are 813 plants for which the Mode of Operation field was "null". The data thus represent 65% of total number of plants and 78% of total capacity. Source: NHAAP FY15 Plant Database [15]

14. The "flexibility" of a hydropower plant is the capability to choose the optimal timing of power production, to provide reserves, and to respond quickly to changing market and power system needs. The extent to which a plant has flexibility is dependent upon plant technology and design characteristics, regulations governing operations, and the priority of power production and ancillary grid services provision amongst the other multiple water uses of a facility. Limitations on flexibility can include constraints on the maximum or minimum amount of water allowed to be discharged through a facility as well as the speed with which that rate of flow can be changed ("ramp rate"). Prescribed ramp rates are also a matter of safety for boaters and anglers.
15. Note that, in Figure 2-11, the use categories are not mutually exclusive; a given dam can be included in more than one category. The data include only powered dams that also have purposes other than hydropower generation.

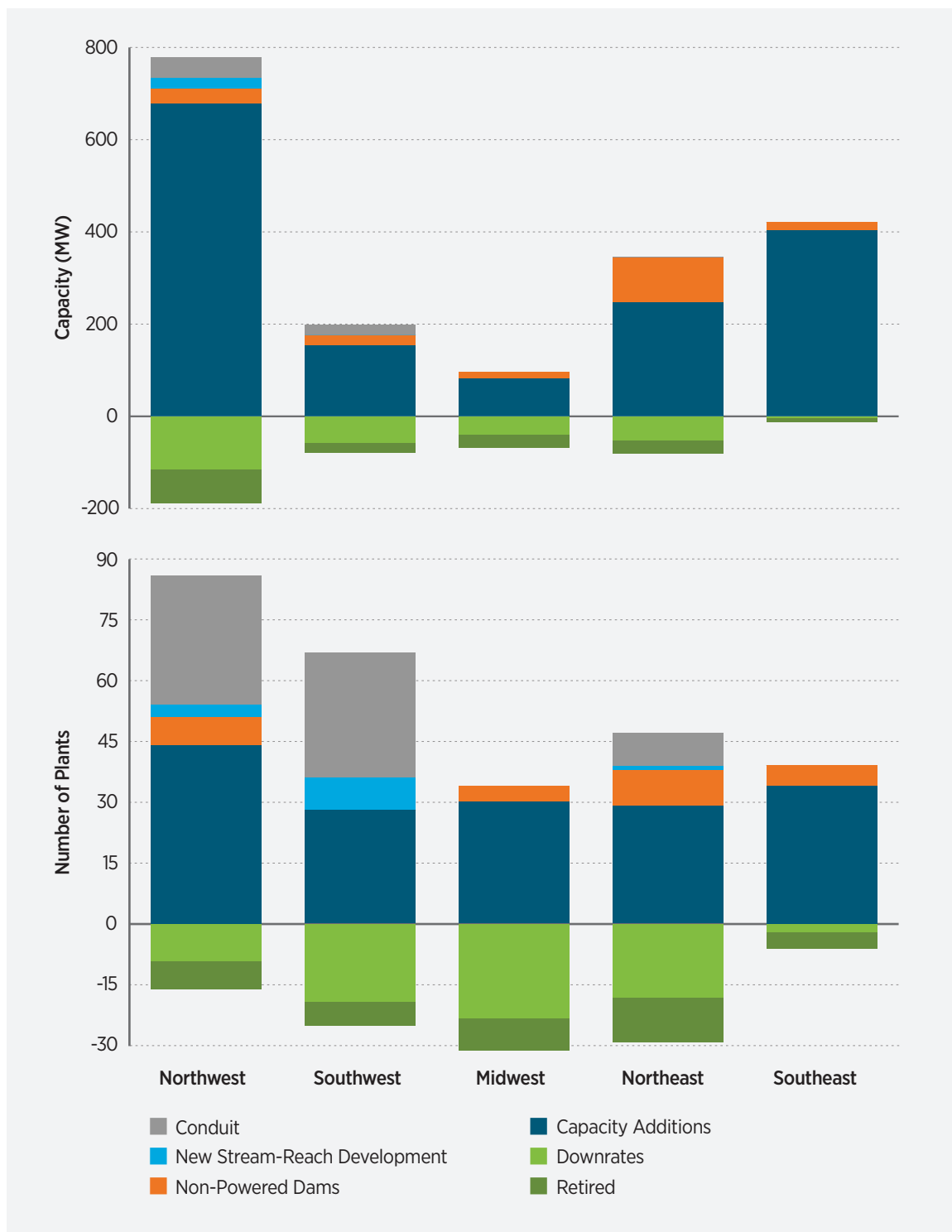

Source: Uriá-Martínez et al. 2015 [2]

**Figure 2-10** Comparison of regional differences in hydropower capacity by project type (2005-2013)



include fish and wildlife, flood management, navigation, agricultural irrigation, drinking water supply, and cooling water for thermal plants. Hydropower is the primary authorized purpose at only 2.5% of the approximately 87,359 federal dams across the country [20]. Many are not suited for hydropower because low head (<15 feet) or low flow limits potential energy production, or there are other limiting factors such as those related to environmental concerns, dam integrity/safety, proximity to load centers and transmission, and multiple use conflicts [21]. Prioritization of uses can be mandated in Federal Energy Regulatory Commission (FERC) licenses for non-federal projects and in Congressional authorizations for federal projects. The overarching intent is to operate the projects in a given basin(s) as a system, in an economically and environmentally responsible fashion.

General water management practices include monitoring and managing surface water runoff into streams, rivers, lakes, reservoirs, and other waterways. Hydropower generation is generally positively correlated with runoff in upstream watersheds [22]. Water management can employ forecasts of water supply (predictions of the volume of runoff over a given time period) and rate-of-flow (predictions of stream flows) using weather predictions (precipitation), accumulated snow measurements, and other information. Multiple agencies and entities have a role in making

and applying runoff and stream flow forecasts, including project owner/operators, power marketers, the National Weather Service, the U.S. Geological Survey, and the Natural Resources Conservation Service. Dependable forecasting allows water managers to optimize beneficial uses and minimize unnecessary costs. Water management planning for hydropower operations and other uses is complex and on-going.

Water availability is determined by hydrologic processes, which are affected by climate, geology, and landforms. Water availability varies temporally (seasonally and annually) and spatially (longitudinally and regionally). For example, runoff patterns in the eastern United States are determined primarily by rain, while snowpack drives runoff patterns throughout most of the West.

Water availability patterns are influenced by changes in climate, including those considered possible under global climate change models. Climate modeling generally suggests that dry regions are likely to get drier and wet regions wetter [23]. Hydropower managers can use predictions of future water supplies produced by climate models to prepare contingency plans for weather emergencies and disasters. Hydropower resources would be affected by runoff patterns that are changing due to variations in typical temperature and precipitation patterns, both spatially and temporally. These

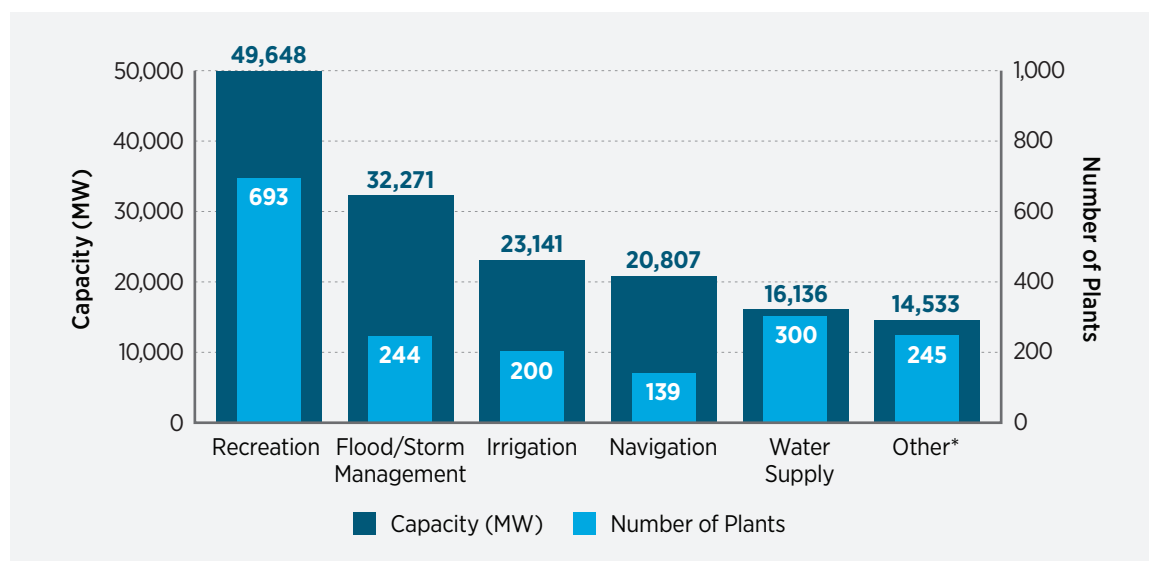

Note: The use categories are not mutually exclusive; a given dam can be included in more than one category. The data include only powered dams. Source: Uriá-Martínez et al. 2015 [2]

**Figure 2-11.** Total capacity and number of plants for six separate uses (illustrated by the blue bars) of existing hydropower dams and reservoirs

changes could affect water quality (e.g., temperature, dissolved oxygen), and stream flows, as well as timing and level of energy demand, seasonal pricing, and rates for electricity. In the Pacific region, for example, warmer air temperatures would cause increased evaporation and more precipitation to fall as rain than snow.

Water scheduling for hydropower generation takes into account runoff forecasts, energy markets, environmental objectives, and other factors. In some cases, long-term power contract commitments come into play during scheduling. On a temporal basis, scheduling is performed for short-term (minutes, hours, days) and long-term (weeks, months, years) horizons. On a spatial basis, scheduling occurs at scales ranging from a given turbine unit (turbine level or turbine scale), to a full hydropower facility (site level or site scale), to a given region with multiple watersheds (basin level or basin scale). Sophisticated computer models have been developed to aid hydropower schedulers. Sensor networks, data assimilations, visualization, and other elements are all part of decision support systems used in most river and power control centers. Text Box 2-1 provides an example of scheduling and planning for one complex hydropower system.

### **Transmission and Markets**

Hydropower transmission and markets involve interconnections and balancing authority areas, coordinating entities, wholesale markets, cost and pricing trends, and incentive programs.

### **Interconnections and Balancing Authority Areas.**

Three primary transmission grids, called “interconnections,” serve the United States: the Eastern Interconnection, the Western Interconnection, and the Electricity Reliability Council of Texas (ERCOT), which is also called the Texas Interconnection (Figure 2-12). A fourth major North American grid is the Quebec Interconnection. A given interconnection comprises segments called balancing authority areas (BAAs). Within a BAA, supply (generation) must be exactly matched to demand (load). If a BAA fails to have balanced generation and demand, it either forces excess generation onto adjacent BAAs, or more commonly, draws power from them. Balance may be achieved through imports and exports of power; however, these must be scheduled and coordinated between adjacent BAAs. Maintaining this balance within and across BAAs is critical for system reliability. If a BAA is significantly out of balance, even momentarily, and adjacent BAAs do not have sufficient flexible generation to respond, there may be a load interruption.

**Coordinating Entities.** Multiple entities oversee the flow of electricity from generation sources to consumers, each with specific responsibilities. Under Section 215 of the Federal Power Act, FERC certified the North American Electric Reliability Corporation (NERC), a not-for-profit membership corporation, to serve as the electric reliability organization responsible for developing and enforcing Reliability Standards for the electrical bulk-power system. These standards set

Text Box 2-1.

### **Real-Time Modeling of Hydropower System Operations Across Multiple Objectives**

The Federal Columbia River Power System comprises 31 hydropower facilities that are operated under a complex mixture of power and non-power objectives and constraints related to multi-purpose uses. Although the objectives and constraints are typically well understood, there is uncertainty in fundamental elements, such as stream flows, load obligations, intermittent generation resources, and balancing reserves. Therefore, it is important to accurately model Federal Columbia River Power System operations to manage uncertainty and optimize use of water. Federal

Columbia River Power System managers use modeling technologies to develop probabilistic views of capacity, power inventory, and operations as well as to support risk-based operational and marketing decisions. The models provide feasible, stable results and have robust solution algorithms, high resolution, and quick execution times. A range of operational possibilities are modelled to make risk-informed decisions for successful operations and marketing strategies to meet the multiple purposes of the Federal Columbia River Power System .





Source: Wall Street Journal/Google images

**Figure 2-12.** Transmission systems and three main grid interconnections in North America. In this map, the Quebec (Canada) Interconnection is part of the Eastern Interconnection.

mandatory requirements for generator owners and operators, transmission owners and operators, balancing authorities and other entities having a role in bulk-power system reliability. NERC's Reliability Standards have been adopted by the Canadian provinces, and also apply in the northern portion of Baja California in Mexico. NERC has delegated certain authorities to eight regional entities (Figure 2-13) that enforce compliance with agreed-upon standards and procedures. NERC's role is to provide oversight with regard to operation of the electrical bulk-power system.

A registered Balancing Authority (BA) is generally the entity responsible for ensuring balance and reliability within a given BAA. System operations within a BAA are conducted by BAs, such as Independent System Operators (ISOs) and Regional Transmission Organizations (RTOs), where they exist. In the absence of a registered BA, transmission owners, utilities and federal Power Marketing Administrations (PMAs) coordinate the dispatch of generation and transmission according to rules established by FERC in a manner consistent with procedures and responsibilities of entities within

the NERC region or sub-region. Failure to demonstrate load and generation resides within a BA can result in mandatory fines and sanctions from NERC. Failure to adequately perform BA functions when an entity is a registered BA will also result in mandatory fines and sanctions and could potentially result in losing BA registration in the NERC registry.

The various entities involved in electrical bulk-power can overlap. For example, the state of California has eight Balancing Authorities. Electricity service in the state is dominated by three large investor-owned utilities (IOUs) and two large municipal utilities. At one time, each was a BA. After the state deregulated investor-owned utility service, a state-wide ISO (CAISO) was established to manage the transmission assets of the three IOUs, thereby combining three Balancing Authorities into one. The state's other utilities were encouraged to join CAISO, but few agreed to do so. As a result, the two large municipal utilities are each a Balancing Authority, and collections of other, smaller utilities make up the remaining five BAs. Each Balancing Authority maintains system balance by

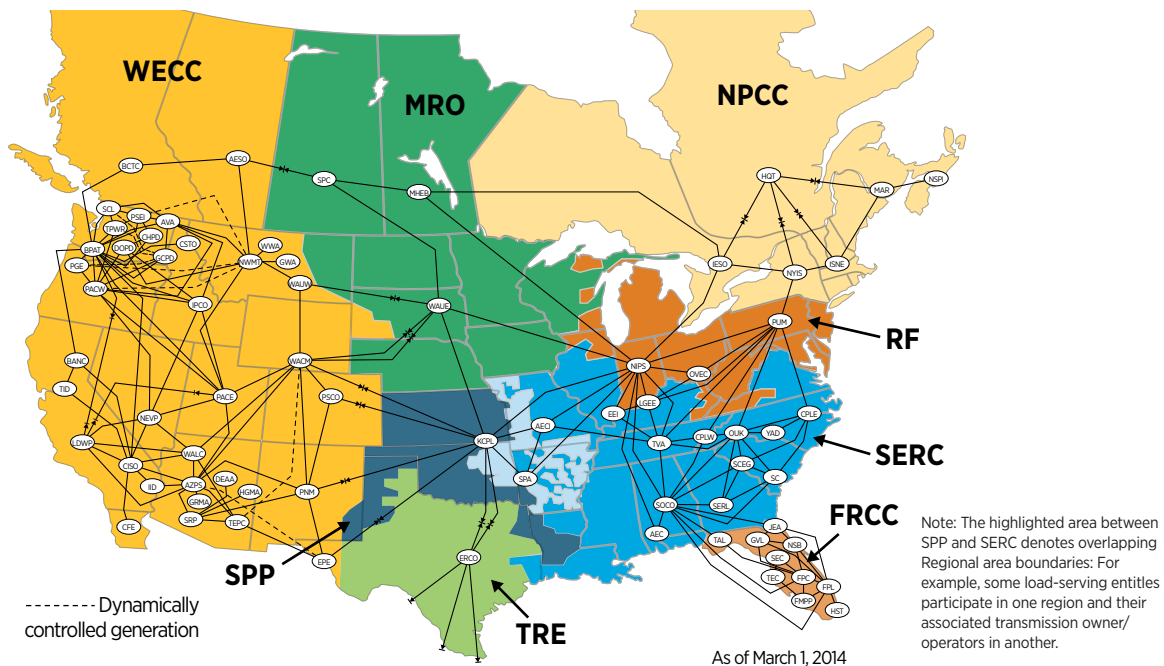

Note: FRCC = Florida Reliability Coordinating Council; MRO = Midwest Reliability Organization; NPCC = Northeast Power Coordinating Council; RF = Reliability First; SERC = SERC Reliability Corporation; SPP = Southwest Power Pool; TRE = Texas Reliability Entity; WECC = Western Electricity Coordinating Council

Source: NERC [25]

**Figure 2-13.** Map of coordinating entities organized under the North American Electric Reliability Corporation

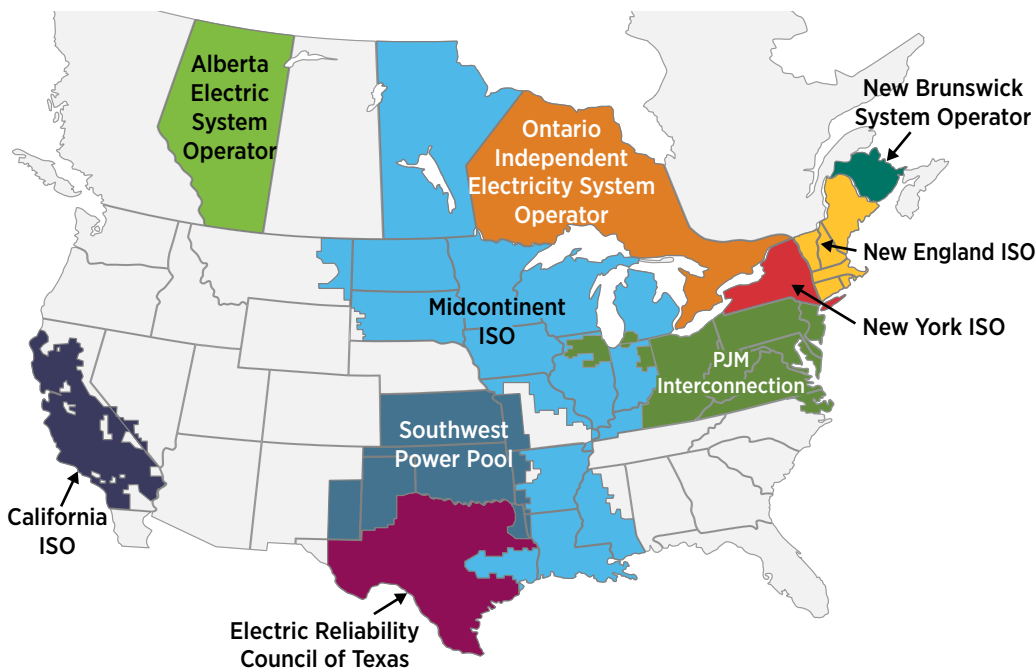

Source: Western Area Power Administration [26]

**Figure 2-14.** Map of North American Regional Transmission Organizations



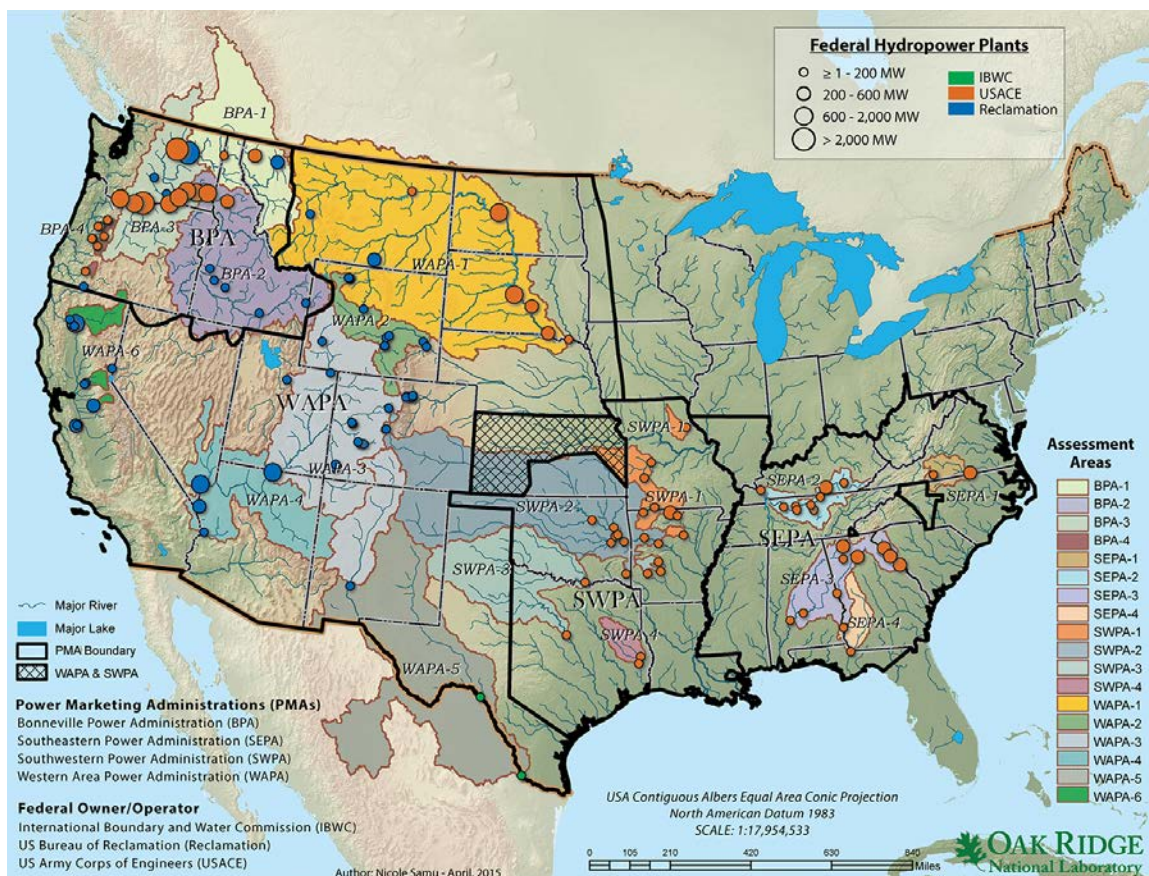

Source: NHAAP [27]

**Figure 2-15.** Map of federal Power Marketing Administration regions

controlling output levels of generation units, and by scheduling the import and export of electricity to and from neighboring BAAs. ISOs and RTOs (Figure 2-14) are formed upon approval by FERC and operate much of the nation's electrical bulk-power system. As noted, some regions of the United States do not have ISOs or RTOs. Transmission functions in those regions are performed by other entities, such as vertically integrated utilities or municipal utilities.

The federal PMAs transmit and market the electricity generated at federal hydropower projects owned and operated by the Corps or Reclamation (Figure 2-15). The four PMAs—Bonneville, Southeastern, Southwestern, and Western Area power administrations—are all part of the U.S. Department of Energy (DOE). The PMAs market hydropower at cost-based rates to “preference entities” such as public utility districts, but may also sell surplus energy to other utilities. PMAs

sell wholesale electricity to various BAs, ISOs, RTOs, and utilities. They also have BA responsibilities in many of their operating areas. Although PMAs operate across state and BAA boundaries, power deliveries to load-serving entities, such as a municipal utility, are often included as generation within each respective entities' BAA. In the California example above, power delivered by the Bonneville Power Administration (BPA) or the Western Area Power Administration to utility customers in California is managed by CAISO or the individual receiving utility as part of its BAA responsibility. While TVA is not a PMA, it is a corporate agency of the United States, transmitting and marketing electricity produced at TVA power plants.

**Linkages with Canada.** Canadian hydropower is linked with U.S. hydropower and the bulk-power system electricity grids in North America. More than 60% of Canadian power is generated by hydropower,

with a 2012 installed capacity of about 75 GW [24]. In 2012, net export of electricity from Canada to the United States was 47 TWh. In the eastern and central United States, energy supplies include hydropower from Ontario Hydro (7 GW capacity), Hydro-Quebec (35 GW capacity), and Manitoba Hydro (5 GW capacity). In the northwestern United States, a key factor in operation of the Federal Columbia River Power System is water storage at Canadian dams that were constructed as a result of the Columbia River Treaty between the United States and Canada. Three Canadian dams operated by BC Hydro—Mica, Hugh Keenleyside, and Duncan—provide almost half of the storage capacity in the Coordinated Columbia River System. These projects help control flooding; optimize energy generation; and provide water for environmental purposes, such as flows to aid downstream migration of juvenile salmon and steelhead.

**Wholesale Electricity Markets.** Wholesale electricity markets for hydropower vary in purpose, structure, and complexity. Markets also differ based on factors such as whether the hydropower is generated by a federal or non-federal entity, or whether it is transmitted and marketed in a region run by an ISO/RTO or

---

**In 2014, electricity prices in the Pacific Northwest were lowest in the nation (EIA 2015b), a region where low-cost hydropower is the predominant source of electricity.**

---

through bilateral arrangements, such as a long-term power sales contract between BPA and Alcoa, Inc., a direct service customer. Markets also exist for hydropower as renewable or low-carbon energy, the most common of which are found at the state level in the form of Renewable Energy Credits (RECs). Hydropower's eligibility to generate RECs varies by state [28].

**Cost and Pricing Trends.** Once construction and other upfront costs are accounted for, costs to produce hydropower are low because the “fuel” is essentially free and operations and maintenance (O&M) costs are relatively low. EIA [93] reported the fixed and variable O&M costs for hydropower at \$14.13/kilowatts (kW)-year<sup>16</sup> and \$0.00/kW-year, respectively.

16. One “kW-year” is 1 kW of generation over a 1-year period.

17. LIHI, a non-profit corporation, established a certification process for existing hydropower plants that have avoided or reduced their environmental impacts pursuant to LIHI criteria.

The next lowest fixed and variable O&M costs were for combined cycle natural gas at \$13.17/kw-yr. and \$3.60/MWh, respectively [29]. Total installed costs can range from \$500/kW to \$3,500/kW or more depending on plant size, civil structures, and electro-mechanical equipment [30]. Wholesale prices for hydropower vary by market, region (Figure 2-16), season, and other factors. In the West, where snowpack is a major determinant of water supply, electricity prices can fall as a result of increased hydropower generation during the spring snowmelt period [31].

**Incentive Programs.** Incentives can be a factor in project development decisions. This was demonstrated during the early years (1981–1986) of the Public Utility Regulatory Policies Act (Pub. L. 95-617) when projects could earn predictable revenues, which resulted in an increase in investment in new hydropower projects [33]. A variety of state-level renewable portfolio policies, federal production tax credits, federal incentive programs, and federal investment tax credits are intended to provide an incentive for hydropower development. Most states have Renewable Portfolio Standards (RPSs) (Figure 2-17). Of these, a subset includes hydropower in RPSs and other renewable programs [28] (Table 2-1). State RPS programs vary in terms of hydropower capacity limits, eligibility of new hydropower, and whether certification by the Low Impact Hydropower Institute (LIHI)<sup>17</sup> is required. In general, incentive programs are expected to affect the market for existing hydropower and financing for new development.

### **Regulatory Setting**

The regulatory environment for hydropower includes numerous laws at federal, state, and tribal levels. Regulations vary depending on whether a facility is federally or non-federally owned. Several key regulatory developments and trends influence hydropower and, consequently, the *Hydropower Vision*.

While many laws have affected hydropower operation and development (Table 2-2), two provide a basis for the modern regulatory setting: the Reclamation Act of 1902 (Pub. L. 57-161) and the Federal Water Power Act of 1920 (FPA) (41 Stat. 1353). The Reclamation Act authorized development of irrigation projects, including dams and reservoirs, in 17 western states. The FPA established federal regulation of hydropower

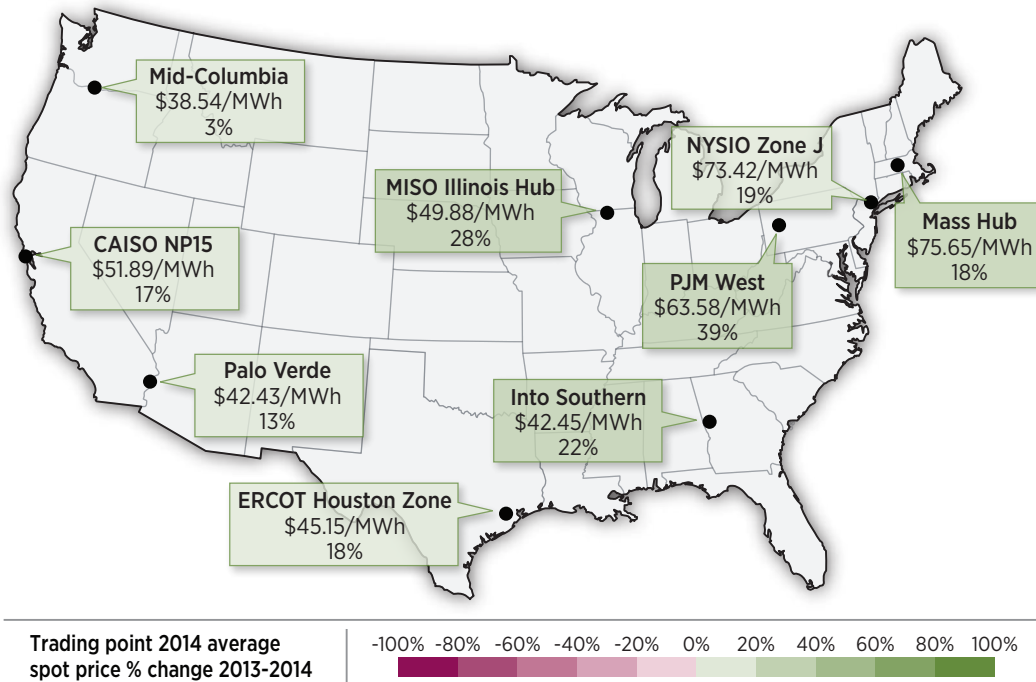

Source: EIA 2015 [32]

Figure 2-16. Average wholesale prices for 2014 electricity as of January 12, 2015

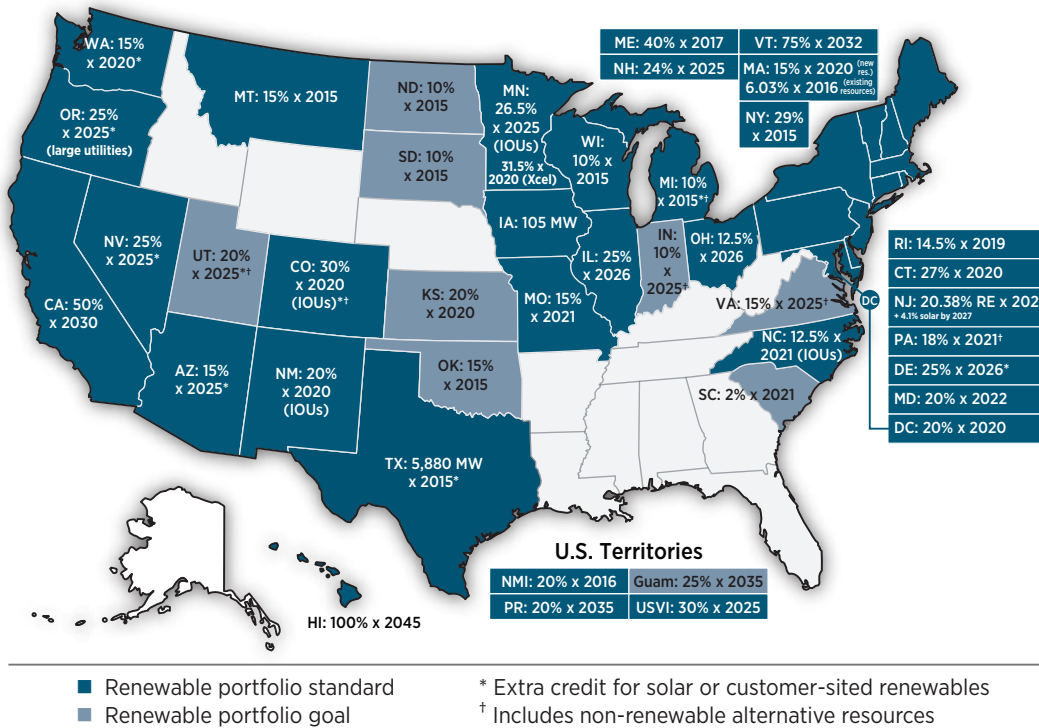

Source: Database of State Incentives for Renewables and Efficiency [34]

Figure 2-17. Renewable Portfolio Standard policies across the United States



development in the United States and provides FERC with the statutory basis for regulatory decisions related to hydropower. The early years of hydropower regulation focused on regulating projects for multiple uses, including navigation, flood control, and irrigation.

The Fish and Wildlife Coordination Act (16 U.S.C. § 661 et seq.), as amended in 1946 (60 Stat. 1080), required consideration of wildlife in federal actions. The Coordination Act was followed by several major environmental laws in the 1960s and 1970s. Additional laws that are most relevant to hydropower include the Wild and Scenic Rivers Act of 1968 (16 U.S.C. § 1271 et seq., Pub. L. 90-542), the National Environmental Policy Act (NEPA) of 1969 (42 U.S.C. § 4321 et seq., Pub. L. 91-190),

the Clean Water Act of 1972 (33 U.S.C. § 1251 et seq., Pub. L. 92-500), and the Endangered Species Act (ESA) of 1973 (16 U.S.C. § 1531 et seq., Pub. L. 93-205). In addition, several laws—especially the Electric Consumers Protection Act of 1986 (16 U.S.C. § 791a et seq., Pub. L. 99-495) and the Energy Policy Act of 2005 (42 U.S.C. § 15801 et seq., Pub. L. 109-58)—influenced the regulatory and permitting processes under which hydropower has been developed. Individual states have laws related to hydropower, addressing parameters such as fish passage, dam safety, and renewable energy incentives. Tribes and other parties also have significant regulatory roles pertaining to hydropower. Table 2-2 highlights some key laws relevant to non-federal and federal hydropower.

**Table 2-1.** Hydropower in State Renewable Portfolio Standards

State	Capacity Limit (MW)	New Hydropower Allowed?	Lihi Certification Required?
Arizona	10 MW (for new hydro)	Yes	No
California	30	Yes	No
Colorado	10 MW (Tier 1), 30 MW(Tier 2)	Yes	No
Connecticut	5 MW, online July 2003 or after (Tier 1), 5 MW, online before July 2003 (Tier 2)	Yes	No
Delaware	30	Yes	Yes
District of Columbia	none specified	Yes	No
Hawaii	none specified	Yes	No
Illinois	none specified	No	No
Iowa	"small" but no explicit limit	Yes	No
Kansas	10	Yes	No
Maine	100 MW, online September 2005 or after (Tier 1), 100 MW, online before September 2005 (Tier 2)	Yes	No
Maryland	30 MW, online January 2004 or after (Tier 1), no limitation if before January 2004 (Tier 2)	Yes, but no new dams	No
Massachusetts	30 MW, online after 2007 (Tier 1), 7.5 MW, online 2007 or before (Tier 2)	Yes	Yes

*Continued next page*

Table 2-1. continued

State	Capacity Limit (MW)	New Hydropower Allowed?	Lihi Certification Required?
Michigan	none specified	Yes, but no new impoundments	No
Minnesota	100	Yes	No
Missouri	10	Yes	No
Montana	10 MW (existing), 15 MW (if online after April 2009)	Yes, but on existing reservoirs or irrigation systems	No
Nevada	30	Yes, but no new diversions or dams	No
New Hampshire	5	No	No
New Jersey	3 MW, online after July 2012 (Class I), 30 MW (Class II)	Yes	No
New Mexico	None specified	Yes	No
New York	None specified	Yes	No
North Carolina	10 MW (primary schedule), no limitations (secondary schedule)	Yes	No
Ohio	None specified	Yes	No
Oregon	None specified	Yes, but must be located in "protected areas"	Yes
Pennsylvania	50	Yes	Yes
Rhode Island	30	Yes	No
Texas	10 MW for small hydro, 150MW for repowered hydro	Yes	No
Washington	None specified	Yes, but no new diversions or impoundments	No
Wisconsin	None specified	Yes	No

Notes: 1) There may be additional limitations on hydropower eligibility beyond those described above. 2) State rules vary on whether PSH facilities qualify under the hydropower provision. 3) This table does not describe eligible capacity or efficiency gains at hydropower facilities.

Source: Stori 2013 [28]

**Table 2-2.** Chronological List of Some Key Laws Relevant to Hydropower

Year	Legislation	Description
1899	Rivers and Harbors Appropriation Act	Required that dams proposed for navigable streams obtain approval from Congress, the Chief of Engineers (Corps), and the Secretary of the Army prior to construction.
1902	Reclamation Act	Funded irrigation projects for the arid lands of 17 states in the U.S. West and established the Reclamation Service (later to become the Bureau of Reclamation).
1920	Federal Water Power Act	Established the Federal Power Commission (FPC) to centralize the planning and regulation of hydropower within one agency and coordinate hydropower projects. Provided for hydropower projects on federal tribal reservations, development of waterways, and consideration of additional interests such as fish and wildlife.
1933	TVA Act	Created the TVA to provide economic development, flood control, navigation, and electricity generation in the Tennessee Valley.
1935	Federal Power Act (FPA)	Originally the Federal Water Power Act of 1935. Extended FPC's authority to all hydroelectric projects built by utilities engaged in interstate commerce. Amended numerous times.
1935	Public Utility Holding Company Act (PUHCA)	Facilitated regulation of electric utilities.
1936	Flood Control Act	Authorized the Corps and other federal agencies to build flood control projects such as dams, levees, and dikes. One of numerous flood control acts.
1939	Reclamation Project Act	Extended to 40 years the contract term for hydropower sales or lease of power privileges, with preference to public utilities.
1977	Department of Energy Organization	Abolished the FPC and created FERC to implement the license approval process.
1978	Public Utility Regulatory Policies Act	Promoted energy conservation, greater use of domestic energy, and waste/cogeneration/renewable energy sources, including hydropower development at small existing dams.
1986	Electric Consumers Protection Act	Amended the FPA to require equal consideration of fish and wildlife habitat, and generally increased the importance of environmental considerations in FERC licensing processes.
2005	Energy Policy Act	Provided tax incentives and loan guarantees for various types of energy, repealed PUHCA, and provided more opportunity for parties to challenge the underlying facts resource agencies use to base any mandatory conditions submitted to FERC.
2013	Bureau of Reclamation Small Conduit Hydropower Development and Rural Jobs Act	Authorized small conduit hydropower development (<5 MW) at Reclamation-owned facilities and streamlined the regulatory process for this development through the Lease of Power Privilege process. The legislation has the potential to affect hydropower development at a minimum of 373 sites, as identified in the Reclamation's conduit resource assessment [63].
2013	Hydropower Regulatory Efficiency Act	Directed FERC to explore possible 2-year licensing process for powering existing non-powered dams and closed-loop PSH projects; increased the FERC small hydro exemption from 5 to 10 MW; excluded certain conduit projects <5 MW from FERC jurisdiction; and increased FERC exemption for conduit projects to 40 MW, among other provisions. Included a directive that DOE assess PSH opportunities, as well as hydropower potential using existing conduit infrastructure.

Note: Key environmental laws applicable to hydropower are referenced elsewhere in the text.



As previously noted, regulation of hydropower has two broad categories depending on ownership—non-federal and federal. Non-federal covers the development and regulation of hydropower by public and private utilities, independent power producers, and power marketers. As the main regulatory body for non-federal hydropower, FERC is responsible for licensing new projects, relicensing existing projects, and providing environmental and safety oversight for more than 2,500 non-federal hydropower dams. During licensing and relicensing processes, FERC is required to give equal consideration to multiple factors when issuing a license. As stated in section 4(e) of the FPA, “The Commission, in addition to the power and development purposes for which licenses are issued, shall give equal consideration to the purposes of energy conservation, the protection, mitigation of damage to, and enhancement of, fish and wildlife...the protection of recreational opportunities, and the preservation of other aspects of environmental quality.”

Development of federal hydropower projects requires authorization and appropriation from Congress. For example, Corps hydropower development is authorized through Water Resources and Development Acts. Reclamation’s Lease of Power Privilege process is applied to develop hydropower at Reclamation dams and canals. To guide operation of hydropower facilities, the Corps, TVA, and Reclamation adhere to specific requirements in applicable Congressional authorizations, which can include natural resource protection and conservation; respond to interactions with various state agencies, tribes, and other stakeholders; and comply with applicable federal laws (e.g., NEPA and ESA). Federal hydropower operators must produce a NEPA Environmental Assessment/Environmental Impact Statement to change operations or modify facilities, and a subsequent Record of Decision.

The hydropower regulation process involves numerous stakeholders and participants. Environmental laws require that federal and state agencies be involved in the hydropower regulatory process. Indian tribes also have an important role, as do non-governmental organizations representing a variety of interests such as industry, the environment, fishing, and recreation. Tribes and non-governmental organizations can influence the outcome of hydropower regulatory processes. Participants in regulatory processes, for example, may help develop mitigation actions for non-federal and federal projects.

### 2.1.3 Environmental Aspects

As with other types of energy development, construction and operation of dams can cause serious environmental impacts. During the early 20th century, national priorities were not focused on environmental issues. By the latter half of the 20th century, however, there was increased understanding of the impacts of dams on ecosystems and greater interest in environmental concerns. As a consequence, the federal laws discussed in Section 2.1.2 require mitigation measures to address environmental effects on natural resources related to operation of existing and proposed dams and hydropower facilities. Some of the important laws are NEPA, Clean Water Act, and ESA.

Dam construction affects riverine ecosystems, from the physical characteristics of the river and its floodplain to the composition and viability of biota and ecosystem function. For instance, dams can alter channel geomorphology [35], connectivity of habitat [36], sediment supply [37], water quality [38], flow regimes [39], nutrient transfer [40], and fish habitat, health, and survival [41]. Regulations to address environmental impacts at the project level are in force. Regulatory provisions addressing the adverse effects of dams should help, for example, to recover ESA-listed species. Planning at the “whole system” level or “basin scale” is relevant both in the siting of new hydropower facilities and in considering whether existing facilities that are obsolete or uneconomical can be removed and replaced with new hydropower capacity. Moreover, cumulative impact and strategic environmental assessments can provide a broad scoping of environmental impacts. Some potential environmental concerns associated with dam construction (with or without hydropower) and with operation of hydropower facilities are described here, along with potential methods to avoid or mitigate them.

**Flow Regimes.** Dam operations can alter the fundamental hydrologic properties of rivers, such as the magnitude, frequency, duration, timing, and rate of change of river flows. This alteration of natural runoff patterns has ecological significance, because healthy riverine ecosystems have natural dynamics of flows to form and maintain habitats and species (e.g., Poff et al. 1997 [42]). For example, storage dams can hold back water when it naturally would be flowing downstream as runoff, creating unnatural decreased flows. This stored water can be released at a later time for hydropower generation during typically low flow periods,

creating unnatural increased flows. This can be beneficial during droughts when stored water releases can help maintain riverine habitats. One approach to mitigate for altered flow regimes can be for hydropower facility operators to target specific hydrologic attributes, e.g., maintaining flows above seasonally adjusted minimums. In addition, variations in daily hydropower operations, such as ramping rates or timing of releases, is used in attempts to provide improved flow regimes for sensitive species or critical stages in species life cycles. Maintaining habitat availability and conserving habitats that function effectively over a range of flows (termed persistent habitat) is another way to protect affected species [43].

**Water Quality.** Construction and operation of dams can affect water quality in impoundments and downstream rivers in a variety of ways. Direct effects include spatial and temporal changes in water temperature, dissolved oxygen, nutrients, turbidity, dissolved gases, and more. Indirect effects include the responses of riverine organisms, populations, and communities to these changes in water quality. Measures to address concerns about water quality and toxins include tools that can assess and predict concerns, allowing hydropower operators to avoid or mitigate these effects. One example is an auto-venting turbine developed to increase the concentration of dissolved oxygen in water exiting hydropower plants, especially plants in the southeastern United States where low dissolved oxygen levels can exist due to deep withdrawals of low-oxygen water from the forebay or decaying organic matter and warm water temperatures [44].

**Sediment Transport.** Dams alter the sediment transport process by decreasing sediment loads. This in turn affects water turbidity and bank erosion rates, as well as channel formation, aggregation/degradation, complexity, and maintenance. These changes to natural sediment transport in a river influence habitat-forming processes, such as bars and shoals [39]. In general, sedimentation is increased in the dam's reservoir due to relatively slow water velocity. In contrast, sedimentation downstream of a dam is decreased due to lower sediment load and relatively high water velocities. Additional detrimental downstream effects may include channel constriction and substrate coarsening. One approach that has been pursued to address the effects of decreased

sediment transport on riverine habitat formation has been to attempt to physically build up sediment in sediment-starved areas downstream of hydropower dams [45]. In addition, a sediment sluiceway might be designed into a dam to pass impounded sediments during high flow periods [46].

#### **Barriers to Movement and Loss of Connectivity.**

Dams impede the movement of organisms, nutrients, and energy in a river network and reduce or block connectivity between habitats upstream and downstream of the structure [47]. This is an important concern for fish species whose life cycle requires migration between freshwater and marine environments, and for resident fish species whose life stages involve movements among different riverine habitats. Lack of connectivity also inhibits natural gene transfer among populations of resident fish [48]. Methods to improve fish passage and connectivity include construction of collection facilities or passage structures, such as surface flow outlets and fish ladders, to help facilitate downstream and upstream movement of fish past a dam. Basin-scale planning during the siting phase can also help avoid or minimize the effects of barriers (e.g., Larson et al. 2014 [49]; McNanamay et al. 2015 [50]).

**Dam Passage Injury and Mortality to Fishes.** Downstream passage through a turbine, spillway, or other route can injure or kill fish [51, 52, 53]. Impacts can be direct (e.g., strike by a turbine blade) or indirect (e.g., predation while disoriented post-passage). Dams can also affect upstream fish passage by causing migration delays and increasing vulnerability to predation by concentrating fish at entrance to upstream passage facilities. In rivers with multiple dams, impacts may be cumulative from one dam to the next, depending on species behavior. One area of research on this topic is the evaluation of accelerated deployment of new or refurbished hydropower turbines employing "fish-friendly" turbine designs [54], such as minimum gap<sup>18</sup> runners [55]. Other approaches include installing passage structures or devices to bypass downstream-moving fish around turbines [56] and intake screens to prevent entrainment of fish [57].

Addressing environmental impacts has become a critical part of the hydropower development or relicensing process. Some of the most common strategies to avoid or mitigate environmental impacts are minimum streamflow requirements, dissolved oxygen

18. According to Hogan et al. (2014) [55], the minimum gap runner is, "a modification of a Kaplan turbine in which the gaps between the adjustable runner blade and the hub, and between the blade tip and the discharge ring, are minimized at all blade positions."

**Balancing the needs of society and the environment in a way that creates environmentally sustainable hydropower of the future requires advanced planning, technical, and legal approaches. For a given basin, new and innovative approaches to achieve balanced hydropower development can be pursued within an adaptive management\* framework instituted by and with active participation of stakeholders (e.g., Irwin and Freeman 2002 [58]). Importantly, systematic sharing of case studies emerging from application of new approaches may facilitate “learning by doing” and increase the rate of adaptation and innovation.**

\*Adaptive management involves a systematic, rigorous approach for learning through experiences and results from management actions [59].

abatement, fish passage structures, improved operations, recreation enhancements, and ecosystem restoration. Dam removal can also be used as a mitigation strategy in a “trade-off” or optimization situation at the basin scale, where environmental, economic, and social values are treated as co-equal objectives during new hydropower development. An example is the Penobscot River basin, where stakeholders reached an agreement to add hydropower in some areas and remove dams in others [60]. Successfully avoiding or mitigating environmental impacts is essential to hydropower of the 21st century.

## 2.1.4 Advancing Sustainable Hydropower

Growing hydropower in general will require refurbishing the existing fleet, adding new hydropower capacity, and balancing multiple water use objectives. Sustainability is essential to this growth, because hydropower of the 21st century will need to integrate principles of environmental stewardship and water use management that balance societal needs for energy with

protection of the environment. Potential resources for additional capacity have been identified, and some are under development as of 2015. Principles and practices of sustainable hydropower provide a foundation for hydropower development. They also set a context for actions in the *Hydropower Vision* roadmap, which will need to include sustainability considerations to ensure balanced hydropower development.

### Resource Potential

Five main potential resources exist for new or added hydropower capacity,<sup>19</sup> including PSH, in the United States:

- 1. Refurbishment**—rehabilitating, expanding, upgrading, and improving efficiency and capacity of existing hydropower facilities. Also termed modernizing or maintaining, this avenue is being pursued in response to an aging fleet of hydropower facilities as well as other factors. Hydropower capacity that might be added through refurbishment is about 7 GW (based on information from USBR 2011 [61], USACE 2009 [62]).
- 2. Non-Powered Dams**—powering non-powered dams (NPDs). This avenue contains the greatest opportunity for adding hydropower capacity on a per-dam basis (not including PSH). NPDs have the potential to add about 12 GW of new capacity [19].
- 3. Conduits and Canals**—installing hydropower in existing water conveyance infrastructure, such as canals and conduits. Many of the potential projects would be considered small (< 10 MW) or micro hydropower (< 0.5 MW). The resource potential for Reclamation-owned canals is about 104 MW [63]. Beyond this, there have been no nationwide resource assessments for conduits and canals [64].
- 4. New Sites**—developing new hydropower projects. These new stream-reach development (NSD) projects would be new projects on previously undeveloped sections of waterways. Excluding only areas protected by federal legislation that limits the development of new hydropower, the hydropower capacity that might be added from NSDs is about 66 GW [65].<sup>20</sup>

19. The capacity values in this section represent technical potential capacity, which is not necessarily the same as the amount of hydropower that can be sustainably or feasibly developed. See Chapter 3, Table O3-3, for discussion of how these technical resource potential estimates are used to inform the modeled resource potential of the *Hydropower Vision* analysis.

20. Kao et al. [65] noted, “These potential high-energy-density areas should be regarded as worthy of more detailed site-by-site evaluation by engineering and environmental professionals; not all areas identified in this assessment will be practical or feasible to develop for various reasons.” See Chapter 3, Table O3-3, for discussion of how these technical resource potential estimates are used to inform the modeled resource potential of the *Hydropower Vision* analysis.



### 5. Pumped Storage Hydropower—increasing PSH.

Developers are pursuing new PSH resources, in the 200–2000 MW range per plant, as well as technology upgrades at existing PSH plants. As of February 2015, about 50 PSH projects had been proposed, representing about 40 GW of new capacity [66].

#### *Principles and Practices for Sustainable Hydropower*

A sustainable water and energy future is one in which the entire water-energy system, with its multiple components—economic, social, and ecological—can be made to function in the present as well as into the years ahead. Hydropower facilities need to be resilient to changes in system state (e.g., changing climate and hydrologic regimes), as well as responsive to scientific discoveries and new technologies that improve the potential for meeting long-range system factors.

**For purposes of the *Hydropower Vision*, sustainable hydropower is a project or interrelated projects that are sited, designed, constructed, and operated to balance social, environmental, and economic objectives at multiple geographic scales (e.g., national, regional, basin, site).**

Hydropower is closely linked to the multiple uses and values of the water-energy system in which it operates. The future of hydropower, therefore, is linked to the future of various, sometimes competing uses of both water and energy. Sustainable hydropower fits into the water-energy system by ensuring the ability to meet energy needs without jeopardizing the function of other components or the overall system. Where hydropower can be added to new and existing infrastructure in a way that satisfies environmental and economic objectives, it can enhance the societal value and long-term viability of that infrastructure. To be considered sustainable, the use of America’s hydropower resources for low-carbon energy production and the long-term economic viability of individual projects must be integrated with other water uses, stakeholders, and priorities.

Sustainability is often evaluated based on a project’s performance with respect to a set of objectives that reflect the interplay among economic, environmental,

**Table 2-3.** Examples of Sustainability Objectives Related to Hydropower<sup>21</sup>

Environmental objectives include:
• Avoiding risk to sensitive and high value freshwater and coastal systems
• Mitigating loss of riverine connectivity
• Maximizing persistence of native species and communities
• Supporting natural flow, sediment, and water quality regimes as appropriate
• Mitigating dissolved oxygen concerns
• Maintaining geomorphic equilibrium
Social objectives include:
• Ensuring public health and safety
• Ensuring provision of water supply for local communities
• Honoring tribal treaty rights
• Supporting cultural heritages and archeological resources
• Providing reservoir and downstream recreation opportunities
• Respecting land owner rights
Economic objectives include:
• Providing low-cost, reliable energy
• Minimizing development and operating costs
• Maximizing market/economic values
• Providing generation flexibility and long-term viability
• Providing job opportunities

21. Based in part on IHA [67] and Sale et al. [68]



**Figure 2-18.** Factors to be balanced in developing and growing sustainable hydropower

hydropower development and operation [67, 68] (Table 2-3 and Figure 2-18). While the *Hydropower Vision* is not intended to provide a new set of objectives for hydropower sustainability, this report offers a representative list of examples of economic, environmental, and social objectives that provides a broad-scale context of sustainable hydropower. It is not possible to “maximize” all of these objectives simultaneously, so sustainability focuses on taking individual values into account and optimizing across them. Figure 2-18 illustrates consideration for multiple factors.

## 2.1.5 Unique Value of Dams and Hydropower

As explained in this section, hydropower operates within a distinctive set of conditions, market structures, and environmental contexts. The distinctive values of hydropower to the nation’s energy supply create momentum for refurbishment of existing facilities and development of new facilities, i.e., renewed vigor of the industry in a sustainable manner that balances societal, environmental, and economic objectives. These unique values are summarized in this section, starting with the multiple purpose context in which hydropower operates.

Dams provide benefits to the public beyond low-cost, renewable hydropower. Dams protect public safety and economic well-being from flooding of downstream communities and lands; in fact, the primary authorized purpose for many dams is flood management, not hydropower. Storage dams improve resiliency in water supplies for downstream interests

during drought conditions. Dam reservoirs enable recreational opportunities for people to canoe, fish, water ski, camp, bird watch, and more. Agriculture in many western states relies on irrigation water from reservoirs. Dams divert water to municipal water facilities to be treated for people to consume. Water is a public resource that is used for many purposes, one of which is hydropower.

Hydropower has a long life cycle and provides critical generation and ancillary grid services to help ensure the reliability of the national electrical bulk-power system, including energy for base load and for load following (energy balancing) as system demands fluctuate. Additional services include frequency regulation, reactive supply and voltage control, spinning and non-spinning operating reserves, replacement services, black start capability, and firm capacity for system planning (see Text Box 2-2a and Text Box 2-2b for more information on these services). Quantifying and monetizing these ancillary and essential reliability services appropriately will help support the long-term viability of hydropower.

Hydropower’s value may also be monetized in renewables markets (compliance and voluntary markets) and emissions markets (federal clean air and greenhouse gas markets). Hydropower’s eligibility and treatment in these markets, however, varies widely across the United States. Increased market demand for renewable energy and an enhanced understanding of hydropower as a renewable energy resource could particularly motivate hydropower growth.

---

**Planning for 21st-century hydropower will likely include scenarios for climate change. In particular, owners of existing hydropower operations and developers of new hydropower facilities need to consider the projected effects of runoff patterns altered by climate change. To address this challenge, planning scenarios for hydropower operations may incorporate climate change predictions. In the future, utilities are also likely to establish processes to deal with climate change in long-term planning. For example, water storage has a role in mitigating adverse effects of global warming. While there remains much uncertainty about climate change and its effects on water resources, many inhibitive risks to future hydropower might be addressed using an adaptive management approach.**

---

The public economic value of hydropower is underscored by the number of skilled jobs that the industry supports. Positions to support hydropower include mechanics, electricians, operators, transmission line workers, dispatchers, schedulers, engineers, analysts, and marketing specialists. Growth of hydropower projects is expected to increase the number of jobs in the sector.

Hydropower has national security value as part of the nation's critical infrastructure and as a domestic contributor to energy supply. A robust, modernized fleet of hydropower facilities will help ensure maintenance of critical infrastructure including storage reservoirs for water supply and flood management, dams for power production, and a reliable electrical transmission grid.

Maintaining the capacity of the existing fleet of hydropower facilities and multi-purpose dams can help ensure public safety as well as availability of hydropower to support the electrical grid and serve the diverse energy mix that will be needed in the future. In order to serve the public's best interests, future hydropower development and generation must be balanced with environmental stewardship and multi-purpose water use management. The opportunities for growth in hydropower capacity and PSH flexibility must consider and attempt to optimize economic, environmental, and social parameters, which can vary by hydropower resource type, location, and regulatory environment.

Considering the future of hydropower requires understanding the long history and complex structure of the United States hydropower industry. The objectives of hydropower have not always been pursued within a context that balances outcomes with environmental and social objectives. More than 100 years of hydropower evolution, however, provide a solid foundation for a future hydropower industry that offers long-term viability by integrating environmental stewardship, economic performance, and availability of critical water resources for production of clean energy.

## 2.2 The Role of Hydropower in the Grid

---

Hydropower is a valuable generation resource within the U.S. electrical bulk-power system, including being linked to all three of the transmission interconnections comprising the system. In addition to providing cost-competitive, low-carbon electricity, hydropower's flexibility further supports the power system by contributing such services as system balance, voltage

support, and stability. This section examines how hydropower fits into the national electric generation and transmission system; the role it plays in grid operations and planning; and the opportunities and challenges for hydropower to have an increased grid presence in the decades to come.



### Highlights:

- Hydropower is a cost-competitive and low-carbon energy source that provides the full range of services required by the electrical bulk-power system, or grid.
- Hydropower is a flexible energy resource, but the limits of its flexibility are not widely understood and vary from plant to plant and region to region.
- The flexibility of hydropower generation can support integration of other variable renewables such as wind and solar energy. The value of hydropower to the integration of wind and solar will depend in part on the limits of its flexibility, as well as competition from other flexible resources.

## 2.2.1 Transmission System Overview

Large transmission grids can be operated as a single system or, as is more common, can be broken into several smaller transmission “balancing authority areas.” In these BAAs, reliability requirements are met while balancing load with generation and interchanges with neighboring regions. When a balancing area is well connected to neighboring areas, balancing the electrical system is typically easier because the transmission system permits the exchange of power and other services.<sup>22</sup> This requires transmission interconnection between areas that have available transfer capacity. For instance, hydropower facilities in the Pacific Northwest sell energy to utilities in California and the Southwest to help those regions meet their summer peak demand. This exchange is facilitated by market mechanisms that enable purchases and sales, or frequent economic dispatch (the process of changing generation output to meet changing conditions). The U.S. markets perform economic dispatch every five minutes [69].

The high-voltage transmission network in the United States is divided into three interconnections. The first two are the Western and Eastern Interconnections, located generally west and east of a line running north-south along the eastern Wyoming border (see Figure 2-12). The third interconnection is located in Texas, although it does not conform precisely to the state boundaries. Although each of these three regions is synchronized internally, they are not synchronized with each other. This means that there is limited ability to move power between these three synchronous regions using transmission interconnection ties (which convert and transmit power, in an AC-DC-AC<sup>23</sup> pattern), each of which has a capacity ranging from 100 MW to 200 MW. Total generating capacity in the United States exceeds 1,000 GW, and therefore the ability to transfer power among interconnections is quite small relative to the size of the system [70].

The objective of power system planners and operators is to provide a reliable supply of electrical energy at the lowest possible cost. Because demand fluctuates over all time scales, from seconds to decades, the mix of resources has evolved such that different types of resources provide specific types of services and energy to the power system. Traditionally, baseload generators (often coal or nuclear) have the lowest variable cost, and provide energy at all times with limited changes in output levels and subject to their availability. Mid-merit (intermediate) generation sources, which may consist of higher-variable cost natural gas<sup>24</sup> combined cycle or low-variable cost hydropower resources, operate based on their capabilities and the relative need of the system; these plants often provide high output during the day and lower (or even zero) power levels at night. Peaking power plants typically operate for limited periods of extremely high demand; such plants may consist of combustion turbines or PSH. PSH has traditionally been operated by pumping water at night when costs and prices are low, then releasing the water during the day when costs and prices are higher. This provides a form of arbitrage that can provide both economic and reliability benefits.

22. Such services consist of the various balancing and reliability functions necessary to keep the grid in a stable operating mode. These services are discussed in more detail in Text Box 2-2a.

23. Alternating current–direct current–alternating current.

24. When coal prices exceed gas prices, gas generation tends to be used more as baseload power, and coal as intermediate power, subject to physical constraints.

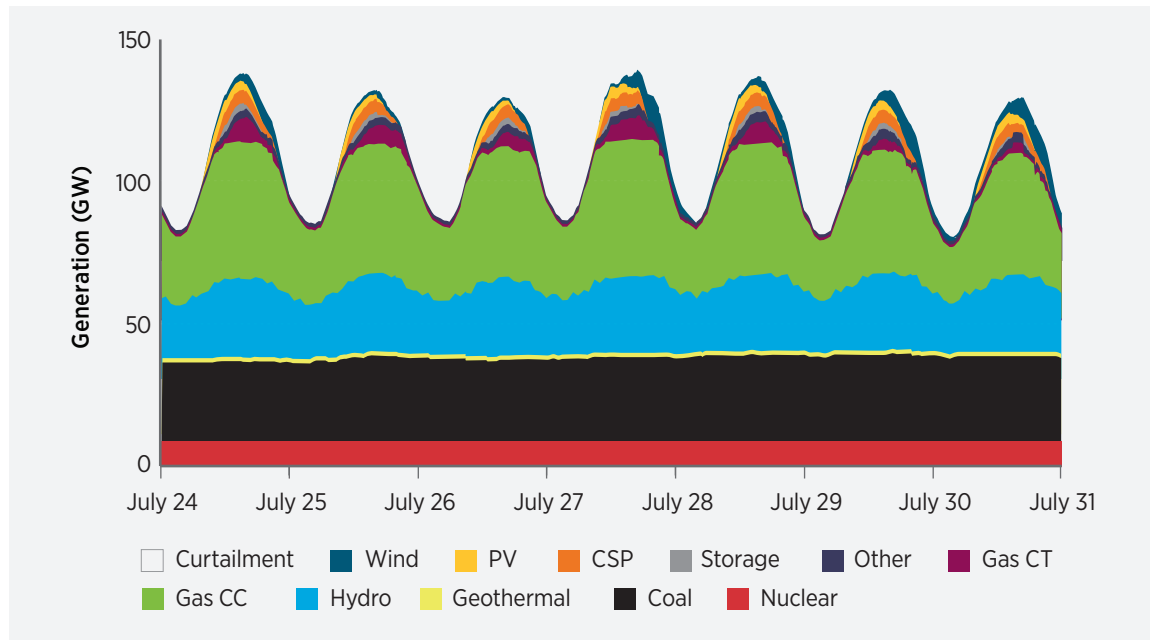

Source: Lew et al. 2013 [71]

**Figure 2-19.** Example of simulated power system dispatch for a week in the Western Interconnection

Although it is often used as intermediate generation, some hydropower operates as baseload generation. Wind and solar energy do not easily fit into these categories of generation. Because their variable cost is near zero, it is always economic to use as much wind/solar energy as possible, subject to various operating constraints. Figure 2-19 illustrates a typical week in the Western Interconnection with the use of hydropower generation to help meet peak demand during the day.

Most river basins offer at least some opportunity for water storage, typically as impoundment. This storage can be used to plan the timing of water release through the turbines—and thus the hydropower generation—to some degree. This timing depends on the size and other characteristics of the storage relative to the overall river system, as well as on the number of storage facilities within a given river basin. The amount of storage present in a river system as compared to the annual runoff greatly increases the flexibility and dispatchability of its associated hydropower.

## 2.2.2 Grid Services from Hydropower

To maintain system balance and stability, several elements of the power system must be managed so that the primary product—electrical energy—can be delivered safely, reliably, and economically. Doing so requires support from ancillary grid services, which FERC defines as: “those services necessary to support the transmission of electric power from seller to purchaser given the obligations of control areas and transmitting utilities within those control areas to maintain reliable operations of the interconnected transmission system” [72]. FERC defines six overall ancillary services,<sup>25</sup> many of which are now provided via markets in areas where RTOs or ISOs operate the grid. There are also some grid services that are necessary, but are not explicitly defined as ancillary services by FERC. Collectively, these services contribute primarily to maintenance of system balance on time scales ranging from sub-second to many minutes or even hours.

25. FERC defines the following ancillary services: (1) Scheduling, System Control and Dispatch Service, (2) Reactive Supply and Voltage Control from Generation Sources Service, (3) Regulation and Frequency Response Service, (4) Energy Imbalance Service, (5) Operating Reserve – Spinning Reserve Service, (6) Operating Reserve – Supplemental Reserve Service. See <http://www.ferc.gov/legal/maj-ord-reg/land-docs/order888.asp>. Other grid services may not fall under FERC’s definition. In this report, we refer to the overall collection of services as “grid services,” and indicate designated ancillary and essential reliability services where appropriate.

Text Box 2-2a.

## Grid Ancillary Services Relevant to Hydropower

**Regulation and frequency response:** *The ability of a resource or a system to respond to changes in system frequency, which must be maintained close to a constant level (60 Hertz).* NERC establishes control performance standards to ensure that each control area maintains reliability. This response can be provided by generators through three mechanisms:

- Inertia: A passive response, typically due to rotating masses in generators
- Primary frequency response or governor control: An active, unmanned response implemented through an electronic, digital, or mechanical device
- Frequency regulation: An active response to adjust an area's generation from a central location in order to maintain the area's interchange schedule and frequency

Hydropower generators can provide these regulation services. While hydropower turbines are able to respond to sudden changes in system frequency, the relatively large mass rotating in hydropower turbine generators and the dynamics of the water column in the penstock mean hydropower may have a lower response time than do gas or steam [75]. This larger inertia can, however, be an advantage in smaller or islanded power systems as it contributes to system stability [76].

**Load-following and flexibility reserve:** *The ability of the power system to balance variability existing in the load over longer timeframes than regulation and frequency response, from multiple minutes to several hours.* This function is typically accomplished by mid-merit (intermediate) and peaker units. Most U.S. hydropower units are able to and do effectively provide load following to an hourly schedule, as well as following ramps that occur within the hour time scale. This flexibility is not without impact, however. Increased variation in hydropower generation can impact riverbank erosion and aquatic life, as well as increase operating

costs and decrease system lifetime. In order to determine optimal use of hydropower for load-following services, these impacts must be considered against the cost of providing load following from other types of generation.

**Energy imbalance service:** *The transmission operator provides energy to cover any mismatch in hourly energy between the transmission customer's energy supply and the demand that is served in the balancing authority area.*

**Spinning reserve:** *Online (connected to the grid) generation that is reserved to quickly respond to system events (such as the loss of a generator) by increasing or decreasing output.* Except when already running at full load, hydropower offers an excellent source of reserve because it has high ramping capability throughout its range.

**Supplemental (non-spinning) reserve:** *Offline generation that is capable of being connected within a specified period (usually 10 minutes) in response to an event in the system.* Offline hydropower generation is capable of synchronizing quickly, and can provide non-spinning reserve to the extent that sufficient water supply is available to the unit for generation.

**Reactive power and voltage support:** *The portion of electricity that establishes and sustains the electric and magnetic fields of AC equipment.* Insufficient provision of reactive power can lead to voltage collapses and system instability. All hydropower facilities are operated to follow a voltage schedule to ensure sufficient voltage support. Reactive power is typically a local issue. Because hydropower facilities are often located in remote areas, their ability to provide reactive power in such locations can be essential.

**Black start (restoration) service:** *The capability to start up in the absence of support from the transmission grid.* This capability is of value to restart sections of the grid after a blackout and can typically be provided by hydropower.



The provision of these services has economic value above and beyond the value of the energy produced while generating, and increases the flexibility of the electrical system to accommodate load changes. Text Box 2-2a describes a number of grid services typically required by the grid [72, 73, 74] and that can be and are provided by hydropower. Certain key grid services are considered by NERC to be critical to maintaining the operations and stability of the national grid, and have been designated by them to be essential reliability services (Textbox 2-2b).

In theory, grid services can come from any resource that is physically capable of performing as needed to provide the service or services—i.e., a power plant, demand response, or storage device. In practice, some resource types may be constrained physically or economically from providing certain services. The result is that not all power plants provide all services, but it is also unnecessary to have these services from all plants. For example, large nuclear units do not generally supply regulation or other forms of reserve because it is expensive and time-consuming to change plant output and control the fuel supply to the reactors. Large coal units may provide regulation through automatic generation control, but may not

Text Box 2-2b.

### **Essential Reliability Services: Grid Services Designated As Critical to National Power System Reliability**

In its role as the Electric Reliability Organization of the United States, NERC has designated the services of frequency response, ramping, and voltage support as essential to reliable operation of the national power grid.

In December 2015, NERC issued its “Essential Reliability Services Task Force Measures Framework Report,” [79] to help stakeholders and policymakers understand and prepare for a changing energy resource mix. Subsequently, NERC issued a public statement [103] emphasizing key points regarding essential reliability services:

- *North America’s resource mix is undergoing a significant transformation at an accelerated pace with ongoing retirements of fossil-fired and nuclear capacity and growth in natural gas, wind, and solar resources.*
- *A key priority for our energy future is to ensure that reliability is maintained as the generation resource mix changes.*
- *NERC has identified three essential reliability services (ERS) that warrant attention—frequency response, ramping, and voltage*

*support. While these three services are among the first to manifest, we see other issues such as inertia beginning to emerge.*

- *For this reason, policy makers need to include provisions for essential reliability services of the grid: ramping, frequency control, voltage control, and also to address emerging issues, such as inertia.*
- *ERS are necessary to balance and maintain the North American BPS [bulk-power system]. Conventional generation (steam, hydro, and combustion turbine technologies) inherently provides ERS needed to reliably operate the system.*
- *It is necessary for policy makers to recognize the need for these services by ensuring that interconnection requirements, market mechanisms, or other reliability requirements provide sufficient means of adapting the system to accommodate large amounts of variable and/or distributed energy resources (DERs). Policy makers are increasingly recognizing these needs, which will become more significant as larger penetrations of renewables and retirements of base load coal (and some nuclear) occur.*

be as flexible or accurate as natural gas combined cycle plants. Inertial response will differ between large and small units because of differences in their rotating mass. There might also be instances in which the capability is available but not provided, e.g., units that have disabled governor control (e.g., Eto et al. 2010 [77] and Ela et al. 2014 [78]).

Because of the wide range of operational flexibility offered by most hydropower resources, hydropower is often used to provide various types of reserves and has demonstrated suitability for services that involve changing output on relatively short time scales (seconds to hours). There may be institutional constraints that result from market design and/or operating practice that prevent access to some of this latent flexibility; however, hydropower provides most, if not all, grid services. For example, Key [80] demonstrated that all grid services are provided by hydropower in varying degrees across the United States. This includes capacity and energy as well as designated ancillary services (e.g., regulation, spinning and non-spinning reserve, and voltage support). Hydropower is generally capable of providing frequency response and inertia. Not all resources may be needed to provide the electricity and balancing/support services needed by the grid, but many types of power plants with differing characteristics can operate as a system to provide all necessary services.

### 2.2.3 Hydropower and Electrical System Flexibility

Hydropower is a flexible system generation resource, but its generation is subject to many competing objectives and varying priorities—such as water deliveries, navigation, and others—that have an impact on minimum/maximum flows and minimum/maximum ramp rates. These constraints arise due to the numerous functions served by multi-purpose dams, as well as the environmental and regulatory constraints that govern hydropower facility operation. While these constraints vary from region to region and in differing hydrologic environments, environmental considerations include protections for fish and wildlife, water temperature, water quality and supply, and shoreline protection. Regulatory considerations that may

impact generation include flood management; navigation; recreation; land rights; hydraulic coordination between upstream and downstream dams; and any applicable federal, state, or local policies. The level of flexibility after these considerations are accounted for varies considerably, as illustrated in Text Box 2-3.

Despite the fact that hydropower operations are constrained in some respects, there is flexibility available for use in scheduling generators, for buying/selling energy, and for providing ancillary services. The availability of these services may vary by time of day, month, or year. Hydropower operators must consider how to quantify and use system flexibility; the value of this flexibility in the interconnected grid and market or utility systems; and how to best integrate physical infrastructure, governing bodies, and regulations to maximize utility and benefits of hydropower while meeting priorities and complying with regulations.

Hydropower's operational flexibility can be constrained by other functions of the facility or by regulatory issues. It can also sometimes be limited by the lack of available transmission capabilities to other regions or other constraints on the power system that do not allow the full provision of available services from hydropower. These constraints are unique to each hydropower system. For many electrical systems that include hydropower, considerations include how much flexibility is available from the hydropower and whether any further flexibility can be accessed through reasonable changes in operation, infrastructure development, or organization/regulation. For example, during periods of high water runoff during the spring when demand is low and wind energy is high, hydropower may contribute to over-generation because there is insufficient storage relative to run-of-river. The potential value of the flexibility services is not straightforward, in part because some aspects of flexibility are not properly valued by electricity/ancillary service markets (Section 2.3.1.2). The value is also likely to fluctuate as the electricity generation mix evolves.

Text Box 2-3.

### Flexibility and Free-Running Streams

Free-running streams downstream of hydro-power dams limit flexibility because rapid discharge decreases can cause undesirably large increases in water flow in a small amount of time. Smaller dams (called re-regulation or “rereg” dams) can be built just downstream of a larger dam. By impounding all or part of the water released, these smaller dams can often relieve issues such as stranding fish and imperiling people on the river banks. The

effects on flexibility can be substantial. For example, the Hungry Horse and Yellowtail projects, located in separate river basins in Montana, have characteristics similar to hydropower dams, but they discharge into a free-running stream and a rereg dam (Yellowtail Afterbay), respectively. The degree of flexibility, which is reflected as generation, is illustrated by these two dams’ respective generation patterns.



Hungry Horse dam (left), Yellowtail dam (center), and Yellowtail Afterbay dam (right) Photo credits: U.S. Bureau of Reclamation

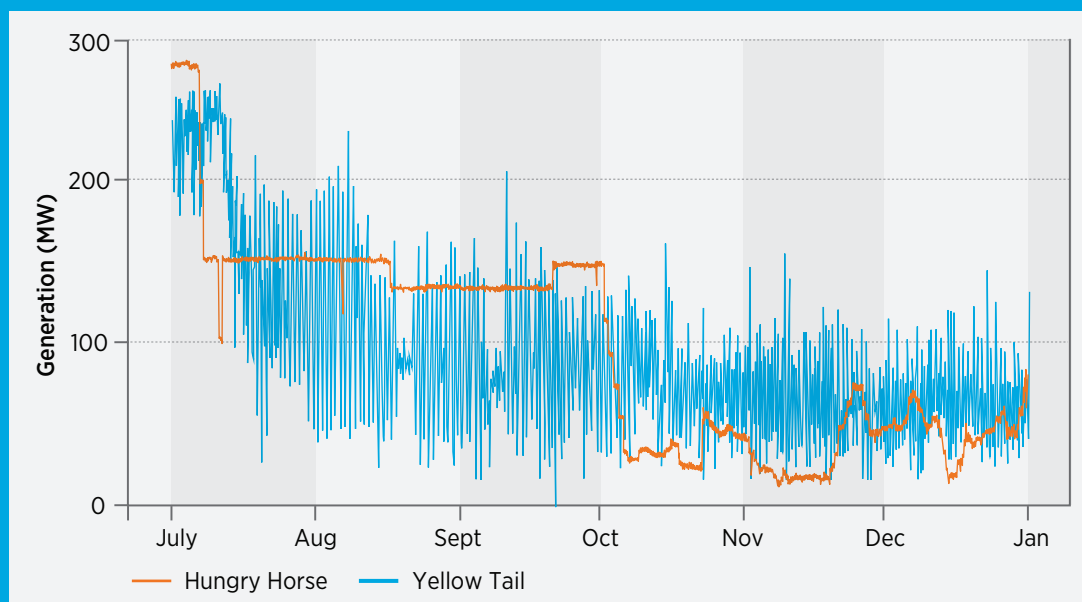

Hourly generation from Hungry Horse (red) and Yellowtail (blue) dams in the second half of 2010

Sources: Army Corps NWD Database [81], WAPA TEPPC [82]



## 2.2.4 Pumped Storage Hydropower Capabilities

Compared with other hydropower facilities, PSH facilities typically have fewer operational and environmental constraints.<sup>26</sup> PSH facilities have traditionally served two primary functions in the electrical system: (1) providing energy storage and shifting system demand from peak to off-peak periods; and (2) providing backup capacity in case of outages of large thermal or nuclear generating units. PSH plants are able to start quickly and have high ramp rates, characteristics that allow such plants to provide high generating capacity in a short time period. These operational characteristics contribute to greater flexibility and reliability of power system operation [83]. A common use for PSH is to perform a type of arbitrage—storing electricity when prices or operational system costs are low, and producing electricity when prices/costs are high.

The operational flexibility of PSH facilities makes it possible for these systems to provide key ancillary grid services, such as a combination of spinning and non-spinning reserve components of contingency reserves. Most PSH plants can increase output (ramp up) quickly and reach maximum installed capacity within 10 minutes. PSH plants can also provide frequency regulation and other ancillary services. While fixed-speed PSH plants can provide regulation reserve only in the generating mode of operation, advanced adjustable-speed<sup>27</sup> PSH units can provide regulation service in both generating and pumping modes of operation. Most PSH technologies can switch from full pumping to full generation in several minutes [84]. See Section 2.7 for more information on these designs.

In addition to energy and grid services, PSH plants also provide a number of other benefits to power systems. For example, PSH plants provide a flatter net load for thermal generating units, allowing the units to reduce cycling and operate for longer periods of time at more efficient set points, especially in small systems [83]. PSH plants can also provide the load and

energy storage for excess variable generation (VG), thus reducing the curtailment of this generation.<sup>28</sup> This supports integration of a larger share of variable renewables into the power grid by storing energy when energy has a low value, and releasing energy during periods of high value.

## 2.2.5 Transmission Aspects Specific to Hydropower

By its nature, hydropower generation is constrained to be located along river basins with sufficient characteristics to support impoundments and power generation equipment. Transmission is necessary to deliver electricity from hydropower in these river locations to demand centers. Figure 2-20 illustrates that the greatest period of transmission expansion coincides with the development of hydropower and baseload units in the 1960s and 1970s. The figure also shows that the level of overall transmission expansion in the United States has increased slightly relative to the period 1990–2005.

This section describes the geographic distribution of electricity demand in the United States, along with the overall structure and characteristics of the transmission network relative to demand centers and the location of existing hydropower facilities. New transmission is built primarily to provide a combination of the following functions and benefits:

- **Connecting new sources of generation.** Some new generation is located far from load centers, and transmission must be developed to deliver energy over these potentially large distances.
- **Connecting new or growing load areas.** Growing cities or new sources of demand may need new transmission to connect with the grid or support higher demand.
- **Increasing or maintaining reliability.** In some cases, new transmission can strengthen the grid, resulting in better performance and/or higher reliability (i.e., fewer consumer outages or better system balancing as measured by resource adequacy, frequency excursions, or NERC control performance standards).

26. For instance, many PSH facilities use at least one reservoir that is not part of the normal hydrologic system. This enables relaxation of some of the constraints that challenge typical hydrologic systems.

27. There are no adjustable-speed PSH units located in the United States as of the end of 2015.

28. In cases where curtailment can be reduced, periods of excess generation can be mitigated by storing excess energy through pumping water at the PSH facility.

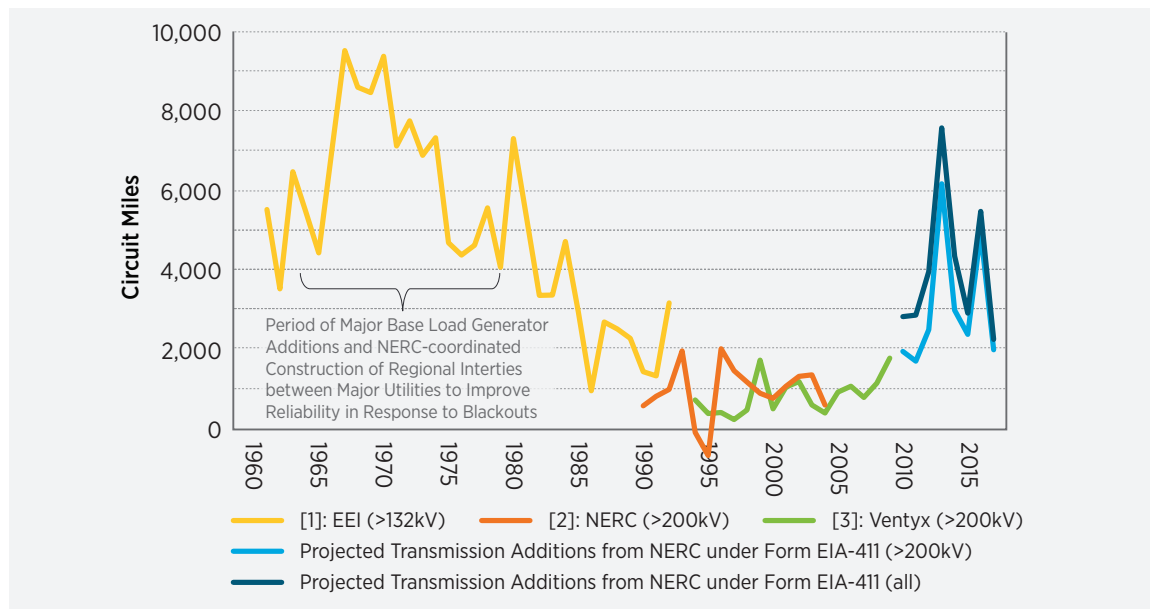

Note: Most of the existing grid was built 30-50+ years ago. Even relatively high recent and projected circuit miles additions are below levels of additions in 1960s and 1970s

Source: Pfeifenberger 2012 [85]

**Figure 2-20.** Historical high-voltage transmission additions in the United States

- **Reducing system-wide operating cost.** Connecting neighboring systems with a strong transmission tie may result in better use of less costly generation sources, and can link together markets of the electrical bulk-power system.

In some cases, new transmission can deliver a combination of these functions and advantages. In all cases, rigorous cost/benefit analysis is needed and must be accompanied by public stakeholder processes that address transmission development in cases of public opposition, environmental considerations, and controversial allocation of new transmission costs. Expanding the transmission system has become increasingly challenging because of environmental and cost allocation concerns; thus, the issue of limited transmission expansion is widespread. There are examples of approaches that have been used effectively to determine the value of new transmission, and methods that have helped ensure that incremental transmission additions do not prove inefficient in the long run. For instance, the Midcontinent ISO (MISO) Multi-value Project process does not directly attempt to place an

economic value on reliability. Instead, potential new transmission is analyzed in Multi-value Project using extensive production cost modeling.<sup>29</sup> The resulting benefit calculations are compared to costs so that cost-effective solutions can be pursued [86].

Another approach, with different objectives, is Competitive Renewable Energy Zones, known as CREZ. In 2005, the Texas Legislature passed a law requiring the Public Utility Commission of Texas to designate Competitive Renewable Energy Zones as locations in which renewable energy would be developed. The Commission was also required to approve transmission improvements that would connect these selected zones with load centers. The Public Utility Commission selected five Competitive Renewable Energy Zones for wind power development in 2008 and defined the transmission improvement plan required to bring the generated power to consumers. The primary objective was to reduce costs over the long run by avoiding the need for multiple lower voltage lines to the same region over time, as compared to capturing economies of scale by building a line of sufficient capacity to serve future needs in addition to current needs [87].

29. Production cost modeling involves a simulation of the power system operation, usually for one year or more, and provides a large number of outputs and metrics. These can be used to help assess the cost or benefit of any change to the system, and to evaluate congestion, the operational impact of deferred generation, and many other potential changes to the power system.

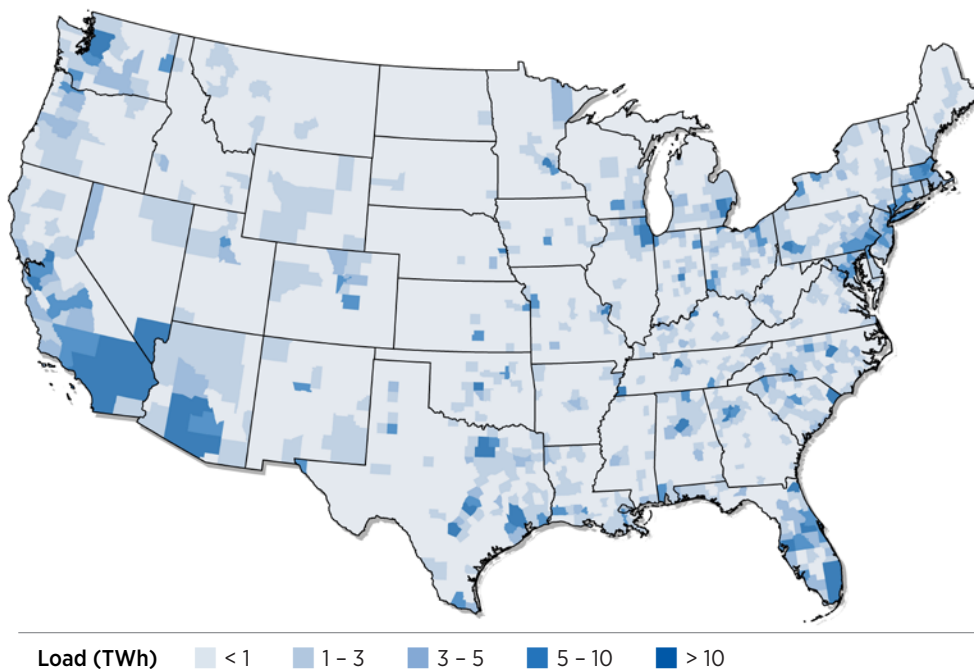

Source: National Renewable Energy Laboratory. Data extracted from ABB Energy Velocity Suite [88]

**Figure 2-21.** Distribution of electricity demand by county in the United States

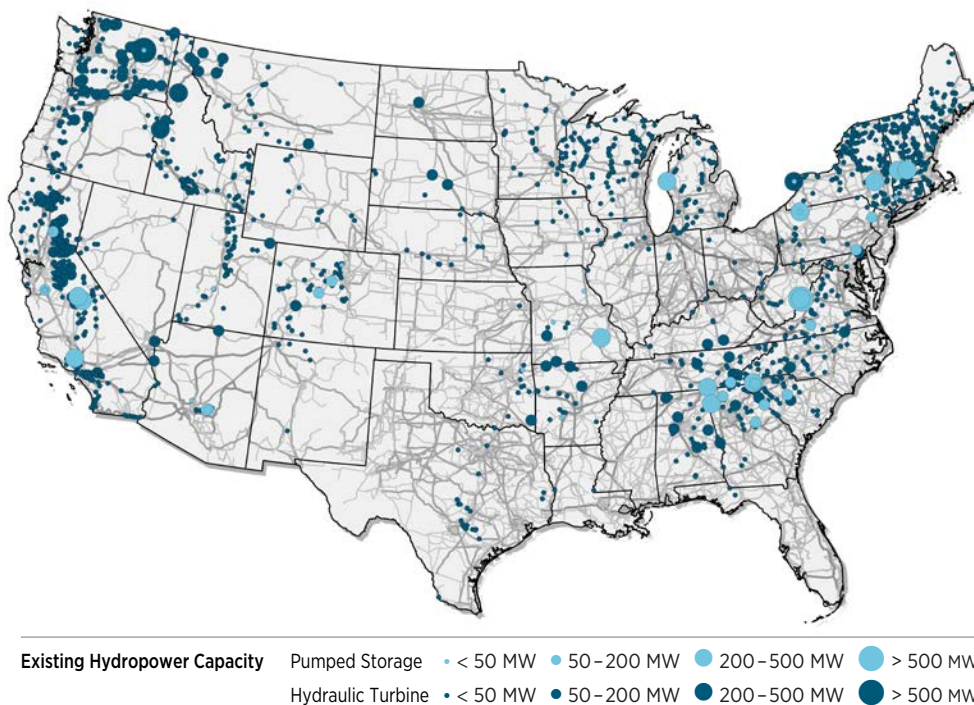

Source: National Renewable Energy Laboratory. Data extracted from ABB Energy Velocity Suite [88]

**Figure 2-22.** Location of existing hydropower capacity in the United States, along with the transmission network

Figure 2-21 illustrates how electricity demand is distributed around the country. The density of demand is generally a function of population, and the map illustrates population centers along the East Coast, parts of the South and Midwest, and along the West Coast as having the highest demand.

Existing hydropower facilities are partially reflective of demand patterns, but are more closely aligned with the availability of potential hydropower resource (Figure 2-22). As shown, hydropower generation is greater in California and the Pacific Northwest, in and near the Tennessee Valley, and in parts of the upper Midwest and Northeast. The map distinguishes PSH from other hydropower, and shows the relative size of the units. Because PSH is dependent upon elevation differences between upper and lower reservoirs, such facilities are more common in (but not entirely confined to) mountainous regions. Figure 2-22 also overlays the transmission network with hydropower locations.

## 2.2.6 Transmission Interactions with Canada

Canadian hydropower development and the country's transmission system are integrated with the U.S. power system. Hydro Quebec has interties<sup>30</sup> and energy transactions with New York and New England, while Manitoba Hydro is part of the MISO market area (Figure 2-14) and is integrated into bulk-power system market operations in that part of the country. The amount of transmission capacity interconnecting the two countries varies as a function of geography. BC Hydro and PowerEx have extensive hydropower and interconnection into the northwestern United States, although the operational coordination is somewhat less than in MISO because there is no organized wholesale power market in that region of the United States.

Canadian hydropower resources have similar characteristics to U.S. hydropower. The multiple uses of water in Canada, however, do not appear to constrain electric operations to the same extent as in the United States. In the Canadian system, power generation is the priority at many Canadian multi-purpose water resource (or dam) projects. The Canadian system also has more hydropower storage, which increases the ability of these resources to manage inter-annual or other shorter term weather fluctuations that

influence the hydrology—and, therefore, the energy available from the dams. This greater availability of energy, coupled with better ability to manage this energy, makes Canadian hydropower resources more flexible than those in the United States. This suggests the potential to help manage the variability and uncertainty that is part of power systems operation [89], particularly in the United States. These factors are likely to increase as new variable energy sources, such as wind and solar power, are added to the resource mix, and hydropower can play a role in integrating these sources. In regions of the United States and Canada that are already integrated via bulk-power system markets, much of this coordination is implicitly in place. In regions that lack organized markets spanning parts of the United States and Canada, this coordination is less developed, limiting the ability of Canadian hydropower to help balance VG.

## 2.2.7 Transmission in Hawaii and Alaska

Each of Hawaii's six islands with utility services has its own electrical grid and must supply its own power (Figure 2-23). Kauai Island Utility Cooperative services Kauai; Hawaiian Electric Company services Oahu; Maui Electric Company services Maui, Molokai, and Lanai; and Hawaii Electric Light Company services Hawaii island. Hawaiian Electric Company, Maui Electric Company, and HELCO are known collectively as the Hawaiian Electric Companies, and provide power to about 95% of the state's population.

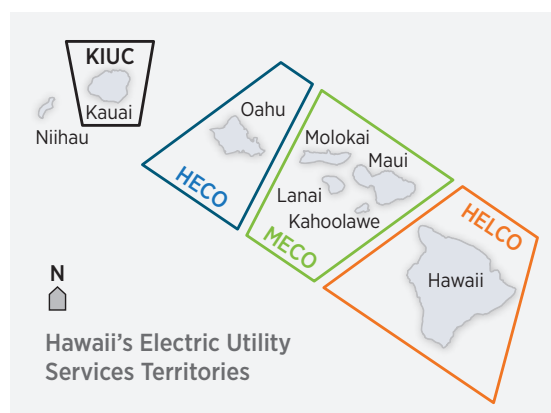

Source: Hawaii DBEDT [91]

**Figure 2-23.** Division of Hawaii's electric utilities

30. An intertie refers to a transmission link that joins two (or more) neighboring electrical areas of the grid. This connection allows for varying level of operational coordination between neighboring entities, which can often reduce cost, increase reliability, or both.



Hawaii's electric utilities generate and distribute electricity from their own power plants and purchase energy for redistribution from numerous independent power producers (IPPs) statewide [90], including hydropower producers.

In Alaska, approximately 80% of the population resides in the geographic area known as the Railbelt. This region stretches from Fairbanks through Anchorage and to Homer at the tip of the Kenai Peninsula. The Railbelt is electrically connected via utility and state transmission assets that provide a means of conveying electricity from the state-owned Bradley Lake Hydroelectric project near Homer, Alaska, to the six regulated public Railbelt utilities.

Generation sources for the Railbelt include hydropower from Bradley Lake, Eklutna Lake, Cooper Lake, and South Fork. These hydropower sources are supplemented by thermal generation using coal at Healy, coal and diesel at Fairbanks, and natural gas-fired combustion turbines in Nikiski, Soldotna, Anchorage, and Eklutna. Wind farms add energy from Fire Island near Anchorage and Eva Creek near Healy. Integrated Resource Plan modeling of the Railbelt electrical system has been conducted, with the assumption of load growth of approximately 1% per year. This projected load growth could be affected by resource development projects, including mining and a pipeline to transport natural gas from the North Slope to tidewater for export.

Southeast Alaska relies on hydropower for nearly 90% of its electric generation. The communities of Ketchikan, Wrangell, and Petersburg are connected electrically through a transmission system owned by the Southeast Alaska Power Agency, with hydropower resources meeting a large portion of electrical needs. Projects have been undertaken on this system to add water storage capacity to the existing hydropower generation.

A predominantly hydropower-based interconnected electric system with diesel backup serves the eight communities on Prince of Wales Island, in southeastern Alaska. The capital city of Juneau and the city of Sitka are separate hydropower-based communities that have added capacity to their systems. Juneau accomplished this through construction of new generation at Lake Dorothy, while Sitka raised the height of the existing dam at Blue Lake.

The Upper Lynn Canal sub-region receives its electric power via a single contingency transmission system that connects the utilities serving Haines and Skagway. The source of electric power for this area is primarily hydropower generation, with diesel augmentation that carries a greater part of the load when run-of-river hydropower is not possible. The governments of Alaska state and Yukon Territory evaluated an electric connection with the islanded electric system serving Whitehorse and smaller communities in the Yukon Territory. The study concluded this connection could provide cross-border benefits if business development, such as shore-side power for cruise ships, is negotiated. An interconnected system would provide the means for additional renewable hydroelectric resources to deliver energy to customers.

The balance of the state, rural Alaska, consists of a patchwork of mostly isolated communities with limited infrastructure. The communities use primarily diesel generation for their power supply. In fiscal year 2015, the 184 largest communities in rural Alaska had a combined population of 83,400 residents [92]. For the most part, village centralized power systems are isolated grids that are not interconnected due to the low loads, topography, and long distances that separate them. Through the Alaska Energy Authority, the state provides economic assistance via the Power Cost Equalization program to communities and residents in rural Alaska burdened with high power costs. Other Authority programs include rural power systems, bulk fuel upgrades, and village energy efficiency. Alaska Energy Authority also provides technical assistance with operations issues (reliability and efficiency) of the power plants for these remote villages; training for bulk fuel and power plant operators; and more advanced training for hydropower facility operators.

In some cases, hybrid micro-grids containing hydropower generation and at least one alternative energy resource are proposed or in place where Alaska Energy Authority assists with the integration of local renewable energy resources. Hydropower is used where available, such as in Kodiak, where the electric utility is supplied by 80% hydropower and 19% wind. The Copper Valley Electric Association's mix of hydropower and diesel in Valdez is connected via transmission to the utilities' diesel generation in Glennallen. Gustavus, Chignik Lake, Larson Bay, and Atka all have small run-of-river hydropower that provides most electricity, augmented by standby diesel.

## 2.2.8 Power System Planning

Power system planning involves predicting the future state of electricity demand and using this information to design and invest in sufficient, cost-effective generation, transmission, and distribution so that the power system can operate reliably. Although there is no uniform approach across the United States, the general planning process typically involves analysis of potential future resources needed to satisfy future demand (resource planning) and new transmission that may be needed to deliver energy to load centers (transmission planning). Because of the interplay between resource planning and transmission planning, they necessarily overlap.

The characteristics of the generation portfolio must match electricity demand, and hydropower may in some cases be a good match. In other cases, hydro-power may not be the best choice to supply new generation or may be infeasible for development. These issues are discussed further in Section 2.4.

When evaluating suitability of new generation resources, questions that are considered include:

- Will the resource help meet the anticipated future demand?

- What is the relative economic value of the capacity and energy that this resource can provide relative to alternatives?
- What characteristics in terms of flexibility are needed for the power system to be balanced and reliable, and which of these characteristics can the candidate resource provide?
- What is the timing of the energy delivery from the resource?
- What is the likely inter-annual and long-term variability around the energy and services that the resource can provide?
- What is the net environmental impact of the resource relative to other alternatives?
- What are the risks associated with all of these factors (and perhaps others)?

These questions represent the types of issues that must be considered for any new power resource. Hydropower facilities can generally provide flexibility in power systems operation. Runoff can vary significantly from year to year, however, and the potential variations and timing of both energy delivery and grid services must be considered. The value of the energy and grid services that hydropower can provide can be

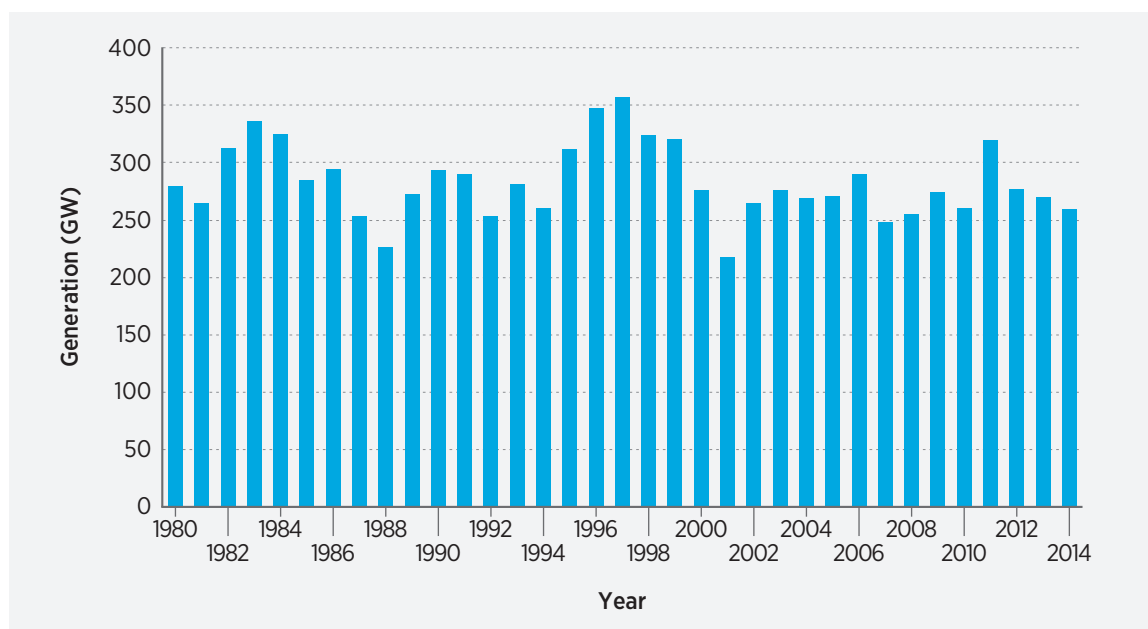

Source: data from EIA 2013 [93]

**Figure 2-24.** Annual generation by hydropower in the United States from 1980–2014

evaluated by using electricity production simulation tools to compare the operational and economic value of hydropower against other options.

Historical data of operations exist for most hydropower locations and can help support planning studies. Figure 2-24 presents total generation from hydropower in the United States between 1980 and 2013. Variances across years can include the influence of weather and precipitation, and can be greater when examining individual balancing authority areas or river systems.

## 2.2.9 Emerging Issues Related to Transmission

Opportunities for hydropower could not only enable a higher level of participation of the technology in electric systems, but may also potentially increase plant operating revenues earned from selling energy and ancillary grid services. This section discusses changes in the electrical bulk-power system and ways in which hydropower may be able to support those changes.

**Evolution of the Power System.** As of 2015, there has been a transformation in how the grid and power system are operated, influenced in large part by the integration of variable renewable generation, e.g., wind and solar energy. In the future, electric vehicles, distributed generation, smart grid functions, and other changes could further affect grid operations. These shifts may challenge hydropower facilities to operate in ways that were not considered when the facilities were designed. To support new functions, hydropower facilities may not physically change, but their operations might. A vision of future hydropower resources needs to be robust with respect to the myriad of possible future changes to the electricity system.

Renewable resources such as wind and solar are low marginal cost energy resources because they have no fuel cost (as compared to resources like natural gas or coal generation), and are frequently incorporated into utility systems via “take or pay” contracts. Because VG is often not dispatchable in the traditional sense because the associated fuel—wind or sunlight—is not always available,<sup>31</sup> it essentially appears as negative load in the system. During times of low wind and/or solar energy generation, the remaining generators

make up the difference, providing the remaining generation required to meet demand. This residual demand is called net load, or net demand. This means that dispatchable generators are tasked with balancing the *net load* of the system; that is, the load minus VG. As the penetration of VG energy increases, the character of the net demand changes—sometimes dramatically—compared to the demand alone.

Both wind and solar can, however, be dispatched down. In addition, the power electronics embedded in the wind turbine or solar inverters can respond to automatic generation control signals. These capabilities make it possible for VG to be included in market operations and are now in use by MISO, New York ISO, and others.

Past studies and operating experience have shown that introducing variable renewable generation such as wind and solar power into a balancing area will increase the regulation requirements and need for reserves due to the inherent variability and uncertainty associated with such resources (e.g., GE Energy 2010 [94], Acker 2011a [95], Ela et al. 2011 [96], Exeter et al. 2012 [97], Palchak and Denholm 2014 [98]). Reserves are provided by the more agile generation (or load) resources on the electrical system, and these resources serve to make the system more “flexible” and capable of adapting to both expected and unexpected changes. When there is significant VG in a given system, hydropower can provide significant value if it can contribute towards meeting the net demand (demand minus VG). The net demand has more variability and uncertainty than demand itself. If this net demand can be met without curtailing VG, this is generally the most cost-effective way to integrate VG.

Studies have also determined that systems with greater flexibility can more easily incorporate higher levels of VG penetration. In fact, flexible use of hydropower can reduce system operating costs in the presence of high VG penetration while accommodating primary hydropower constraints (e.g., competing uses) [99, 100]. Wind and solar penetration—perhaps ranging up to 10%–20% of demand—can sometimes be accommodated with little or no changes to system operational practices, but operational coordination between balancing authority areas—especially small

31. The use of power electronics in power inverters, coupled with power markets or operational practice that can incorporate this capability, can allow for VG to provide limited dispatchability in some conditions.

ones—can improve integration effectiveness.<sup>32</sup> As wind and/or solar energy penetration levels exceed 20% of annual energy demand, it is possible that changes to the standard practice of system balancing will be required (e.g., increased frequency of scheduling, balancing area coordination).

**Potential Opportunities to Enhance the Value/Use of Hydropower.** Hydropower contributions to system flexibility are typically represented in a simplified fashion in VG integration studies, because the complex interactions between hydropower generators in the same river basin do not always fit within the modeling framework. While hydropower is an inherently flexible generation resource, the estimation of available flexibility under radically different operational conditions is an arduous task and is often beyond the scope of such studies. More details about VG integration in systems with hydropower can be found in several resources (e.g., Acker 2011a [95], Acker 2011b [101], GE Energy 2010 [94], Acker and Pete 2012 [99]). These studies show that utilizing the ability of controllable hydropower generation (including PSH and dispatchable), the timing of hydropower generation can help maintain system balance while reducing operational cost. This operational cost reduction is compared to operational cost that would be incurred if the hydropower generation were totally inflexible compared to a scenario with no VG.

It is also possible that, at least in some cases, the level of flexibility that hydropower can provide—even considering the many non-power constraints—may not be accurately captured in some modeling frameworks. A 2014 study by Ibanez et al. [102] found that detailed modeling of the Columbia River Basin for a selected week identified additional flexibility available from hydropower, as compared to what is found by more traditional electric power production simulations. While this study included only a week of simulation on a single river basin, the findings indicate that additional work applied more broadly to hydropower will likely be able to further identify and capture a more accurate representation in a hydropower system. Results from this limited study cannot

be reasonably extrapolated to other cases, but they do indicate that there may be more flexibility available than is generally captured in traditional modeling approaches. It seems reasonable to conclude that the potential exists to better understand the flexibility of hydropower and how it can support VG integration.

In some regions, it may be possible to increase the flexibility in hydropower operations by modifying operational procedures and/or wholesale energy market designs. This potential improvement is constrained by physical operational limits and by the competing priorities on river flow. For example, 2013 research by the Electric Power Research Institute (EPRI) found that hydropower facilities in both structured market and non-market areas<sup>33</sup> have opportunities to improve plant efficiency [103]. Wholesale energy markets are discussed further in Section 2.1.2 and Section 2.3.1.

The EPRI study also demonstrated that upgrades to plant equipment for PSH can add value by increasing the operating range. This can be done through mechanical changes, without installing new hydropower units, and can increase PSH revenue by 61%. In addition, advancements to variable-speed or adjustable-speed drives have enabled PSH facilities to be more flexible and offer grid services while pumping, which allows for increased revenue from ancillary grid services. This also allows for provision of frequency regulation, reduced cycling of thermal fleet, and an increase in the amount of time the unit can be operated at its maximum output under a wider range of head conditions. These additional changes, which facilitate lower minimum load and higher efficiency, can increase revenue by up to 85% at a fraction of the cost of new PSH development [103].

## 2.2.10 Trends and Opportunities

Trends and opportunities for hydropower related to hydropower's Role in the Grid include:

- Development of future hydropower resources will occur in the context of a myriad of possible changes to the electricity system.

32. Increasing the coordination between balancing areas improves system economics (regardless of VG penetration) by enabling access to more diverse generation assets and load behavior, and reducing the need for reserves. Simultaneous incorporation of greater amounts of VG and increased coordination of balancing areas enables offset of additional flexibility required for VG by the flexibility gains acquired. California has adopted a 50% renewable generation requirement by 2030, and is part of the expanding Energy Imbalance Market in the west that is a good example of operational coordination across wider geographic and electrical areas.

33. "Non-market areas" refers to the parts of the United States that do not have large coordinated markets. These non-market areas are outside of RTOs and ISOs (see <http://www.isorto.org/about/default>).



- Quantifying the flexibility in hydropower is a prerequisite for determining the value of hydropower-provided flexibility. This will become increasingly important as the development of VG continues for the foreseeable future. This is a dynamic process and will change as hydropower and VG capabilities evolve, and weather and climate vary.
- Improvement in the deployment of hydropower flexibility to reduce system operating costs in the presence of high VG penetration, while accommodating competing uses.
- Integration of physical infrastructure, governing organizations, and regulations to maximize utility and benefits of hydropower while meeting priorities and complying with regulations.
- Utilization of electricity production simulation tools to determine the value of the energy and grid services that hydropower can provide can be pursued by comparing the operational and economic value of hydropower against other options.

## 2.3 Markets and Project Economics

Hydropower facility owners realize value from two primary sources: power markets and environmental markets (e.g., RPSs). While the structure and operation of power markets vary across the nation, common roles for hydropower are electricity generation and flexibility to provide various grid services. Environmental markets such as those created by RPSs can provide additional value to hydropower owners, but are based on market- and region-specific considerations of hydropower as a sustainable, renewable, or “green” power resource. Federal and state incentive programs also play a role in project economics by valuing existing and new hydropower assets, with the availability of these incentives based on asset ownership and resource characteristics.

### Highlights:

- Increasing penetrations of variable renewable generation are changing the way the grid is operated and the way hydropower and other generation is compensated.
- Facility ownership plays a key role in determining access to revenue streams and the investment perspective underlying how hydropower is valued.
- Treatment of hydropower as a renewable resource is not consistent from state to state, which complicates hydropower marketing.
- Canadian hydropower is playing an increasing role in U.S. electricity markets.

Ultimately, the combination of power markets, environmental markets, and project economics create the revenue streams upon which hydropower facilities are developed and operated. This section explains hydropower’s role in power and environmental markets and discusses project economics.

### 2.3.1 Power Markets

Supplying electricity, balancing the power system, and responding to system emergencies are the primary roles of hydropower—and, coupled with providing peaking capacity to ensure the grid has adequate capabilities to meet peak electricity demand, are the technology’s primary sources of value. The manner in which non-federal plants operate and are compensated within the power system is highly dependent on the structure of the market and regional factors influencing and constraining the supply of electricity. With respect to federal hydropower projects, operations are highly dependent on both existing power sales contracts and market dynamics although operations can be influenced by other authorized purposes such as flood control. Within the continental United States, hydropower facilities can operate as part of formally structured competitive markets of ISOs and RTOs; be operated external to these market areas by an electric utility or independent power producer; or—in the case of the federal hydropower fleet—produce power in an explicitly multi-purpose context to be sold by PMAs. The isolated Alaskan and Hawaiian markets have unique economic and technical constraints on their power systems, which in turn create unique circumstances for electric generation sources.

### *Bilateral Markets/Non-Market Areas*

In vertically integrated<sup>34</sup> markets (that is, where generation, transmission, and distribution are all owned by the utility), utilities source power to meet customer demands through self-supply, bilateral contracts with other utilities, short- and long-term purchases from IPPs, or purchases from other individual market participants as necessary. Within this context, hydropower can be a cost-effective asset given the low cost of production [104] and the possibility for portfolio savings, such as those from decreased wear and tear facilitated by reduced need for stops and starts in thermal generators. These portfolio benefits<sup>35</sup> could ultimately be reflected in the internal valuation of hydropower as a rate reduction tool by utilities.

In the long-term resource planning context, hydropower's low variable O&M costs [104] can stabilize future prices for ratepayers. Renewable power is often considered a hedge against future fossil fuel price volatility. This value is documented in the structure of bilateral wind power purchase agreements (PPAs), and is present even in an era of low gas prices [105]. The additional flexibility of hydropower facilities builds upon this energy value by reducing the need for fossil fuel capacity to provide reserves and ancillary and essential reliability services to the grid. However, major climatic and weather variability—such as extreme drought conditions—can reduce the certainty of water availability for power production.

From an operations standpoint, the presence of flexible hydropower resources in mixed hydro-thermal systems can enable utilities to keep coal, gas, and nuclear facilities generating at stable operating points that are more efficient than they would be without hydropower included. This type of system efficiency can lower fuel costs and reduce wear and tear on thermal assets by eliminating excessive ramping. The strategic water management capabilities provided by hydropower storage furthers co-optimization of hydropower and thermal generation through the

release of colder water for use in thermal cooling at plants further downstream, and the maintenance of adequate reservoir levels at thermal water intakes. These benefits from integrated operations are another example of the portfolio benefits potentially afforded by hydropower.

### *Markets Administered by Independent System Operators and Regional Transmission Organizations*

Outside traditional vertically integrated market structures in which utilities are able to directly use hydropower to optimize their power generation portfolio, the value of hydropower assets depends on the extent to which restructured ISO/RTO markets efficiently reward generators for the full value they provide to the power system. The range of capabilities provided by hydropower resources can allow projects to maximize value in competitive markets through generation during times of higher energy prices as well as participation in markets for more highly valued ancillary and essential reliability services. The ability of hydropower to extract maximum value from markets is often constrained, however, by regulation and market mechanisms, technical design limitations, and competing non-electricity water uses. Varying market structures, participation opportunities, and prices introduce a regional component into the extent and magnitude of compensation that hydropower assets receive for contributions to the power system.

**Value from Energy Production.** The market for energy has historically been a primary source of the value available in wholesale markets. The magnitude of this value for hydropower is dependent on the ability of a hydropower facility to generate during predictable system conditions as well as unpredictable ones, the latter of which can create higher prices. Shifting or withholding water releases for generation during higher value times of the day (“peaking”) is contingent on a project’s storage capability and the

34. Electricity markets were subjected to a national wave of reforms in the late 1990s and early 2000s, focused on introducing more competitive mechanisms to the traditional vertically integrated, investor-owned utility model. By 2012, more than a third of U.S. generation was produced by IPPs, essentially the generation facet of a traditional IOU, uncoupled from the transmission business components. Many of the markets in which these IPPs operate collectively formed larger centralized markets (ISOs/RTOs) that oversee regional operations and help to manage the grid [106]. These ISO/RTO markets typically cover areas where generation and distribution services are procured on a competitive basis. Areas in which generation, transmission, and distribution services are provided by state-regulated entities are referred to as “vertically integrated” or “non-market” regions. The footprint of some formally organized markets, however, such as MISO and the Southwest Power Pool, include fully regulated, “non-market” states.

35. It is important to note that portfolio benefits are still realizable in competitive markets, but that these benefits accrue separately to generation, transmission, and load. In theory, these benefits can be factored into market resource planning processes, but are at risk of being ignored or undervalued if products for these benefits do not exist.

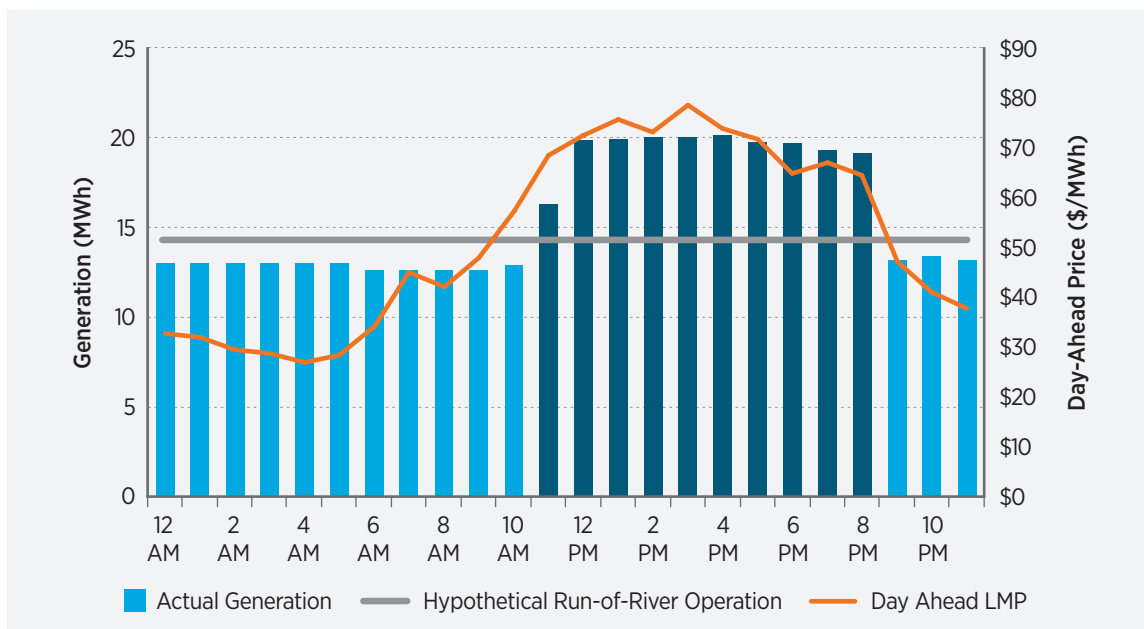

Notes: Shaded hours (11 AM – 8 PM) show the preference for generation during the highest value time periods; a facility with complete operational flexibility would shift all generation to these hours. LMP is “locational marginal price” (i.e., price at a specific location).

Source: FERC, 2014e [107]

**Figure 2-25.** Example participation of a hydropower plant in ISO New England energy markets (example date: September 2, 2014)

regulatory requirements governing its operations. The operation of many hydropower plants also is subject to alternative water use demands, such as off-peak water releases for environmental or recreational purposes; municipal, industrial and agricultural water supply; ramp rate restrictions; or limitations in up-stream reservoir level fluctuations.

Whereas peaking plants have usable storage from the project’s reservoir, run-of-river facilities have little to no ability to time-shift water releases. This rigidity can be the result of either technical constraints (e.g., no storage capacity) or regulatory mandates that water releases must closely match water inflows into a reservoir. Run-of-river facilities receive less compensation compared to projects with storage, since more of their generation occurs during less valuable time periods (i.e., such facilities cannot take advantage of

any price changes in the market). As an illustration, Figure 2-25 captures the actual daily operation of a hydropower facility in ISO New England and a hypothetical run-of-river operational scenario where the plant’s generation is flat throughout the day. This example facility’s high minimum operation throughout the day indicates the facility is not a purely peaking project. Even with its limited operational flexibility, however, the facility earns at least 16% more by shifting generation to peak hours than would be possible under pure run-of-river operations.<sup>36</sup>

No matter the operational flexibility of hydropower resources, the value of energy production varies regionally based on market-specific structure and the resulting prices for energy, ancillary services, and capacity products. Figure 2-26 plots representative wholesale annual average energy prices for various

36. Separate from run-of-river operations, hydropower facilities added retroactively to federal water resource infrastructure (such as the powering of Corps or Reclamation non-powered dams and conduits) operate under a unique set of circumstances. In such cases, the ability to generate power is contingent on the infrastructure owner’s decision to release water. When FERC regulation applies, these projects are generally licensed as “run-of-release.” When developed under the Reclamation Lease of Power Privilege process, Reclamation’s operating guidelines apply. Many of these projects have the capability to generate during periods of peak demand and prices, but this can only occur if the dam or canal owners are willing to schedule water releases during these times. Often, original dam purposes such as water supply or navigation require carefully timed releases, and operational flexibility is minimal. However, some dam purposes such as flood management may offer more flexibility in the timing of releases to improve value opportunities for facility owners.

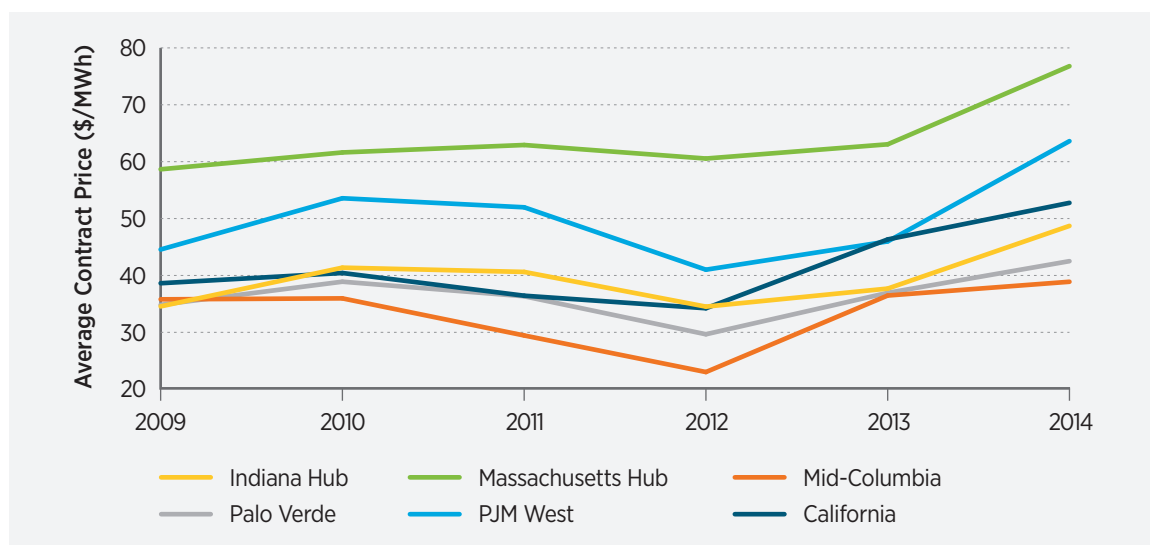

Source: EIA, 2014 [112]

**Figure 2-26.** Example of six regional U.S. wholesale energy prices, annualized 2009-2014

regions throughout the country, which in 2014 ranged from approximately \$40 to \$80/MWh [108]. Local fuel mix and transmission constraints influence the value received by generators for producing energy, and price differentials within a single ISO can be equivalent to the differences in average prices between ISOs.<sup>37</sup>

U.S. markets are increasingly driven by natural gas prices, as combustion turbines or combined cycle gas turbines are often the marginal generation technology in several ISOs [109]. One exception to this is the Northwest Power Pool, a sub-region of the Western Electricity Coordinating Council, where the power system is 60% hydropower [110]. This hydropower can become the marginal generation technology during periods of high flow, resulting in the lower energy prices at the region's Mid-Columbia hub (Figure 2-26).

**Value of Grid Service Markets.** In addition to value derived directly from generating power, the fast response and storage capabilities of hydropower facilities allow for extraction of additional value

through the provision of ancillary grid services, including designated essential reliability services (see Text Box 2-2a and Text Box 2-2b). The value an individual plant can generate in ancillary service markets can vary from facility to facility based on technical capabilities and market needs and arrangements. Most facilities in the United States possess the physical ramp rates and response times necessary to bid into spinning and non-spinning reserve markets,<sup>38</sup> although maximizing value from energy and ancillary services may not be possible due to regulatory operating constraints. Despite this, even run-of-river/run-of-release facilities are capable of providing frequency regulation services, although doing so may require appropriate stipulations in their FERC operating licenses.<sup>39</sup> Hydropower projects are also capable of supplying black start services.<sup>40</sup> During the 2003 blackout, large hydropower stations anchored some islanded areas that maintained power and served as the basis for restoring services to larger areas, including Ontario and New York [113].

37. As an example, New York ISO 2013 wholesale energy prices in the Long Island zone were approximately \$75/MWh, compared to the \$40/MWh seen in western New York [111]. Of note, hydropower plays a major role in western New York through the energy supplied by the New York Power Authority's Niagara Power Project.

38. In an update to the Energy Information Administration's Form 860, more than 80% of reporting hydropower capacity (inclusive of PSH) is listed as capable of ramping from cold shutdown to full power within 10 minutes. In an update to the Energy Information Administration's Form 860, more than 80% of reporting hydropower capacity (inclusive of PSH) is listed as capable of ramping from cold shutdown to full power within 10 minutes.

39. For example, some developments within the Missouri Madison project (FERC No. 2188) have run-of-river explicitly defined to only exclude peaking, load-following, and the provision of non-spinning reserves.



While there is no systematic national scale data on hydropower's provision of ancillary grid services [116], the results of simulation studies have illustrated potential contributions on a regional basis. For example, value from simulated market operations identified in a 2013 EPRI study [80] suggested that, on average, hydropower in the Western Electricity Coordinating Council (Figure 2-27) would obtain only 4% of its revenues from ancillary services. This value, however, varied regionally, from a low of 2% in the hydropower-dominated Northwest Power Pool up to 20% of total revenue in the Rocky Mountain Power Area.

Regional-scale analyses can capture aggregate trends in hydropower ancillary service revenues and highlight key issues of market scale where ancillary services can comprise relatively small amounts of overall power system production costs. For example, FERC has required ISOs to structure frequency regulation markets such that better performing generators are compensated appropriately [118]. While such market changes are ongoing, initial results from the PJM Interconnection suggest that improved market

designs better compensate high performers,<sup>41</sup> such as existing fast-responding hydropower generators, while shrinking the quantity of reserves necessary to ensure grid stability because of improved certainty in regulation performance [119].

**Value of Capacity.** Capacity markets are intended to provide an additional source of revenue to ensure supply adequacy in markets. These markets can be particularly important for hydropower—which requires long-lived, capital-intensive investment in what amounts to core power system infrastructure. Capacity procured in forward markets must be available when called upon to meet periods of high demand; otherwise, generators or face underperformance penalties. Because of this, hydropower facilities with reliable storage and flexibility are able to commit larger portions of their generation capabilities, increasing the amount of value captured in these markets. Given its inherent nature as a storage technology, PSH in particular can rely on much of its capacity to be available; hydropower facilities with less operational flexibility may bid less capacity to

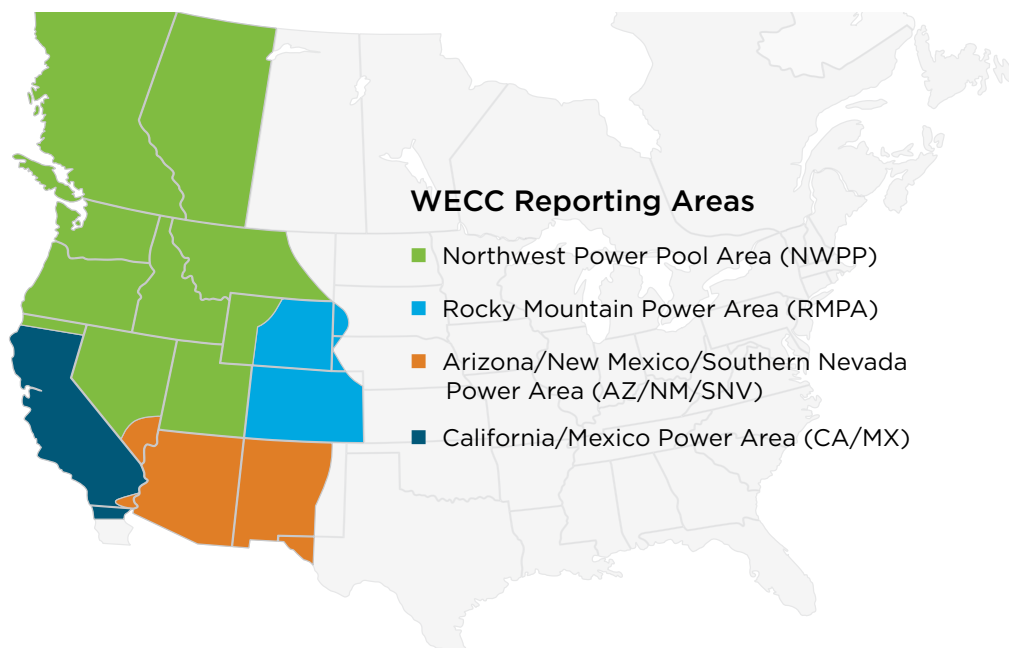

Source: FERC [117]

**Figure 2-27.** The four Western Electricity Coordinating Council reporting areas

41. That is, those generators that can respond quickly and effectively in a variety of situations, or flexible facilities that can come online and ramp up or down quickly.

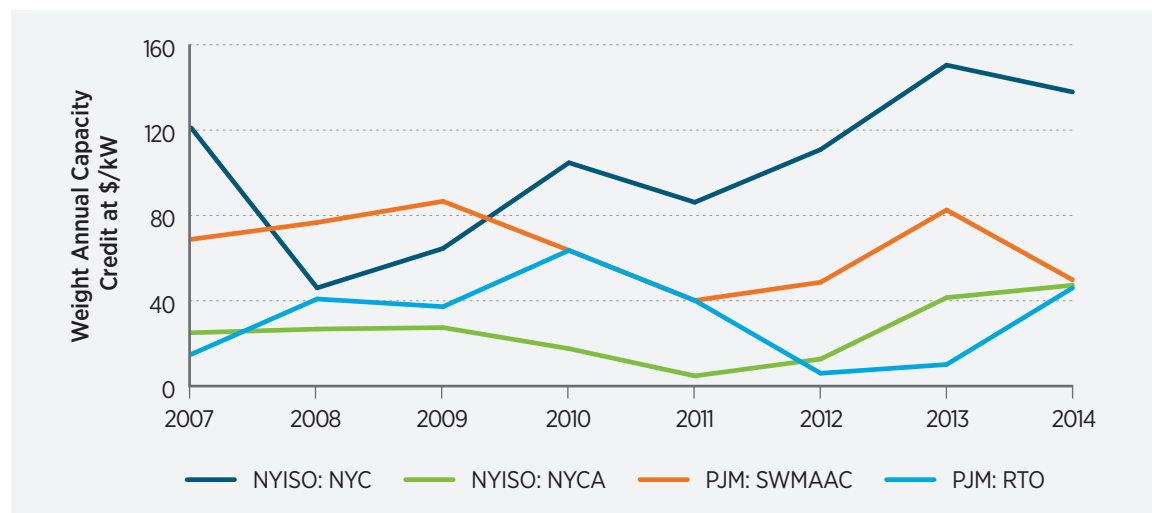

Sources: NYISO 2014 [120]; PJM [119]

**Figure 2-28.** Capacity market clearing prices for four selected markets, annualized 2007–2014

avoid overcommitting. The revenue available from capacity markets supplements that from energy and ancillary service markets, with high capacity prices found in transmission-constrained markets, such as certain zones in New York ISO and PJM (Figure 2-28).

While compensation values can reach or exceed \$100/kW per year, the value of capacity markets is volatile and uncertain on a year-to-year basis (Figure 2-28). The volatility illustrated in Figure 2-28—combined with the lead times necessary to plan, obtain approval for, and build hydropower facilities—can hinder the use of capacity market revenue to justify or source funding for capital expenditures. Long-term bilateral contracting with a utility could make the capital outlay for a facility more attractive, but also suffers from issues related to the long lead times because the timing of project completion may extend beyond utility planning horizons.

Experiences in 2014 with gas supply shortages during record cold events in Midwest [121] and northern markets [122] have motivated modifications to capacity markets for transmission authorities to more heavily penalize underperformance (i.e., not meeting capacity commitments) and ensure supply adequacy, such as the recent revision of PJM’s capacity market mechanisms [123].

Within the U.S. competitive markets, the Southwest Power Pool, CAISO, and ERCOT do not maintain centralized forward markets for ensuring future resource

adequacy. CAISO ensures resource adequacy through regulatory mandates from the California Public Utilities Commission to California’s load-serving entities. Utilities bilaterally procure capacity, and CAISO retains the authority to procure backstop capacity if needed. ERCOT does not have an equivalent forward capacity procurement construct and instead relies on high (\$9,000/MWh) scarcity pricing caps to incent resource adequacy through energy market price signals [124]. In the absence of a capacity market, scarcity prices are much higher than day-to-day prices in day-ahead markets, so that generators are adequately rewarded during times of critically high demand. For context, the average weighted price at the ERCOT North 345KV Peak price hub was \$41.56/MWh [125].

**Challenges and Constraints.** While ISO/RTO markets attempt to provide the structures and mechanisms by which energy generators are rewarded for contributions to the power system, the full accounting, optimization, and compensation for hydropower generation and ancillary services is difficult. In particular, the value (and accompanying opportunity cost) of bidding and deploying hydropower into a market has inter-temporal and non-market environmental and recreational considerations that complicate estimating the true “value” of the water used to generate power. Some attempts to remedy this concern exist; for example, PJM calculates hydropower lost opportunity costs on an inter-temporal basis when compensating

the provision of frequency regulation. The complexities associated with explicitly co-optimizing hydropower generation, ancillary service provision, and environmental benefits, however, is an active field of research within hydropower operations [126, 127].

Co-optimization is acute for PSH and hydropower facilities with reservoir storage that requires long-term resource optimization to maximize the value and use of water in the power system. PSH facilities can be challenged in the day-ahead bidding process as separate bids must be placed for generation and pumping—resulting in financial penalties if pumping and generating bids are not cleared in such a way as to allow for the planned operations. This and other PSH-specific market issues are discussed in Section 2.7.

An additional challenge arises in the coordination among multiple owners on hydrologically interconnected (cascaded) river systems. This coordination becomes even more difficult in a market context. In non-market regions, coordination is possible through an apportionment of the benefits of coordination, such as that which occurs as part of the Mid-Columbia Hourly Coordinating Agreement.<sup>42</sup> In a hydropower-dominant and coordinated system, the addition of a market construct—such as potential regional energy imbalance or economic dispatch markets being investigated by the California ISO and the Northwest Power Pool—would need to be designed and managed to ensure that hydropower operations intended to optimize all water uses are not seen as anti-competitive, and that the flexibility from hydropower resources is not used by market participants without compensation.

**Unvalued and Undervalued Services.** In addition to hydropower assets not being optimally used or valued in organized wholesale markets, not all benefits provided by hydropower facilities are readily quantifiable or easily attributable to hydropower in a market framework. In some cases, market rules undervalue operational flexibility in general—e.g., with the exception of New York ISO, Southwest Power Pool, and CAISO, real-time markets are settled on an

average hourly basis. Fast response resources such as hydropower and PSH, however, have the ability to follow 5-minute price deviations in real-time markets; settling on this real-time basis would more accurately value this capability by tying compensation to prices in the 5-minute interval instead of an hourly average. Markets are trending towards faster settlements. ISO New England anticipates moving to 5-minute settlements in 2016, and MISO is working to implement sub-hourly settlements. Additionally, FERC has recognized and is seeking to reform the mismatch between dispatch and settlement timeframes [128].

It's possible that no value or inadequate value may be placed on some services, such as those provided by hydropower generators with characteristics that allow for rapid and precise responses to instability in the grid. Large hydropower generating facilities with storage and fast ramping ability can react quickly to system disturbances. One example is the participation of some facilities in grid operator Special Protection Schemes and Remedial Actions Schemes. Under these Schemes, pivotal large generators can be dropped from the system to relieve emergent transmission congestion and reliability issues. This capability defers or obviates costly system upgrades, such as transmission expansion, but this value may not be captured by the participating facilities [129].

Hydropower is also one of the major sources of power system inertia and a key provider of primary frequency response, potentially supplying a majority of primary response in the Western Electricity Coordinating Council [130]<sup>43</sup>—yet there is no direct market compensation mechanism for either function. In that sense, existing competitive market structures have evolved around some elements of stability in the power system that hydropower and other technologies provide, and have started to respond with market changes that reward stabilizing performance. Examples of this include “Pay for Performance” regulation services, and evolving capacity and black start market designs. Revisions to address primary frequency response may be possible in the future, as reflected by interest expressed by FERC [131].

42. The Mid-Columbia Hourly Coordinating Agreement is a management program for the dams of the Columbia River system that seeks to balance usage across the projects in an efficient manner. By managing this coordination on an hourly basis, the water is used more effectively across the regional portfolio than longer timeframes would allow, helping to smooth out the natural variability in river flow. The seven dams that comprise this system have been coordinating operations since 1973 [132].

43. “Non-market areas” refers to the parts of the United States that do not have large coordinated markets. These non-market areas are outside of RTOs and ISOs (see <http://www.isorto.org/about/default>).

**Emerging Market Issues.** Several national trends are changing the value proposition for hydropower in non-market areas and competitive markets alike; most notably, the increasing penetration of variable renewable energy sources into the power system. While IOUs and generators in non-market areas are generally better equipped to optimize system operations, their strategies for integrating variable renewables are still subject to regulatory scrutiny. Related experience of BPA is discussed in this chapter in context of integrating renewables with federal hydropower. Wholesale markets, in consultation with market participants, react to the new operating realities imposed by variable renewables by developing appropriate market products and structures to maintain cost-effective grid stability.

High levels of renewables can affect traditional wholesale market values, particularly energy prices, as well as create increasing needs for fast response and flexible resources [133]. Periods of renewable energy oversupply have forced localized prices into negative territory [134]. When this occurs, hydropower projects may be forced to spill water, which goes unused for generation to avoid negative prices (vs. generating power with that water)—or, in cases where flows must be directed through turbines to meet mandated environmental goals such as water temperature or dissolved gas concentration targets, hydropower generators are forced to operate at a loss.

With RPS goals of 33% of generation from renewables by 2020 and 50% by 2030, California is one of the first markets in the United States that is forced to respond to increased levels of variable generation resources with year-over-year increases in negative prices caused by high amounts of non-dispatchable solar and wind generation [135]. Quarterly reports from CAISO demonstrate a new paradigm in energy markets, in which negative prices occur during daytime hours when the sun is shining but mild weather keeps load levels low. This creates the need to ramp generation quickly as the sun sets and peak loads are reached in the evening [136].

In the Midwest, high (and increasing) levels of wind supply within MISO's footprint have led to a series of reforms to address the economic and reliability impacts. Transmission expansion and a move to a market-based economic wind curtailment mechanism (the Dispatchable Intermittent Resource protocol) have held levels of wind curtailment steady [137]. Additional storage and fast-response capability (such as that provided from hydropower) could reduce further the cost of integrating wind. To this end, Manitoba Hydro and the MISO have been exploring the potential for enhanced market integration to use Manitoba's cascaded hydropower system as a “battery” to absorb this excess wind power [89]. This created a new market mechanism in 2015 [138].<sup>44</sup>

With growing amounts of bulk energy provided by renewables, electricity markets—including existing ISO/RTO footprints and proposed new mechanisms such as Energy Imbalance Markets in the West—will continue to evolve and expand, both in terms of physical footprint and in the suite of market products created to deal with changing grid conditions. In light of these new realities, the economic and grid services value of hydropower and other generating assets will be increasingly tied to how flexible they are in responding to variability by ramping capacity up or down quickly.<sup>45</sup>

### **Federal Hydropower**

Federal hydropower is unique in terms of the purpose of the fleet and the requirements under which its power must be sold. Reclamation (14,112 MW; 18% of U.S. capacity), the Corps (20,959 MW, 26%), and TVA (3,619 MW; 5%) comprise a combined 49% of the U.S. hydropower fleet [2], and this ability to capture value is a core determinant of how this near-majority of U.S. hydropower invests and optimizes its power operations.

**Corps and Reclamation Funding Context.** By law, generation from the federal fleet is sold at cost by the respective Power Marketing Administration with first right of refusal of that power given to public power entities, including municipal utilities, public utility districts, and electric cooperatives. Electricity generated

44. Specifically, MISO added bilateral price-sensitive exports to its External Asynchronous Resource structure in March 2015.

45. Structural changes in California to procure flexible resources include flexible ramping constraints in CAISO's real-time market process (flexible resources are compensated for their additional opportunity costs), an additional flexible capacity resource adequacy requirement for load-serving entities [139], and the planned development of a formal market product to procure flexible ramping capabilities in real time [140].



by Corps- and Reclamation-owned hydropower facilities is sold by the PMAs, which market power in excess of project needs to outside customers.<sup>46</sup>

Different PMAs and regions within each PMA offer different products to customers. Most production is marketed through 10–20 year contracts signed with the preference customers.<sup>47</sup> At some PMAs, power in excess of those long-term contracts can be sold in bilateral arrangements with other interested third parties, or bid directly into ISO markets. For most PMAs, revenues from these sales are generally remanded to the U.S. Treasury to cover O&M and service the debt and interest from the construction of the hydropower facilities, and for an allocation of the multi-purpose costs. From the perspective of value capture, this creates an indirect flow of funding back to the generating assets. Reinvestment of the value that hydropower generates through the PMAs must come through the O&M and capital funding that the Corps and Reclamation receive as appropriated by Congress in any given year.

This funding context has led to a situation in which monetary flows to the asset owners and operators do not reflect the market value of their power system operations—or even cover the costs of modernization and general maintenance. For the Corps in particular, production from its facilities is sold by the PMAs for approximately \$3 billion–\$4 billion in annual revenues from at-cost sales, but, in 2010, for example, only \$230 million total was appropriated and allocated to O&M and capital expenditures.<sup>48</sup> Of this, only \$30 million could be used for major equipment replacement and upgrades. The aggregate impact of this limited funding has led to a steady decline in the performance and availability of the Corps fleet across all divisions [141].

However, PMAs do have some additional funding mechanisms to supplement O&M and capital appropriations to the federal owners.<sup>49</sup> The Water Resources Development Act of 2000 allows direct customer funding agreements for all PMAs. While Corps and Reclamation facilities are not valued directly in a

market context, these direct agreements do allow for some additional monetization of the value of federal power operations, at least as determined by the preference customers.

**Alternative Federal Fleet Funding Arrangements.** The value and funding issues faced by the Corps and Reclamation are not new, and it is generally believed that a status quo, flat, or declining Congressional appropriations environment will have deleterious effects on the performance of the federal fleet [143]. Solutions to these issues have been proposed by an array of interested parties, with proposals along a spectrum of market and political philosophies. Proposals include legislative actions that generally maintain market arrangements, such as increasing direct appropriations or altering statutes to allow all PMAs to directly fund O&M, rehabilitations, and modernizations; allowing for public-private partnerships similar in concept to federal Energy Savings Performance Contracts; and even privatizing the federal power generation infrastructure [142].

**TVA as a Federal Utility.** As a federal utility that owns and operates multi-purpose water resource projects in a manner analogous to the Corps and Reclamation, TVA operates under a different mandate and with more financial autonomy than the other federal owners. As a federal utility, TVA's generation and transmission operations are more analogous to a vertically integrated utility in a non-market area. Similar to vertically integrated utilities, TVA internalizes the value of its hydropower system operations, coordinating scheduling and generation to minimize the cost of supplying power from a fleet that includes coal, nuclear, and gas power assets. TVA has received no federal appropriations for its power functions since 1959 (appropriations for environmental stewardship and economic development activities stopped in 1999) and the utility generally operates autonomously. It finances itself fully from its power sales and by issuing bonds; however, TVA's borrowing authority is subject to a statutory limitation of \$30 billion.

46. Some of the multiple purposes of Corps and Reclamation facilities, such as operation of irrigation infrastructure and navigation locks, require electricity. Only the power remaining after accounting for these activities is marketed by the PMAs.

47. The degree of certainty regarding the volume and timing of generation under these contracts varies, including being marketed “as available” (Western Area Power Administration’s Central Valley Project), in “slices” of annual generation (one Bonneville Power Administration product), or on a purely firm basis (Southeastern Power Administration).

48. As such, hydropower is fourth in priority at the Corps—owner and operator of 26% of the U.S. hydropower fleet—with recreation and behind navigation, flood control, and ecosystem restoration) [141].

49. BPA retains its revenues and has the authority to fund capital improvements for the hydroelectric projects for which it markets power. BPA also has Direct Service Industry customers who have preference to federal generation at an established rate which is above their Tier 1 rate.

While TVA is better positioned than other PMAs to value and optimize the use of its hydropower assets, it has historically been subject to strategic reviews of its continued operation as a federal entity [144]. The 2014 review [145] found that TVA was operating successfully under a status quo arrangement, and recommended against divestiture of TVA assets by the federal government.

**Multi-Purpose Role of Federal Hydropower.** The multi-purpose nature of federal hydropower results in a complex set of operating considerations (Figure 2-29). These bounds affect both operational flexibility

and the extent to which these facilities can maximize the power system value of their power production function. Even though non-federal projects also have to comply with licensing conditions to protect fish and wildlife or to coexist with other purposes, competition from other uses can be greater for federal facilities. Power production at federal facilities is often viewed as a “by-product” of other project functions. This dichotomy is due to the origin of federal hydropower capabilities as components of integrated water resource infrastructure. For the Corps, the primary functions of dams have been inland navigation and

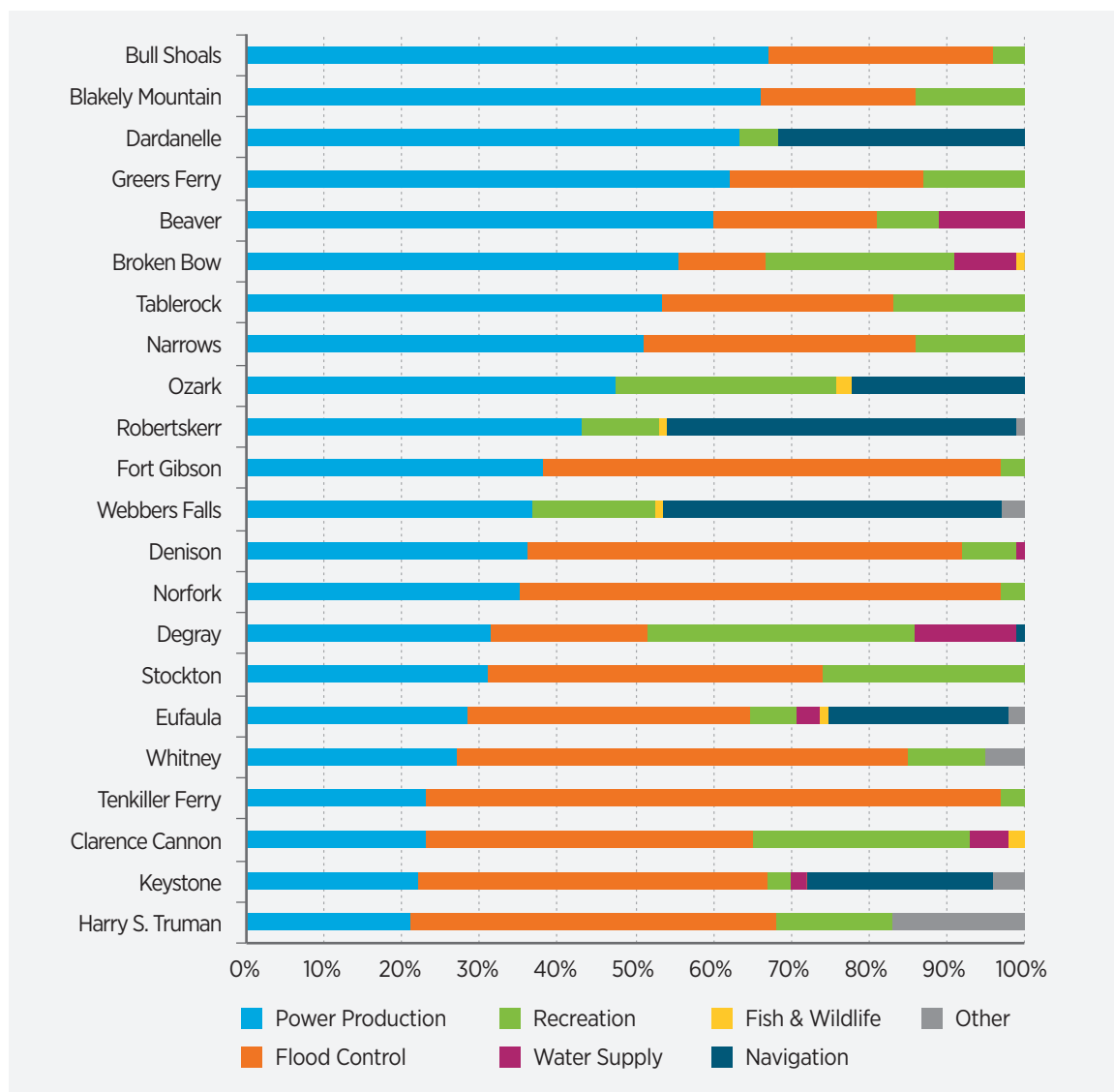

Source: Southwestern Power Administration, 2009

**Figure 2-29.** Allocation of capital costs for multi-purpose Corps projects based on Congressionally authorized use within the Southwestern Power Administration

flood control, while for Reclamation, dams have been used for irrigation and water supply.

Figure 2-29 illustrates this multi-purpose use by showing the portions of project capital costs assigned to the Corps facilities from which Southwestern Power Administration markets power. While in most cases the hydropower purpose was not assigned a majority of the original project cost allocation, it is often allocated the largest or second largest share of the cost.

The federal hydropower purpose has full repayment responsibility, through PMA rates, for 100% of the hydropower costs, including the original capital investment allocation and any reinvestment in the project, as well as for a hydropower assigned percentage of joint-use costs specific to each project. This includes interest on all of the investment costs. Additionally, the PMA rates that provide for repayment include annual O&M costs that recover 100% of the hydropower O&M costs and the hydropower assigned percentage of joint-use O&M costs specific to each project. Other purposes do not have repayment responsibility and in some instances, federal hydropower is footing the bill, directly and indirectly, for some of these other purposes. Therefore, the value or revenue fractions of the various purposes do not necessarily correlate with the cost fractions. For instance, in many Reclamation projects, power production is authorized to repay other purposes (e.g., irrigation) and has been essential to overall project repayment. This pattern is also clear in the Southwestern Power Administration's allocations, although the Corps receives appropriations for flood control and navigation. In the case of BPA-marketed power, 30% of preference customer rates are composed of charges associated with environmental mitigation and stewardship of fish and wildlife [142].

#### **Emerging Issues—Renewables on PMA Systems.**

Increased penetration of variable generation in the western portion of the United States may pose challenges for PMAs. Maintaining system balance while accommodating large amounts of variable output requires keeping more reserves with various response times (regulating reserves, following reserves, imbalance reserves). Rather than rolling the additional cost of maintaining reserves into customer rates, PMAs translate the expenses into integration charges for third-party variable renewable generators connected to the PMA transmission systems.

In 2013, wind and solar generation represented 24% of total installed capacity in BPA service territory. The level of wind penetration in the BPA system forces grid operators to manage seasonal generation oversupply. During spring months with high river flows due to snowmelt, the environmental requirements governing operations along the Federal Columbia River Power System often require that hydropower managers address high dissolved gas concentrations produced by unforced spill by operating at maximum hydraulic capacity to pass as much water through turbines as possible. High hydropower generation, coupled with low loads and high wind during the spring months, forces Federal Columbia River Power System operators to take corrective actions, limiting flexibility in an otherwise flexible system. The actions and appropriate compensation in a market context (such as environmental redispatch or wind curtailment) were disputed among PMA customers, BPA, and VG owners. The disputes were settled through a 2014 FERC approval of BPA's proposed Oversupply Management Protocol, which allows BPA to recover costs incurred while managing oversupply issues [123].

Though levels are not comparable to BPA, the Western Area Power Administration is also experiencing an increase of renewable generation on its system. At the Western Area Power Administration's Colorado Missouri Balancing Authority, 9.8% of total generation came from intermittent renewables. To prepare for future required flexibility related to renewable energy generation, the Power Administration has integrated its Upper Great Plains Region into the Southwest Power Pool. This increases access to generating resources that can provide the additional reserves needed.

#### ***Unique U.S. Market Segments***

The value of hydropower is substantially different in the unique markets outside of the continental United States. Alaska and Hawaii are smaller markets in which access to electricity is limited and more costly relative to the continental United States.

In Alaska, the potential for new hydropower development is limited by the market, not the resource; the 4.7 GW potential from previously identified hydropower sites [65] is double the entire state's installed electric generating capacity as of 2014. Alaska is home to three distinct types of power markets, each with their own unique grid issues and relation to hydropower: the Southeastern region; the Railbelt;

and isolated, rural communities.

In the non-remote communities of Alaska's southeastern region, hydropower is the dominant source of electricity, comprising 96% of generation in 2011 [147, 148]. While undeveloped hydropower resources are available, the region's non-isolated local power markets cannot accommodate additional hydropower. Because of this, exploration of hydropower development in the region has focused on the potential to export to British Columbia and the Pacific Northwest. Both of those markets are already served by hydropower projects with similar or lower levelized electricity costs. Developing new hydropower for export would require additional transmission and infrastructure investment, rendering most such projects economically infeasible [149].

The Railbelt is the grid-interconnected region stretching from the Kenai Peninsula to Anchorage, and north to Fairbanks. This region is home to roughly three-quarters of both Alaska's population and its electricity demand. Hydropower is a relatively small contributor (8%) to power supply in the Railbelt. The Railbelt is not an integrated, single energy market similar to traditional utility footprints in the continental United States. It is composed of six electric cooperatives and municipal utilities with relatively weak interconnections, often over single lines between service territories. This limited level of interconnection limits the integration of variable renewables, constrains optimal output from existing hydropower facilities, and prevents centrally coordinating the operation of generating units throughout the Railbelt interconnection [150].

The third Alaska power market comprises rural communities scattered across the state without formal grid access. These communities rely on diesel generators, and maintain low power consumption in order to avoid high prices (\$0.30–\$1.00/kWh in 2011) [148]. For isolated communities (and remote commercial operations, such as mining or fossil fuel extraction), even small, comparably expensive hydropower plants can be a cost-effective alternative to diesel-fired generators. Hydropower development also adds storage capacity for remote locations. This allows for the potential to couple hydropower with renewables to further offset dependence on diesel fuel, which is typically more costly and may need to

be flown in via helicopter.

Hawaii has no single electricity market—each individual island is an independent, stranded market that relies largely on oil imports [151]. Hawaii has an aggressive plan to reduce both its oil dependence and greenhouse gas (GHG) emissions. The state's RPS law, passed in June 2015 (Act 97), requires each electric utility company that sells electricity for consumption in Hawaii to have 100% of net electricity sales come from renewable energy by 2045 [152]. Hawaiian Electric Companies customers who generate solar, wind, hydropower, or biomass energy on their own property, provided the system capacity is 100kW or less, may also be eligible for net energy metering to offset their own use.

### *International Issues*

The value of participation in U.S. electricity markets is not limited to U.S. generation resources; in particular, Canadian hydropower is playing an increasing role in formal U.S. markets along the Northern border. While Canadian utilities already participate in the Western Electricity Coordinating Council, and, by virtue of transmission interconnection, are key partners in NERC reliability standards, evolving market structures and needs within competitive markets may be changing the way in which Canadian hydropower is valued in U.S. markets. The case of increased cooperation in the Midwest between MISO and Manitoba Hydro was discussed previously in the context renewables integration, and additional considerations are at play throughout other U.S. and Canadian markets.

In the Northeast, New York ISO and ISO New England have strong interties to major hydropower producers in Ontario<sup>50</sup> (7 GW of hydropower) and Hydro Quebec (35 GW). Hydro Quebec borders both markets while Ontario is only interconnected into New York ISO. The New England states are considering stronger interties to Canadian hydropower producers in light of gas supply infrastructure concerns and the retirement of major nuclear generators. Expanded access to Canadian hydropower in the Northeast would require strengthening interties (either with new transmission capacity or upgrades) between the two countries. Policy discussions are ongoing with regards to whether large Canadian hydropower should be considered “renewable” for the purposes of state RPS standards.

50. Ontario Power owns 7 GW of hydropower assets, and the power system in Ontario is managed by the Province's Independent Electricity System Operator.



In the Pacific Northwest, the interplay among value, hydropower operations, and power trade with Canada is treated differently. Of particular importance are the governing stipulations of the Columbia River Treaty. Signed in 1961 and implemented in 1964, the Treaty resulted in the cooperative development and operation of the Columbia River Basin to reduce flooding and increase hydropower generation. Under the Treaty, Canada receives half of the downstream power benefits—that is, additional generation in the United States—created by strategic water management at its upstream storage facilities. This provision for the return of power value is known as the “Canadian Entitlement,” and its monetary value has been estimated at between \$200 million and \$350 million per year. The Entitlement is supplied by BPA’s customers and the Mid-Columbia Public Utility Districts, split approximately 73% and 27%, respectively [153]. After September 15, 2024, either country has the option to terminate most of the Treaty provisions, including the Entitlement, by providing a 10-year advance written notice.

The Corps and BPA represent the United States in implementing the Treaty (collectively, the U.S. Entity); Canada is represented by BC Hydro. In 2013, the U.S. Entity filed recommendations to the U.S. State Department about the future of the Treaty [154]. Among these recommendations, they noted that the United States should pursue a rebalancing of the Treaty with respect to the Entitlement. At issue is whether the originally negotiated calculation of downstream power benefits is an accurate reflection of actual benefits to U.S. power customers. There are a number of reasons the existing calculation method is considered inaccurate, but they are all generally the result of power markets and U.S. hydropower operating realities looking much in different in the 21st century than they did—and were forecast to—when the Treaty was originally negotiated in the 1960s. In particular, the existing entitlement calculation is, by law, based on hypothetical optimal generation [155] and ignores changes in Columbia River operations necessitated by environmental regulations and increasing levels of variable generation interconnected into BPA’s transmission system.

A related issue that may be addressed during a renegotiation of the Treaty is the transmission of Entitlement energy over lines running through the heavily-populated Puget Sound area. This has created

transmission congestion events and threatened service reliability, and the U.S. Entity has recommended that the United States should seek a least-cost transmission strategy for any power returned to Canada after 2024, including reconsidering the flexibility of the return.

### 2.3.2 Environmental Markets

As a renewable source of electricity, some hydropower facilities have the opportunity to capture additional monetary value due to the low-carbon attributes of hydropower generation. The eligibility of hydropower to participate in environmental markets, however, varies across the country. Every segment of every market (e.g., state RPS, corporate sustainability initiatives, GHG emissions policies) has differing criteria under which hydropower is considered eligible. There are two types of environmental markets: renewables markets and emissions markets, both of which contain other market segments (Figure 2-30).

#### Renewables Markets

Renewable energy markets are a potential major source of direct monetary value for hydropower proj-

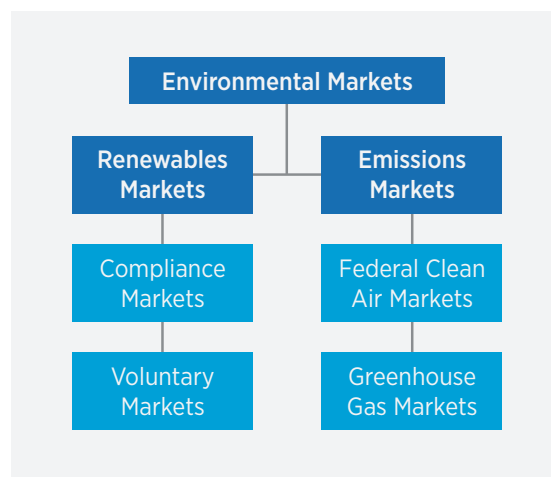

**Figure 2-30.** Hierarchical structure of environmental markets, including renewables markets and emissions markets

ects. These markets capture and reward the renewable elements of electricity production in the form of RECs, which are produced in proportion to generated electricity. The monetization and value of these attributes

(quantified in RECs) are defined on a market-by-market basis. The magnitude of value available to hydropower in a market is contingent on the stringency of a legal requirement (as in compliance markets), the value of sustainability to individual organizations (in the form of voluntary markets), and the eligibility of specific types of hydropower resources to participate.

Compliance markets related to renewable energy typically take the form of procurement requirements placed on utilities or load-serving entities by state-level government mandate. These requirements are reflected in RECs; i.e., entities are mandated to generate (or purchase) a required number of RECs. Twenty-nine U.S. states have compliance renewable energy markets, while another nine states and two territories have voluntary goals, which are not explicitly coupled to market structures [34]. The value of RECs in compliance markets varies based on renewable resource eligibility, resource availability, and the relative availability of RECs. In primary tiers,<sup>51</sup> it ranges from a low of approximately \$1/MWh in Texas, to \$15/MWh in states served by PJM, and increases to nearly \$60/MWh in ISO New England states<sup>52</sup> [2]. Despite potentially attractive pricing (depending on market conditions), however, hydropower is not uniformly eligible for participation in renewable energy. Typical eligibility requirements placed on hydropower for participation in the most valuable, primary tiers of REC markets include [2]:

- Capacity limitations, with 30–50 MW being the range of common limits.
- Hydropower<sup>53</sup> resource and technology limitations that define or restrict eligibility based on whether the project in question is a new facility, incremental to an existing facility, the addition of power on an existing non-powered dam or conduit, or PSH. A typical restriction in the highest cost REC markets, such as in a state RPS, is that a facility be constructed on an existing dam or conduit, thus excluding development requiring new impoundment structures. Some states have unique RPS provisions with respect to PSH, which must often—but not uniformly—pump from energy generated by RPS-eligible resources in order to qualify for RECs.

- Age, online dates, or vintage, which typically restrict primary tier eligibility for projects constructed after the enactment of an RPS provision. This means the existing hydropower resource base is excluded. Explicit criteria that compare the operational, environmental, and public qualities of a hydropower project to standards that enable the project to be deemed eligible for participation. The most common such standard is the LIHI's certification program [68], used for RPS eligibility purposes in four compliance markets (Pennsylvania, Massachusetts, Oregon, and Delaware). LIHI does not include age or vintage restrictions, but its certifications do need to be renewed every 5–10 years.
- Asset ownership to define RPS eligibility (albeit less frequently). This includes restricting hydropower RECs to facilities owned by municipal or cooperative utilities (Pennsylvania), or legislating special provisions for energy from the federal fleet marketed by the PMAs (Oregon, North Carolina).

The immediate impact of this patchwork of eligibility is to render the RECs from hydropower projects substantially less liquid than those from other renewables, such as wind. This reduces their value overall, as it is more difficult to find off-takers at high value for RECs eligible in only limited markets.

There are varying motivations behind these eligibility restrictions. For example, many criteria with respect to age or vintage are intended to incent the development of new renewable resources or restrict the pool of RECs (by disqualifying existing hydropower) in order to raise the incentive value of RECs. Doing so, however, places existing low-carbon hydropower generation at an economic disadvantage relative to new sources of renewable generation—including, in some cases, new hydropower.

Many of the other eligibility requirements are attempts to limit the participation of hydropower to a subset of projects considered socially or environmentally acceptable by state RPS stakeholders. The potential efficacy of eligibility requirements in achieving these ends, however, varies. Where the use of LIHI certification (for example) as an eligibility

51. RPS resources are often separated into tiers based on their perceived “greenness” or a state’s desire to incentivize development of a specific technology. A typical structure might include primary, secondary, and tertiary tiers of generating assets, with decreasing incentives at each step. If such a tier system exists, the primary tiers typically have the most stringent requirements [2].

52. PJM has partial and complete coverage of Delaware, Illinois, Indiana, Kentucky, Maryland, Michigan, New Jersey, North Carolina, Ohio, Pennsylvania, Tennessee, Virginia, West Virginia and the District of Columbia. ISO New England comprises Maine, Vermont, New Hampshire, Massachusetts, Connecticut, and Rhode Island [156, 157].

53. A number of RPS policies explicitly allow for marine and hydrokinetic technologies such as wave, tidal, and in-stream turbines.

requirement is the *direct* incorporation of environmental and social criteria in determining the types of hydropower which should be allowable under RPS, other eligibility requirements such as size and resource/technology criteria are not necessarily tied to the actual impacts or performance of hydropower projects. The use of such *indirect* criteria creates inconsistencies in how—or doubts as to if—environmental and social aspects of hydropower development and operation are used to determine eligibility for REC markets. In addition to creating the liquidity and value issues discussed previously, the use of such indirect criteria also prevent the financial incentive of REC market eligibility from being a motivator to improve on social and environmental metrics. Where markets valuing these aspects of hydropower directly exist (as in select RPS provisions) they provide clear criteria, price signals, and funding sources that may incent environmental improvements. Where other indirect criteria are used, there can be no incentive for improvement. Ultimately, restrictions on facility size, and resource,<sup>54</sup> and the general restrictions on project age and vintage limit the opportunities to use renewable market price signals to incent a more sustainable breed of hydropower plants.

Another challenge is the ability to enter into long-term contracts with a credit-worthy entity due to the variability and uncertainty of REC markets—a problem that is exacerbated relative to other renewables by the long lead time for hydropower projects. As financing for new construction is often dependent on showing long-term expected revenue, long-term contracts are often vital to getting new projects developed. Some states overcome this challenge by having explicit compliance programs that allow for long-term contracts for new or existing facilities, such as the New York State Energy Authority’s Main Tier Solicitation, or Rhode Island’s Affordable Clean Energy Security Act. “Long-term” is defined by these programs, however, as 10–20 years, which is less than the typical full physical or economic life of hydropower assets. The oldest power plants in operation tend to be hydropower facilities and may continue operating beyond 100 years [158].

Though compliance markets create a legal obligation to purchase RECs, many organizations and individuals opt to purchase renewable (or “green”) power

directly through voluntary markets. Pricing in this market segment is lower than that in compliance markets; voluntary REC prices have traded at less than \$1/MWh [159]. Eligibility criteria similar to those in compliance markets are applied to hydropower in voluntary markets as well.

Of the 24 national retail REC products known variously as tags, credits, certificates, or energy, only seven include hydropower. Hydropower is an eligible technology, however, for the well-known voluntary market REC verification organization, Green-e. Under the Green-e standard, U.S. hydropower is subject to an age/vintage requirement in which only new facilities (defined on a 15-year rolling window) are eligible. They must also meet either the explicit environmental criteria set out by LIHI, or a resource qualification restricting eligibility to powered conduits or canals. Repowered facilities are subject to the additional restriction of a 10-MW capacity cap [160].

Corporations may choose to directly procure renewable energy through the direct contracting or purchase of facilities—one recent example of this in the hydropower industry is Apple’s partnership with Natel Energy to build a small hydropower project in Oregon [161]. More broadly, the U.S. Environmental Protection Agency (EPA) provides guidance on voluntary REC markets as guidance to potential corporate purchasers. Under this guidance, however, hydropower is only loosely defined as typically operated in run-of-river mode and having fewer environmental impacts than large-scale hydropower, while meeting river and ecosystem quality standards [162].

Most end-use electric customers can participate in voluntary markets through “green power purchase” agreements with their electric service provider, which allow customers to pay a premium for electricity generated from renewable sources. More than half of all electricity customers in the United States have direct access to green power pricing [159]. Under these programs, utilities acquire RECs and then make them available to customers through bundled PPAs with renewable projects, or through market or bilateral contracts for unbundled RECs. The role of hydropower in this environment depends on the specific REC products being sought. Hydropower comprised 4% of total green power sales in 2013 [159].

54. Even in the LIHI standards, greenfield development is not allowed, since dams and impoundments associated with a hydropower project must have been constructed prior to 1998. It remains at least conceptually possible, however, that development at new sites could in many ways be more sustainable than some existing projects eligible under existing RPS criteria.

Federal renewable energy procurement presents a unique situation. The federal government is, in aggregate, the largest single buyer in voluntary renewable energy markets. Federal agencies purchased 4.1 million MWh of renewable energy in 2013.<sup>55</sup> Hydropower—much of it from existing facilities—comprised 10% of this amount [159]. Existing hydropower, however, does not count towards the renewable electric energy consumption requirements the federal government must meet under the Energy Policy Act of 2005, as amended (42 U.S.C. § 15852, Pub. L. 109-58). Under this Act, for hydropower, only “new hydroelectric generation capacity achieved from increased efficiency or additions of new capacity at an existing hydroelectric project” counts towards the federal government’s renewable electric energy consumption requirements (42 U.S.C. § 15852, Pub. L. 109-58).

### **Emissions Markets**

In addition to direct value streams from compliance and voluntary renewable energy markets, the relative value of hydropower is also contingent on how regulations constraining environmental impacts from power plants change the value of fossil fuel generators as well as energy prices more broadly.

Some environmental regulations take explicit market form, such as the EPA’s Cross-State Pollution Rule, which requires reductions in sulfur dioxide (SO<sub>2</sub>) and nitrogen oxide (NO<sub>x</sub>) emissions in the eastern United States. Hydropower’s lack of emissions relative to major SO<sub>2</sub> and NO<sub>x</sub> emitters (such as coal or oil-fired plants) make it a more attractive choice in terms of emissions; however, EPA analysis suggests its Cross-State Pollution Rule has minimal impact on overall electricity prices [163].

One potential source of a shift in the relative value of hydropower assets could come with attempts to regulate the emission of GHG from power generators. No current federal regulation or market exists, but California has established a state-level GHG market linked via a cap-and-trade mechanism to GHG reduction policy in Quebec and Ontario, and a regional market for Northeastern and Mid-Atlantic states (the Regional Greenhouse Gas Initiative) has existed since 2008.

While no federal GHG policy is in effect, EPA’s Clean Power Plan highlights the unique issues for hydropower in potential future GHG markets and

regulations. In particular, the Clean Power Plan illustrates the contrast between hydropower’s capability to meet these goals and how it fares in terms of compliance [164].

For example, under the Clean Power Plan measures, GHG baselines are estimated from emissions in 2012—a year with abnormally high hydropower production in the Northwest due to favorable hydrologic conditions. Hydropower displacement of fossil fuel generation created a very low emission baseline from which the EPA determined interim and final reduction goals [165]. This treatment creates a more stringent target for the affected state, but also potentially higher value for hydropower plants from higher energy prices. Hydropower could also support Clean Power Plan compliance by lowering the cost of integrating variable generation.

While EPA considers new hydropower facilities as possible compliance options, state-level policy would ultimately determine the mechanisms by which targets are met. Under some approaches, the complexity that surrounds hydropower eligibility in state RPSs may come into play in situations where resources determined to be renewable are granted carbon dioxide (CO<sub>2</sub>) offsets [166]. If hydropower is not counted as a comparable compliance resource when compared to other non-hydropower renewables, nuclear, or natural gas, existing hydropower assets and development of incremental and new resources could be at risk.

Under carbon constraints, hydropower’s value relative to GHG-emitting resources can be enhanced, unless emissions targets fail to identify hydropower as a compliance tool. Assurance that hydropower is eligible as a low-carbon option can help ensure that hydropower resources are maintained and enhanced as part of a low-emission future.

### **2.3.3 Project Economics**

The value the owner or developer of a hydropower project places on their facility, and its overall financial viability, is contingent on both investment philosophy and access to financing. The long-term value streams provided by hydropower are thus evaluated differently by different segments of the power industry. These varied investment perspectives combine with market value streams and a variety of federal and state incentives to drive the economics of hydropower projects.

55. This is in contrast to the top single private purchaser in these markets, Intel, with annual purchases of 3.1 MWh in 2013 [159]. In addition to renewable energy purchases, the Corps, Reclamation, and TVA also consume renewable hydropower generation on-site to support the operation of water resource infrastructure, such as pumping water for irrigation and controlling gates on navigation locks.



### **Project Ownership, Project Value, and the Cost of Capital**

Given its long life cycle, hydropower's full value is only captured across its physical life, which often exceeds 50 years. In the most basic terms, owners of hydropower assets with the lowest cost of capital (i.e., lowest discount or interest rate) are able to place higher value on long-term benefits. However, various players in the energy industry maintain their own development and investment philosophies across different timescales, requiring varying returns on investments:

- IPPs, which have accounted for much of new generation development [167] and the majority of renewables development [168], typically seek quick payback projects financed by non-recourse bank debt and high-cost equity. Prior to the recession, projects with longer PPAs were able to find commercial bank terms as long as 15 years, and deals with institutional lenders as long as 19 [169].
- IOUs take a longer term perspective and can internalize the benefits of hydropower to their power systems with lower rates of return than IPPs. This is because IOU projects are corporate-financed, using utility balance sheets with payback guaranteed through the customer rate base [169, 170].
- Public power entities ultimately employ even longer horizons and lower discount rates with which to value hydropower, and can fully finance projects using long-term revenue bonds [170]. Credit ratings for public power entities, including those that own and develop hydropower, are generally competitive. The hydropower-backed revenue bonds of the Mid-Columbia public utility districts and the municipal consortium Missouri River Energy Services, which is developing non-powered dams, have been rated as high, investment-grade (Aa3/AA- or above) [171].
- Conceptually, valuation of the federal fleet occurs at the lowest rates, with internal planning discount rates based on the yields of treasury bonds with long-term maturities (fixed at 3.375% for 2015) [172]. In the case of capital expenditures on the federal fleet funded by preference customers, however, such as the Corps Hydropower Modernization Initiative, federal hydropower has been effectively financed

and valued at something more akin to public power rates. Similarly, when exercising its borrowing authority, BPA is rated as well as or better than large hydropower-backed public power entities [173].

The financial structure and valuation timeframe for each owner/developer paradigm is driven not only by investment philosophy (i.e., maximizing returns for IPPs, minimizing cost of service under fair rate of return for IOUs, minimizing cost of service for public power), but also by the available sources of financing for each. The solid investment grade ratings of public power bond issuances can be marketed to a variety of fixed-income institutional investors, such as banks or pension funds, with investment philosophies that align to the long-term value streams of hydropower projects. IOUs can access medium- to long-term financing through stock market equity and corporate bond issuances, while project financing for IPPs must obtain relatively high-cost investors willing to accept higher risks, such as private infusions of equity and non-recourse bank loans.

These disparate valuation and financing perspectives intersect with a core difficulty in hydropower project development—the fact that formal market value streams send price signals that do not align with either the development or operation timeframes for projects. Since 2005, the median hydropower project has taken more than 12 years from inception to commercial operation [2]. In that same timeframe, electricity and REC market prices have vacillated with natural gas prices and varying policies. Many, but not all,<sup>56</sup> centralized markets procure capacity three years in advance, which often may not cover the construction timeframe of a typical hydropower facility. IOU and public power investors, with their ability to internalize hydropower's benefits and finance project development on balance sheet, are better able to justify pursuing hydropower projects. IPP developers, however, must undertake the lengthy and risky portions of the project development process while dependent on equity funding. Conventional debt sources of project finance are typically inaccessible until lenders have adequate certainty in developers having resolved regulatory (e.g., FERC license) and revenue (e.g., PPA, capacity market, REC contract) risks [174].

56. Some markets have extended this timeframe, such as ISO New England's move to a 7-year lock-in period. This change may improve hydro-power financing options in the long term.

Developers of small projects face additional challenges based on the limited scale and relative small dollar value of their projects to potential investors. Large hydropower owners ensure investor interest through bond issues or loan prospects for which smaller projects do not have sufficient leverage. In cases where small projects *are* able to secure the interest of large, conventional financing sources (such as commercial banks), their financing costs are usually higher on a relative basis (per MW) [175]. While all hydropower projects are subjected to rigorous due diligence, the cost of this process is spread across fewer MW for small projects relative to their larger counterparts. This suggests that innovative financing solutions are necessary in the small hydropower market.

One successful approach has been to pool smaller projects together for financing purposes [175]. A greater total investment opportunity will draw more interest and lower the relative transaction costs, while pooling assets in different geographic and hydrologic regions can also lower the risk profile of the project portfolio to investors by diversifying exposure to any single market or abnormal climate pattern. In the limited cases in which developers have had success getting small projects funded, many have done so through funding mechanisms uncommon in energy infrastructure investment. This includes long-term contracting of new hydropower generation by a municipality in exchange for preferential financing. An example of this is Bowersock Mills in Lawrence, Kansas [2].

### ***Federal Incentives and the Impact on Project Financing***

Federal incentive policy has been a driver in hydropower and renewable energy economics, and has governed the manner in which many projects have been financed. While federal renewable energy tax credits have been attributed with helping drive the growth of wind and solar in the United States, the use and utility of incentives for hydropower development has been more varied. Still, nearly all developments of new hydropower facilities have leveraged federal and state incentives to finance development [2].

Similar to other renewables, hydropower has historically been eligible for the Renewable Electricity Production Tax Credit (PTC) and the Business Energy Investment Tax Credit (ITC). Hydropower has been eligible for only half the value of the PTC relative to other renewables, but it does receive full value of the ITC (30%). The use of the PTC and ITC in justifying a project often requires unique financial arrangements if the project developer does not have the tax burden (“tax appetite”) to make use of the full credit. These arrangements, such as partnership flips, sale-leasebacks, and others, generally result in higher financing costs than if the credits could be used internally [176]. For a brief period after the American Recovery and Reinvestment Act of 2009 (ARRA), a shortage of tax equity prompted the extension of a “cash grant” provision to ITC-eligible projects, removing the need for third parties to make use of the credits.<sup>57</sup>

Each incentive measure values different aspects of hydropower’s contribution to the grid. The PTC directly rewards hydropower generation, albeit at half value. The ITC (or cash grant) directly offsets investment; doing so in hydropower projects makes it less costly to build additional capacity that may ultimately be used in reserve or ancillary service roles (neither of which is necessarily incented by the PTC). Despite improving project economics, the PTC, ITC, and cash grant carried implicit eligibility criteria similar to many state RPS provisions; eligibility for the federal PTC and ITC is also restricted to upgrades at existing facilities and the powering of existing water resource infrastructure. Projects on undeveloped stream reaches are not eligible.

Incentives based on tax credits can help spur private development, but may be less effective for hydropower than other renewable energy industries on two fronts. First, the use of tax credits to improve project economics requires tax equity investors, who are generally focused on the short-term and more costly to secure. This locks out long-term, low-cost financing from institutional investors who lack sufficient tax

57. ARRA temporarily offered grants instead of tax credits due to a shortage of market appetite for equity following the economic downturn, and the resulting immediate impact on tax equity investing institutions [177].

burden and offer traditional debt products [176, 178]. Both of these investment forms typically require a long-term contract, spanning several decades, for the private development. The contract's length acts to reassure the investor that they will be getting their desired return in a consistent, predictable manner. Second, the PTC and ITC are ineffective mechanisms for facilitating increased generation from the public fleet because these incentives are tax-based, and the federal fleet does not pay taxes [179]. This is important considering that 73% of all existing hydropower capacity is owned by public entities [2].

Some non-tax-based incentives exist, such as payments from Section 242 of the Energy Policy Act of 2005 (42 U.S.C. § 15881),<sup>58</sup> which established a production-based incentive for hydropower plants built on existing dams and conduits. However, the magnitude of incentives available under Section 242 is considerably lower than that from the PTC and ITC. Payments are capped at \$750,000/year for an individual project, and annual funding has been inconsistent. Although the program was part of the Energy Policy Act of 2005, Congress only appropriated funds to the program in 2014, 2015, and 2016. Authorization for the program ends in fiscal year 2025. An additional program under Section 243 of the Energy Policy Act of 2005 provides for payments to incentivize efficiency increases at existing facilities, but this program has never been funded. Given the long lead times of hydropower development, incentives contingent on year-to-year funding such as the Section 242 payment or year-to-year eligibility extensions such as the PTC and ITC are not certain to be available by the time developers will be seeking to finance project construction, which introduces an element of risk.

Policy mechanisms in the form of bond subsidies offer support to non-federal public entities developing and expanding hydropower projects. These have included Clean Renewable Energy Bonds, ARRA-funded Build America Bonds, and Qualified Energy Conservation Bonds, among others. Eligibility for each mechanism and their precise nature varies, but these bond incentives generally allow public entities to finance hydropower and other qualifying projects at low rates

using to federal payment of tax credits to investors, or cash payments to the issuing entity. Hydropower projects were eligible and received 24% of the 2009 Clean Renewable Energy Bond allocation of \$2.2 billion [180], and Clean Renewable Energy Bonds and Build America Bonds have been used to finance some of the largest hydropower facilities under development. The most prominent example is the funding of American Municipal Power's 208 MW of Ohio River non-powered dam projects; the utility funded more than \$1.7 billion of its \$2 billion expenditures through the issuance of Build America Bonds and Clean Renewable Energy Bonds [182]. In general, Build America Bonds lowered the cost of municipal borrowing by an average of 54 basis points [183].

Bond incentives to public entities have also resulted in unique financing arrangements for small private developers. For example, the city of Lawrence, Kansas, issued a series of industrial revenue bonds to finance an expansion to the Bowersock Mills & Power Company hydropower project, in conjunction with a long-term PPA for project power through the municipal power company [184]. The entire \$23.5 million was funded through different tax-advantaged bonds, with \$8.7 million coming from the municipality's allotment of Qualified Energy Conservation Bonds [185]. This sale-leaseback measure [184] is similar in concept to the sale-leaseback arrangements made for tax equity investors to use the ITC. In this case, the city actually owns the project, but immediately leased it back to the developers. Municipal ownership facilitated availability of a more attractive financing package.

Federal loan guarantees may also play a role in securing low-cost financing for hydropower projects. In 2014, DOE announced that up to \$4 billion would be available for its Section 1703 loan guarantee program. Eligible projects include the use of innovative technologies<sup>59</sup> at existing non-powered dams, and the addition of variable speed pump turbines into existing hydropower facilities [186]. Other federal loan programs have also been available for hydropower, such as the U.S. Department of Agriculture's Rural Energy for America Program.

58. Unlike the PTC and ITC, the Section 242 incentive is a direct payment for production and not a tax credit. Congress allocated funding for this incentive for the first time in 2014, with \$3.6 million distributed among qualified applicants, based on their 2013 energy production [181].

59. For a technology to meet the DOE Loan Guarantee Program's threshold for being innovative, it must be in commercial operation and at fewer than three facilities in the United States.

### *Additional Incentives at the State Level*

Some states may offer additional incentives with relevance to hydropower. Some of these incentives are tax breaks and financing incentives similar to their federal counterparts, while others provide direct financial assistance. State-level incentives typically take the form of grants, tax credits, or low-interest loans. One example was Oregon's now-expired Business Energy Tax Credit, which was nonrefundable and could be applied against personal or corporate taxes [187]. While the Business Energy Tax Credit was primarily a tax credit, public power entities made use of it by passing the credit to a third party as a payment [187]. The Business Energy Tax Credit was partially responsible for a number of irrigation canal hydropower installations [188].

In addition to supplementing revenue or lowering financing costs, programs at the state level may seek to reduce costs by addressing regulatory barriers and financial risks that inhibit development, particularly for small projects. In 2010, the state of Colorado and FERC signed a memorandum of understanding to streamline the permitting process for small hydropower projects. Under the program, Colorado pre-screened qualifying, low-impact hydropower projects under 5 MW. For pre-screened projects, FERC waived the first and second stages of consultation otherwise required by 18 CFR sections 4.38(b) and (c) [189]. The state also worked as a permitting hub, providing technical assistance to applicants and channeling permitting requests to the state and federal offices involved in the process [190]. In 2008, Alaska created a renewable energy grant fund to provide assistance to utilities, IPPs, tribal groups, and municipalities for feasibility studies, permitting, and construction of renewable energy facilities, including hydropower. This program has been broadly successful in streamlining hydropower development for eligible projects [191].

### **2.3.4 Trends and Opportunities**

Trends and opportunities in Markets and Projects Economics include:

- Improvement in the valuation and compensation of hydropower in power markets is being examined. Linkage of compensation to prices in the 5-minute interval instead of an hourly average should be considered. Since fast response resources such as hydropower and PSH have the ability to follow 5-minute price deviations in real-time markets, settling on this real-time basis would more accurately value this capability and help realize the full potential value of providing ancillary grid services and essential reliability services within power markets.
- Removal of barriers to the financing of new projects would help advance hydropower. Conducting outreach and education with stakeholders and institutional investors can improve access to financing, which is needed to advance hydropower, especially small hydropower.
- Improvement in understanding of and hydropower's participation in renewable and clean energy markets is being examined. An example is consideration of approaches to reduce the patchwork eligibility framework for RECs, while respecting state-specific concerns and needs.
- Improved consistency in how sustainable aspects of hydropower development and operation are incorporated and ultimately valued in the REC market may decrease the variability and uncertainty of REC markets, facilitating entry into long-term contracts. This will help efforts to increase acceptance of hydropower as a renewable energy source.



## 2.4 Hydropower Development

The main opportunities for growth in hydropower are refurbishing the existing fleet, adding generation facilities to NPDs and existing water resources infrastructure (primarily irrigation canals or conduits), NSD, and PSH.<sup>60</sup> Each opportunity area has unique elements, drivers, and challenges to developing additional hydropower capacity. For example, development of hydropower on free-running streams

### Highlights:

- Resources are available to support growth of hydropower as an economically competitive source of low-carbon renewable energy.
- Improved communication and collaboration during the hydropower planning process could expedite the regulatory process and help achieve desired outcomes for all parties.
- In the context of a multi-use, multi-value system of users and stakeholders, hydropower development should incorporate environmental protection measures and sustainability principles in balancing energy needs and water resources.

will require new approaches and involve a broad spectrum of stakeholders. This section provides an overview of hydropower development and includes an explanation of the context within which development occurs. The section closes with suggestions to improve the hydropower development process to the benefit of all stakeholders.

### 2.4.1 Overview of Development

U.S. hydropower is primed to increase its role in the future of low-carbon electricity generation. Industrialization, economic development, and wartime manufacturing needs drove the development of

much of the existing hydropower fleet. This laid the foundation for the growth of hydropower as a key-stone of the electrical grid in many regions and the nation's largest source of renewable energy, delivering about 65% of total renewable generation from 2004 through 2013 [192]. Future growth will be driven by an evolving set of needs and requirements, such as reducing carbon emissions, achieving reliable operation, and stabilizing an electric grid that is subject to new demands. The technology to generate low-carbon, renewable hydropower improves with time, as does understanding of how hydropower development interacts with the social and environmental values of a community. Developers seek to create value through hydropower projects that are viable to build within the regulatory, environmental, social, and economic frameworks that apply at the time development occurs and that will remain viable to operate into the future.

Given that hydropower development in the United States began more than a century ago, it might be assumed to be a mature technology with little opportunity for growth. This, however, is not the case. There is potential to generate additional electricity at existing dams; at existing non-powered dams, canals, or conduits; and at new sites, using new, low-head technologies. Developing this untapped hydropower potential requires addressing social, environmental, and financial uncertainties to the satisfaction of stakeholders, regulators, and financiers. Although many aspects of development are well defined, such as the FERC licensing process or state Section 401<sup>61</sup> water quality certification (WQC), it can be difficult to predict how much each process may cost, how long it might take, or what operations will ultimately be allowed. Project development involves iteratively resolving uncertainties and finding options that make the project viable.

To increase the likelihood that a project will be successful, a developer must identify whether the project: will produce economic return without detrimental social or environmental effects that cannot be avoided,

60. Development of PSH is covered in Section 2.7.

61. Under the Clean Water Act, an applicant seeking a federal license or permit to conduct any activity that may result in a discharge to waters of the United States must provide the federal agency with a Section 401 certification. The certification is made by an authorized tribe and/or the state in which the discharge originates and requires reasonable assurance that the discharge will comply with applicable provisions of the act, including water quality standards. A state's water quality standards may specify the designated use of a stream or lake (e.g., for water supply or recreation), pollutant limits necessary to protect the designated use, and policies to ensure that existing water uses will not be degraded by pollutant discharges.

minimized or mitigated; can avoid complications that might stall or disrupt the development process or hinder the future operational performance; and that balances stakeholder objectives. Characteristics that drive the viability of a project vary somewhat depending on whether it is proposed by private industry, an IOU, or a municipality. Similarly, the criteria that drive development in one area of the United States might differ from those in another part of the country.

### Primary Phases of Development

The hydropower development process can be organized into seven broad phases, many of which overlap and during which applicable permitting, licensing and environmental review is initiated and pursued:

1. Site Identification (Origination)
2. Pre-Feasibility
3. Feasibility
4. Financing/Contracts
5. Detailed Design
6. Construction
7. Commissioning

In each phase, developers seek to identify unusual obstacles or costs before large capital investments are made. In the origination and pre-feasibility phases, site identification and initial screening occurs as an important first step, since the site must be broadly screened for its technical, environmental, social, political, and financial viability [193]. Figure 2-31 illustrates a typical or representative development process for hydropower, in which feasibility is evaluated more thoroughly before progressing to preliminary design and permitting.

Depending on the project size and capacity, ownership of the project site, and other political, environmental, and social considerations, the developer must determine which licenses and permits will be required. Early consultation with agencies, permitting authorities and stakeholders can increase the efficiency of this process. In general, the development pathways are similar regardless of ownership type. Primary differences between development undertaken by federal owners vs. that of non-federal owners relates to 1) FERC jurisdiction and associated licensing, 2) funding or financing mechanisms that affect cost structures, and 3) market access and revenue streams that affect revenue structures.

Bank Perspective	Main Activities (Developer)
<b>Phase 1</b>	<b>Site Identification/Concept</b>
↓	<ul style="list-style-type: none"> <li>• Identification of potential site(s)</li> <li>• Funding of project development</li> <li>• Development of rough technical concept</li> </ul>
<b>Phase 2</b>	<b>Pre-Feasibility Study</b>
↓	<ul style="list-style-type: none"> <li>• Assessment of different technical options</li> <li>• Approximate costs/benefits</li> <li>• Permitting needs</li> <li>• Market assessment</li> </ul>
<b>Phase 3</b>	<b>Feasibility Study*</b>
↓	<ul style="list-style-type: none"> <li>• First contact with project developer</li> <li>• Technical and financial evaluation of preferred option</li> <li>• Assessment of financing options</li> <li>• Initiation of permitting process</li> </ul>
<b>Phase 4</b>	<b>Financing/Contracts*</b>
↓	<ul style="list-style-type: none"> <li>• Due diligence</li> <li>• Financing concept</li> <li>• Permitting</li> <li>• Contracting strategy</li> <li>• Supplier selection and contract negotiation</li> <li>• Financing of project</li> </ul>
<b>Phase 5</b>	<b>Detailed Design*</b>
↓	<ul style="list-style-type: none"> <li>• Loan agreement</li> <li>• Preparation of detailed design for all relevant lots</li> <li>• Preparation of project implementation schedule</li> <li>• Finalization of permitting process</li> </ul>
<b>Phase 6</b>	<b>Construction*</b>
↓	<ul style="list-style-type: none"> <li>• Independent review of construction</li> <li>• Construction supervision</li> </ul>
<b>Phase 7</b>	<b>Commissioning*</b>
↓	<ul style="list-style-type: none"> <li>• Independent review of commissioning</li> <li>• Performance testing</li> <li>• Preparation of as build design (if required)</li> </ul>

\*Involvement of financing institution begins with Phase 3

Source: International Finance Corporation, 2015 [194]

**Figure 2-31.** Representative project development process for a hydropower project

The Regulatory and Permitting Information Desktop, or RAPID,<sup>62</sup> Toolkit provides regulatory flow charts that provide overviews of the requirements a developer must address, along with links to permit applications, processes, manuals, and related information. Under certain circumstances, exemptions or exclusions from permitting may be possible. Consultation with the agencies and permitting authorities as well as stakeholders is typically done as the licensing and permitting plan is developed and initiated [193].

The final project design phase includes finalizing the FERC licensing process or Lease of Power Privilege Process; the Corps permitting process; securing of a PPA or equivalent revenue stream or power sales agreement, if applicable; financing or rate-making approval; and procuring major equipment. Once these steps are completed and authorizations have been granted, the project can move to construction and commissioning.

### Key Aspects of Development

Hydropower development requires regular examination of the balance between the risks and rewards throughout the development process. That on-going examination is often driven by economic considerations. For IOUs, the forecast project cost must remain competitive to other sources of generation. For municipal and private developers, lenders are interested in understanding the risks at each phase to ensure that financing is commensurate with the demonstrated progress. Key areas of interest can include but may not be limited to:

- **Land (Site Control)**—Are the long-term rights necessary to construct and operate the project available or reasonably obtainable?
- **Permits, Licenses and Environmental Requirements**—Can all material permits and licenses be obtained in a timely manner, or with sufficient certainty to obtain as scheduled? What studies are needed? Can requirements for environmental or resource protection be met within the desired timeline and at an acceptable cost?
- **Stakeholders**—Has, or can, alignment of all critical stakeholders to the project be achieved?
- **Engineering**—Do conceptual, pre-feasibility, and feasibility level engineering and technical assessments yield any fatal flaws? Can firm price, schedule, and contract with equipment suppliers and contractors be achieved?

- **Interconnection/Transmission**—What studies are necessary, what is the certainty of interconnection capacity availability, and what is the risk of applicable transmission upgrade costs? Are interconnect fees prohibitive or are contracts difficult to obtain in a reasonable timeframe?
- **Revenue**—What is the certainty on installed capacity, basis of annual energy generation, and associated revenue stream—e.g., long-term PPA, wholesale markets, changing policies or incentives, and relevant market prices and products?
- **Construction/Major Equipment Procurement**—What is the certainty of construction schedule, cost, and potential for delay, and what is the certainty of equipment supply and performance?
- **O&M and Capital Expenditures**—What is the certainty of O&M costs and major capital expenditures over time?
- **Financial Risk**—How are cost escalation, interest-during-construction, and exchange rates accounted for?
- **Commercial Operations Date Provisions**—What commitments (to host/ISO) are being made with respect to commencement of operation? What is the liability/cost of delaying commencement? Will the project meet deadlines of any incentive programs?

## 2.4.2 Context for Development

As noted earlier, approximately half of the existing hydropower fleet is federally owned (i.e., Reclamation, TVA, and the Corps). Development activities by such federal owners fall outside FERC jurisdiction. Although exemptions have been created for specific situations, most hydropower development will fall within FERC jurisdiction, even when proposed by a private developer at existing federal facilities. One exception would be private development at a federal Reclamation project where the Lease of Power Privilege process would apply. A memorandum of understanding between FERC and Reclamation detailing the circumstances under which each agency has authority can be found in the Federal Register (58 Fed. Reg. 3269, January 8, 1993). An overview and context of hydropower licensing and relicensing processes and regulatory framework are discussed in subsequent sections, and additional detail is available on FERC's website.

62. <http://en.openei.org/wiki/RAPID>

### **Key Laws Governing Hydropower Development**

Under the authority of the FPA (see Table 2-2) as amended, FERC authorizes nonfederal hydropower projects located on navigable waterways or federal lands, or connected to the interstate electric grid, or that use surplus water or water power from a federal dam. FERC comprises up to five Commissioners who are appointed by the President and confirmed by the U.S. Senate. The Commission is supported by a staff of environment, engineering, and legal experts who evaluate hydropower license applications, prepare environmental documents, and make recommendations to the Commission on hydropower licensing matters. The Commission may issue an original license, valid for up to 50 years, for construction, operation, and maintenance of jurisdictional projects. When a license expires, the federal government can take over the project; the Commission can issue a new license (relicense) to either the existing licensee or a new licensee for a period of up to 50 years; or the project can be decommissioned. In certain instances, FERC may exempt a project from the licensing provisions of Part I of the FPA, such that the project is instead subject only to environmental conditions mandated by state and federal fish and wildlife agencies. This means that the project is not subject to the comprehensive development standard of FPA section 10(a)(1) (16 U.S.C. § 803(a)(1)), mandatory conditions under FPA sections 4(e) and 18 (16 U.S.C. §§797(e) and 811), eminent domain authority of FPA section 21 (16 U.S.C. § 814), and other provisions.

FERC's primary authority comes from the FPA, which has been amended over time. The most notable of these amendments was the Electric Consumers Protection Act of 1986, which added the "equal consideration clause" to section 4(e) (16 U.S.C. § 797(e)) and added section 10(j) (16 U.S.C. § 803(j)) giving fish and wildlife agency recommendations greater weight than they had previously been given. In general, implementation of FERC's authority relative to licensing, compliance, and dam safety is shaped by the Commission's regulations (primarily Title 18 of the Code of Federal Regulations) as well as by FERC policy statements, guidance documents, and handbooks available on FERC's website. Statutory change over time has also influenced the FERC licensing process. For example, the Energy Policy Act of 2005 contained key provisions addressing and

shaping the regulatory framework, specifically section 241. This section (1) expedited resolution of mandatory conditions, e.g., fishway prescriptions, including timeframes for resolution; and (2) added new section 33 (16 U.S.C. § 823d) to the FPA, which allows the applicant or another party to a license proceeding to propose an alternative condition to an agency prescription that the agency involved must accept, if it is determined that the alternative provides for adequate protection at a significantly lower cost.

Two bills signed into law in 2013 are specific to small hydropower development. The first of these bills, The Hydropower Regulatory Efficiency Act of 2013, shaped the existing FERC regulatory landscape by (1) exempting certain conduit hydropower facilities from the licensing requirements of the FPA; (2) amending Section 405 of the Public Utility Regulatory Policies Act of 1978 to define "small hydroelectric power projects" as having an installed capacity that does not exceed 10,000 kilowatts; (3) authorizing FERC to extend the term of preliminary permits once, for not more than two additional years beyond the three years previously allowed under Section 5 of the FPA; and (4) directing FERC to investigate the feasibility of a 2-year licensing process for hydropower development at non-powered dams and closed-loop pump storage projects. The second of these bills, the Bureau of Reclamation Small Conduit Hydropower Development and Rural Jobs Act, encourages development of small conduit hydropower at all Reclamation-owned canals, pipelines, aqueducts, and other waterways [195].

FERC's authority is shaped further by several other laws and executive orders, most notably the eight federal laws described subsequently.

**National Environmental Policy Act.** NEPA establishes environmental protection as a major national policy objective. The Act requires all federal agencies to evaluate the environmental impacts of major federal actions, including the permitting of activities affecting the environment. The NEPA process requires the identification and assessment of reasonable alternatives to the proposed action, and federal agencies are to use all practical means to restore and enhance the quality of the environment and to avoid or minimize any possible adverse effects of their actions upon the quality of the environment. FERC adheres to the statutory requirements of NEPA.



**Fish and Wildlife Coordination Act.** The Fish and Wildlife Coordination Act requires federal agencies granting a license or permit for the control, impoundment, or modification of streams and water bodies to first consult with the U.S. Department of the Interior's Fish and Wildlife Service (FWS), the U.S. Department of Commerce's National Marine Fisheries Service (NMFS), and the appropriate state fish and wildlife agencies regarding conservation of these resources. A federal agency licensing a development project related to a water resource is required under the Fish and Wildlife Coordination Act to give full consideration to the recommendations of the FWS, NMFS, and the relevant state fish and wildlife agency on the wildlife-related aspects of such projects. FERC is directed under the Act to not only consult with the FWS, NMFS, and the state agencies, but also to include in each license conditions for the protection, mitigation, and enhancement of fish and wildlife. Those conditions are to be based on recommendations received pursuant to Section 10(j) of the FPA (16 U.S.C. § 803(j)) from the FWS, NMFS, and state fish and wildlife agencies.

**National Historic Preservation Act.** The National Historic Preservation Act requires the federal government to accelerate its own historic preservation programs and to encourage such efforts on state, local, and private levels. Compliance with the NHPA may be coupled with FERC's NEPA process where a federal licensing action affects a historical or cultural resource. FERC is bound in licensing decisions by the provisions of the National Historic Preservation Act, which requires the Commission to take into account the effect of the action on any district, site, building, structure, or object that is included in or eligible for inclusion in the National Register of Historic Places, and to give the Advisory Council on Historic Preservation a reasonable opportunity to comment on a proposed action.

**Endangered Species Act.** The purpose of the ESA is to protect and conserve endangered and threatened species, and to protect the ecosystems upon which those species depend. During the hydropower project licensing process, FERC must consult with FWS or NMFS to determine whether the permitting action is likely to jeopardize the continued existence of any endangered or threatened species or result in critical habitat destruction or adverse modification. Where endangered or threatened species may be present in

the area affected by a hydropower project proposed for licensing, FERC may be required to prepare a biological assessment for the purpose of identifying any endangered or threatened species likely to be affected by licensing. This biological assessment may be undertaken as an integral part of NEPA compliance. Under their implementing regulations, FWS or NMFS must provide a biological opinion to FERC within 135 days of receipt of the biological assessment. FERC's general practice is to refrain from issuing a license until receipt of a biological opinion, and to include a biological opinion's terms and conditions as part of any issued license.

**Clean Water Act.** Under Section 401 of the Clean Water Act (33 U.S.C. § 1341), a FERC license applicant must obtain certification from a state, authorized tribe, or interstate pollution control agency that verifies compliance with the Act. Evidence of a request for water quality certification must be filed with FERC no later than 60 days after the Commission issues a Notice of Ready for Environmental Analysis or as otherwise directed by the Commission. Under the provisions of the Clean Water Act, a state water quality certifying agency must issue a water quality certificate within one year of receipt of the application, although this requirement is routinely extended. FERC is precluded from issuing a license until a water quality certificate is issued or waived (or is deemed waived), and FERC must include the terms and conditions of the water quality certification as part of any issued license. Terms and conditions by FWS and NMFS pertaining to fish passage must be included as part of any license issued.

Amendments to the Clean Water Act in 1972 created the National Pollutant Discharge Elimination System. The system, which is managed by EPA, helps address water pollution by regulating point sources of pollutants into U.S. waterways. A permit issued under the National Pollutant Discharge Elimination System usually allows a facility to discharge a specified amount of a pollutant into a water body, under certain conditions. Although hydropower does not result in such a specific continuous or regular discharge, this program adds extra protection relative to aspects such as lubricants in sealed systems or construction activities. EPA authorizes state, tribal, and territorial governments to execute the national system under individual State Pollutant Discharge Elimination Systems.

**Wild and Scenic Rivers Act.** The Wild and Scenic Rivers Act provides for the protection and preservation of certain rivers and their immediate environments by instituting a National Wild and Scenic Rivers System. Rivers may be included in this system either by an act of Congress or by the Secretary of the Interior, upon application by a state governor. Section 7(a) of the Act (16 U.S.C. § 1278(a)) provides that FERC shall not license the construction of any project on or directly affects any river that is designated as a component of the Wild and Scenic River System. Moreover, all departments and agencies of the United States are precluded from “assist[ing], by loan, grant, license, or otherwise in the construction of any water resources project that would have a direct and adverse effect on the values for which [a component of the Wild and Scenic Rivers System] was established.” Section 7(a) of WSR does provide for licensing of or assistance to developments below or above a designated river if it can be determined the development “will not invade the area or unreasonably diminish the scenic, recreational, and fish and wildlife values” present when the river was designated as part of the System.

**Americans with Disabilities Act.** The Americans with Disabilities Act was created to protect the civil rights of persons with disabilities. The ADA requires public and private entities with public accommodations to ensure accessibility to persons with disabilities. Although FERC does not specifically require ADA-compliant facilities, FERC licensees must consider the disabled when planning recreational facilities, and new recreational facilities and access areas at hydropower projects must comply with the requirements of the ADA.

**Pacific Northwest Power Planning and Conservation Act.** Under Section 4(h) of the Pacific Northwest Power Planning and Conservation Act (or Northwest Power Act) (16 U.S.C. § 839b(h)), the Northwest Power and Conservation Council developed and updates every five years the Columbia River Basin Fish and Wildlife Program to protect, mitigate, and enhance the fish and wildlife resources associated with development and operation of hydropower projects within the Columbia River Basin. Section 4(h) of the Northwest Power Act states that the federal

and state agencies with regulatory responsibilities for such projects should provide equitable treatment for fish and wildlife resources, in addition to other purposes for which hydropower is developed. These agencies must also take into account, to the fullest extent practicable, the Columbia River Basin Fish and Wildlife Program, which directs agencies to consult with federal and state fish and wildlife agencies, appropriate Indian tribes, and the Northwest Power and Conservation Council during the study, design, construction, and operation of any hydropower development in the Basin. Section 12.1A of the Columbia River Basin Fish and Wildlife Program outlines conditions that should be provided for in any original or new license, and designates certain river reaches as protected from development. If the project is not within the Columbia River Basin, Section 12.1A would not apply.

**FERC Licensing Processes.** Per FERC regulations, applicants for licenses may use one of three license processes: integrated, traditional, or alternative. In the Integrated Licensing Process (ILP, which is FERC’s default process), Commission staff involvement begins during the pre-filing consultation process and is sustained throughout the licensing process. The ILP merges pre-filing consultation and the NEPA process, brings finality to pre-filing study disputes, and maximizes the opportunity for federal and state agencies to coordinate their respective processes with the Commission’s licensing process. In the Traditional Licensing Process, FERC conducts scoping after an application is accepted for filing, and there is typically little Commission staff involvement during the pre-filing consultation process prior to when the application is filed. In the Alternative Licensing Process, scoping is done prior to filing the application with FERC, but Commission staff involvement during study plan development and other pre-filing activities is advisory in nature. The Alternative Licensing Process is flexible and collaborative, but lacks the scheduling structure and consistent Commission staff assistance offered by the ILP. The highlights of FERC’s three processes are summarized in Table 2-4, followed by a flowchart depicting the key aspects of FERC’s default ILP (Figures 2-32a and 2-32b).

**Table 2-4.** Comparison of Attributes of the Three Hydropower Licensing Processes of the Federal Energy Regulatory Commission

	<b>Traditional Licensing Process (TLP)</b>	<b>Alternative Licensing Process (ALP)</b>	<b>Integrated Licensing Process (ILP)</b>
<b>Consultation with Resource Agencies and Indian Tribes</b>	<ul style="list-style-type: none"> <li>Paper driven</li> </ul>	<ul style="list-style-type: none"> <li>Collaborative</li> </ul>	<ul style="list-style-type: none"> <li>Integrated</li> </ul>
<b>Deadlines</b>	<ul style="list-style-type: none"> <li>Pre-filing—some deadlines for participants</li> <li>Post-filing—defined deadlines for participants</li> </ul>	<ul style="list-style-type: none"> <li>Pre-filing—deadlines defined by collaborative group</li> <li>Post-filing—defined deadlines for participants</li> </ul>	<ul style="list-style-type: none"> <li>Defined deadlines for all participants throughout the process, including FERC</li> </ul>
<b>Study Plan Development</b>	<ul style="list-style-type: none"> <li>No FERC involvement</li> <li>Developed by an applicant based on early agency, tribal, and public recommendations</li> </ul>	<ul style="list-style-type: none"> <li>FERC staff advisory assistance</li> <li>Developed by collaborative group</li> </ul>	<ul style="list-style-type: none"> <li>Plan approved by FERC</li> <li>Developed through study plan meetings with FERC staff involvement</li> </ul>
<b>Study Dispute Resolution</b>	<ul style="list-style-type: none"> <li>OEP Director opinion advisory</li> </ul>	<ul style="list-style-type: none"> <li>OEP Director opinion advisory</li> </ul>	<ul style="list-style-type: none"> <li>Informal dispute resolution available to all participants</li> <li>Formal dispute resolution available to agencies w/mandatory conditioning authority</li> <li>OEP Director opinion binding on applicant</li> </ul>
<b>Application</b>	<ul style="list-style-type: none"> <li>Draft and final application include Exhibit E</li> </ul>	<ul style="list-style-type: none"> <li>Draft and final application include applicant-prepared EA or 3rd party EIS</li> </ul>	<ul style="list-style-type: none"> <li>Preliminary licensing proposal (or draft application) and final application include Exhibit E that has form and contents of an EA</li> </ul>
<b>Additional Information Requests</b>	<ul style="list-style-type: none"> <li>Available to participants after filing of application</li> </ul>	<ul style="list-style-type: none"> <li>Available to participants primarily before filing of application</li> <li>Post-filing requests available but should be limited due to collaborative approach</li> </ul>	<ul style="list-style-type: none"> <li>Available to participants before filing of application</li> <li>No formal avenue to request additional info after application filed</li> </ul>
<b>Timing of Resource Agency Terms and Conditions</b>	<ul style="list-style-type: none"> <li>Terms and conditions filed 60 days after REA notice</li> <li>Schedule for filing final terms and conditions permitted</li> </ul>	<ul style="list-style-type: none"> <li>Terms and conditions filed 60 days after REA notice</li> <li>Schedule for filing final terms and conditions permitted</li> </ul>	<ul style="list-style-type: none"> <li>Terms and conditions filed 60 days after REA notice</li> <li>Modified terms and conditions 60 days after comments on the single EA or draft NEPA document</li> </ul>

Source: Kao 2014)

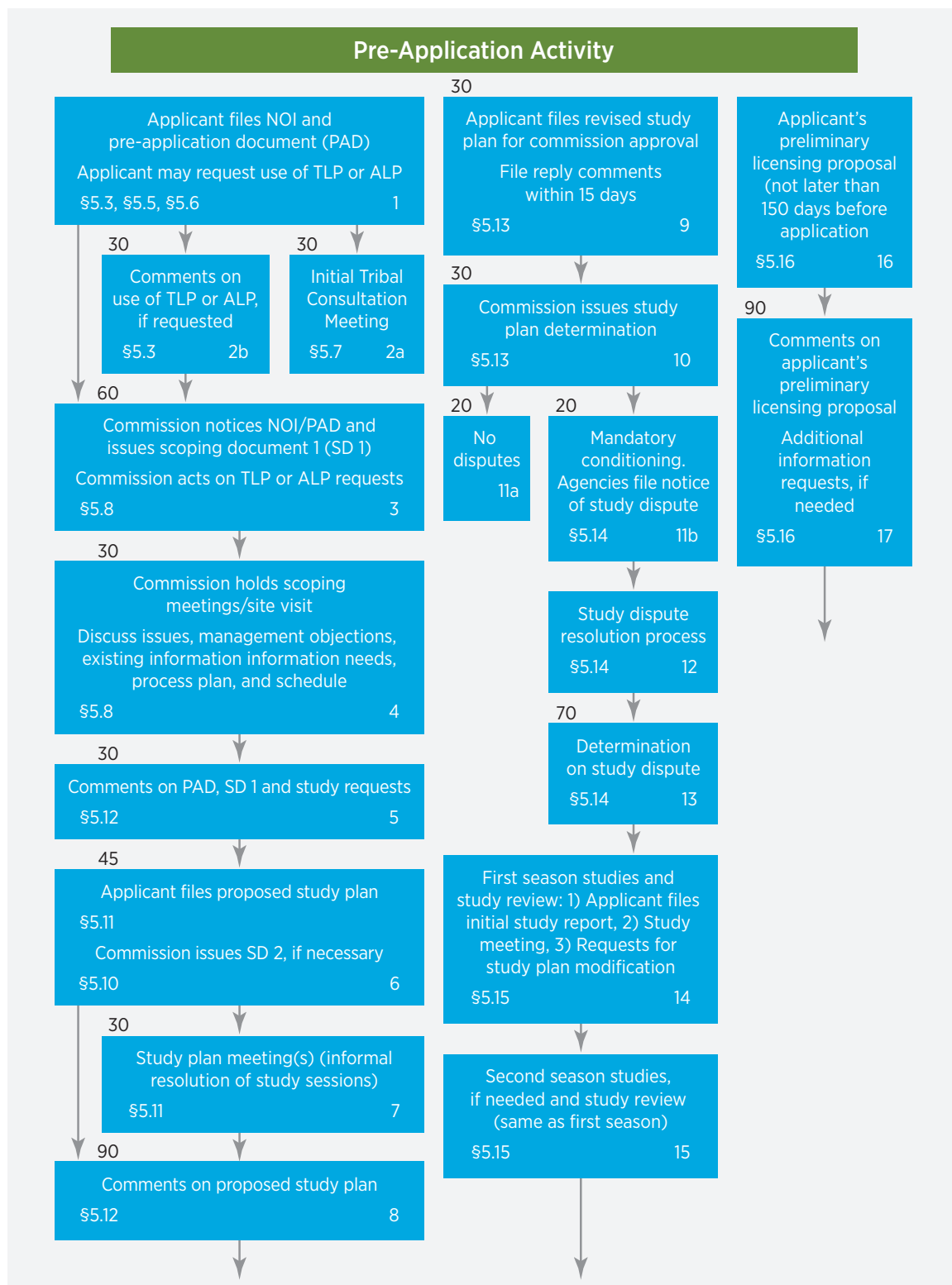

Source: FERC [196]

**Figure 2-32a.** Flow diagram for the Federal Energy Regulatory Commission's Integrated Licensing Process



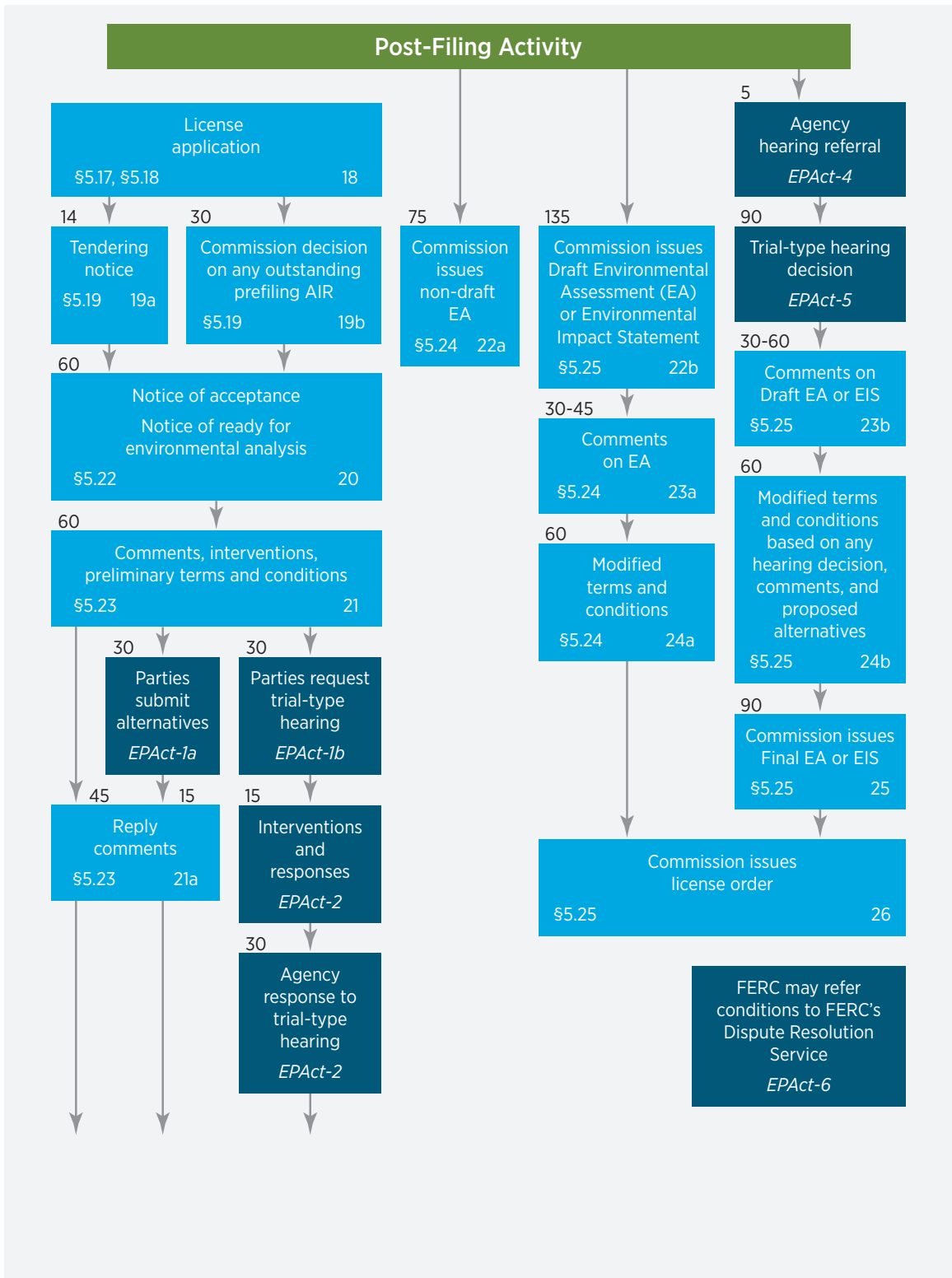

Source: FERC [196]

**Figure 2-32b.** Flow diagram for the Federal Energy Regulatory Commission's Integrated Licensing Process

### The Timing of Development

Hydropower development activities could accelerate if the scope of compliance requirements and timeline of the licensing and permitting processes were more predictable for developers, thereby reducing uncertainty in the development process. Even if requirements remained the same, decreasing the costs or time to commercial operation would increase the rate of growth in installed capacity, and decreasing uncertainty would make it easier to identify which potential projects would be viable. Accelerated

development processes have been proposed in which all areas of concern can be addressed in a predictable timeframe. Figure 2-33 illustrates an example of a proposed “accelerated licensing and permitting” approach, in this case for NPD development at a federal facility. The goal of this approach is to obtain a FERC license in three-and-a-half years and achieve operation of the project in as few as five years after the FERC license is issued [197]. This timeline illustrates the complexity and interdependence of the development process; and, even when “accelerated,”

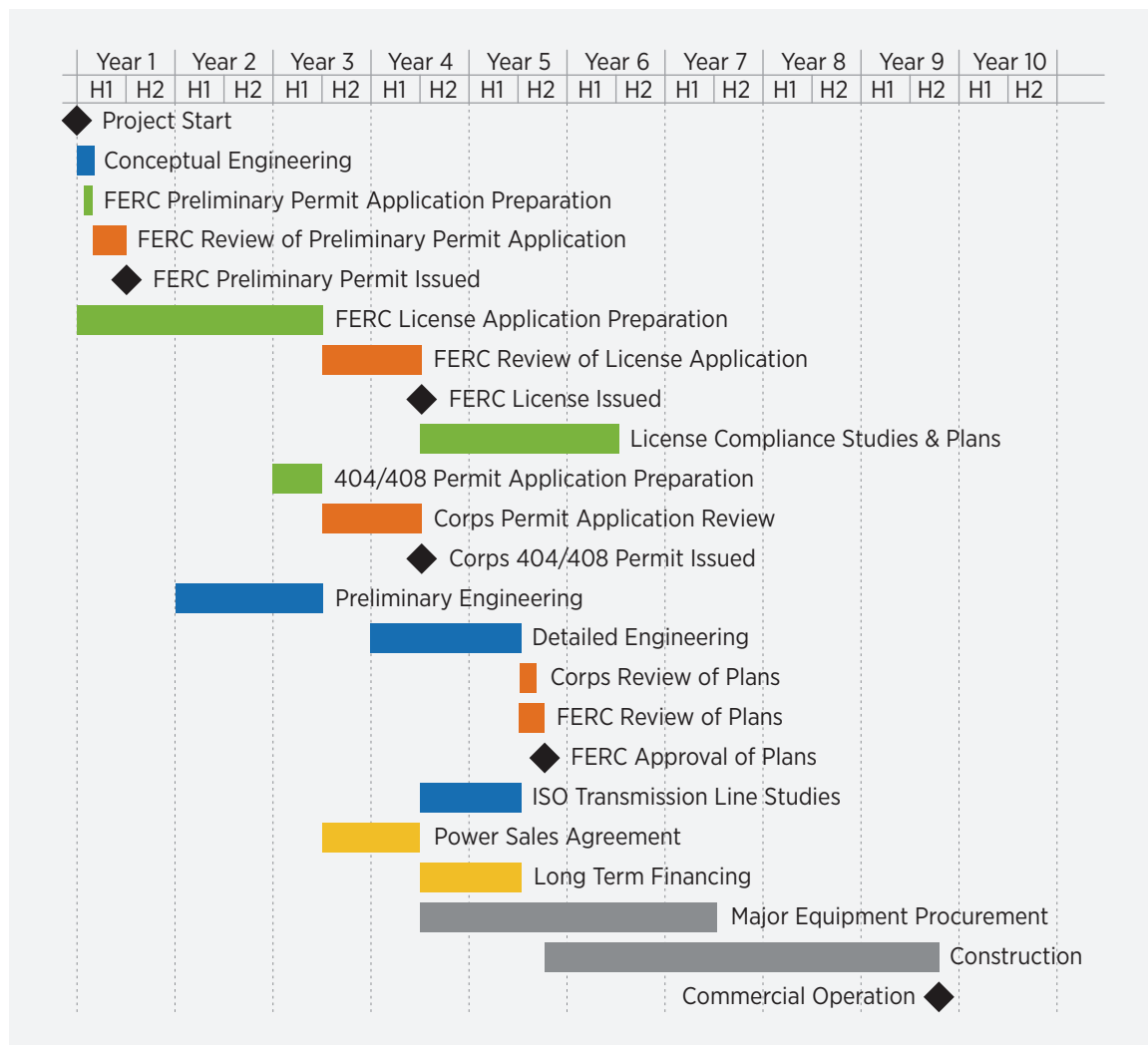

Source: Meier et al. 2010 [197]

**Figure 2-33.** Example of an accelerated development schedule for a hydropower project licensed under the Federal Energy Regulatory Commission

the timeline spans a decade. That timeline can lead developers and utilities to favor other generation technologies with shorter times to achieve commercial operation, such as natural gas turbines.

### **Reducing the Time and Cost of Licensing**

Hydropower growth is occurring through upgrades and additions at existing facilities, with hydropower generating equipment being added to non-powered dams and conduits, as well as to low-impact NSD [2]. One factor in the growth of hydropower is interest in all types of renewable energy resources, such that 37 states and the District of Columbia have legislation mandating RPSs for utilities (see Section 2.1.2). A second factor relates to the applicable legislation noted previously, namely the Hydropower Regulatory Efficiency Act of 2013 (see Table 2-2). The FERC regulatory framework has and continues to evolve; the Commission's internal reviews [198] identified permitting and regulatory processes as the most commonly cited challenges associated with hydropower

development in the United States. Permitting and regulation are important to ensure hydropower projects that meet multiple stakeholder priorities, but the process by which requirements are established can still be a source of uncertainty in the length and cost of project development timelines. This process can also be a source of uncertainty for the scope of facility operations, thus influencing the ongoing value available from hydropower generation.

FERC recognized the need for continual improvement in the licensing process in its 2001 publication, *Report on Hydroelectric Licensing Policies, Procedures, and Regulations Comprehensive Review and Recommendations Pursuant to Section 603 of the Energy Act Of 2000*. In this document, FERC examined the licensing of hydropower projects to determine how to reduce the cost and time of obtaining a license under the FPA. Key excerpts from the Executive Summary of this report, prepared before the aforementioned legislation in 2005 and 2013, are in Text Box 2-4 [198].<sup>63</sup>

Text Box 2-4.

### **Key excerpts from the Federal Energy Regulatory Commission's report:**

#### ***Report on Hydroelectric Licensing Policies, Procedures, and Regulations Comprehensive Review and Recommendations Pursuant to Section 603 of the Energy Act of 2000***

*"The median time from the filing a license application to its conclusion for recent applications is 43 months. Many proceedings, however, take substantially longer. Many specific factors contribute to delays, but the underlying source of most delays is a statutory scheme that disperses decision making among federal and state agencies acting independently of the Commission's proceedings. **The most common cause of long delayed proceedings is untimely receipt of state water quality certification under the Clean Water Act.**" (page 5)*

*"The same statutory scheme also ensures that the Commission has scant control over the costs of preparing a license application or of the costs of environmental mitigation and enhancement. These expenditures are frequently mandated in state water quality certification or mandatory federal agency conditions required pursuant to FPA Sections 4(e) and 18, and override the Commission's balancing of all relevant factors affecting the public interest." (page 6)*

*"The most effective way to reduce the cost and time of obtaining a hydropower license would be for Congress to make legislative changes necessary to restore the Commission's position as the sole federal decisional authority for licensing conditions and processes. Alternatively, consideration should be given to requiring other federal agencies with mandatory conditioning authority to better support their conditions." (page 6)*

*"Changes in Commission regulations and policies may also assist in reducing the time and cost of licensing, although they are not an adequate substitute for legislative reform." (page 6)*

63. Bolding in this section has been added by the *Hydropower Vision* authors. It is not included in the original FERC report.

Legislation issued since the issuance of this 2001 FERC report, and the introduction of the ILP as the default licensing process, has aimed to achieve greater efficiency and effectiveness. FERC and the hydropower community also continue to examine the regulatory framework. In 2005 and 2010, FERC explored the effectiveness of the ILP, as illustrated on the Commission's website<sup>64</sup>:

*"When the Commission adopted the Integrated Licensing Process (ILP) on July 23, 2003, it committed to studying the effectiveness of the ILP in achieving its goal of providing a more efficient and effective licensing process. In 2005 and again in 2010, Commission staff asked participants using the ILP about ideas, tools, and techniques that were being implemented (or could be implemented) to achieve the goals of the ILP within the framework of the existing regulations... The ILP Effectiveness Study confirmed that the ILP is achieving its purposes of providing an efficient and effective hydropower licensing process in most cases. The study also brought to light areas where each constituency (applicants, agencies, tribes, NGOs) could focus attention to improve the process. Commission staff is providing the following Action Plan for areas in its purview. We encourage other constituencies to do the same."*

Based on feedback from these initiatives, FERC developed its 2011 report, *Ideas for Implementing and Participating in the Integrated Licensing Process (ILP), Tools for Industry, Agencies, Tribes, Non-Governmental Organizations, Citizens, and FERC Staff, Version 2.0*. In this report, FERC describes its collaborative outreach to gather input and feedback [208]:

*"In 2005 and again in 2010, Federal Energy Regulatory Commission (FERC or Commission) staff explored with applicants, tribes, agencies, non-governmental agencies (NGO), and citizens how well the integrated licensing process (ILP) was achieving its goal of providing a predictable, efficient, and timely licensing process that ensured adequate resource protection. We asked what was going well and what might be done better. This document contains those shared ideas, tools, and techniques that have been successfully implemented (or could be implemented) to assist future ILP participants without unduly extending the licensing process or changing existing regulations" (page 3).*

Numerous suggestions were provided in the report for applicants, agencies, tribes, non-governmental organizations, and FERC staff. Many of those suggestions focused on improving communication, participation, and collaboration to facilitate the licensing process.

According to data provided by FERC in December 2015, there were 26 pending license applications where Commission staff has completed NEPA, but the Commission is unable to render a license decision because a state agency has not yet issued its water quality certification decision, or FWS or NMFS has not yet issued its biological opinion. As of December 2015, the average time the Commission has been awaiting water quality certification or biological opinions since completion of final NEPA is about 5.3 years.

To spur development of new sources of hydropower, it must be possible to establish economic viability with a degree of certainty early in the development process and increasing certainty as the process unfolds. Hydropower is a capital-intensive technology with long lead times for development and construction, due to the significant feasibility, planning, design, and civil engineering works required [30]. Project licensing and permitting are also costly and similarly lengthy. Payoff begins only after the project achieves commercial operation, often several years (5+) after initiation of the development process. Banks and other financial institutions require project development methodologies that appropriately manage risk, offer reasonable assurance for repayment of loans, and minimize the risk for capital cost growth [193].

The civil structures and electro-mechanical equipment are two major cost components for hydropower projects [30], but they can be more reliably estimated than some other components. Project development costs also include planning and feasibility assessments, environmental impact analysis, licensing, environmental mitigation measures, development of recreation amenities, historical and archaeological mitigation, and water quality monitoring and mitigation [30]. The initial and ongoing costs in those areas can be substantial as well as difficult to estimate at the early stages of project development.

Regulatory uncertainty in the duration and outcomes of the licensing process are important challenges for private hydropower developers. Another important challenge—perhaps the greatest challenge—for

64. <http://www.ferc.gov/industries/hydropower/gen-info/licensing/ilp/eff-eva.asp>



private developers is revenue uncertainty. Lenders will generally not finance projects without a long-term (typically 10+ years) PPA with a creditworthy counterparty, yielding a revenue stream with an acceptable debt-coverage ratio and a PPA term length that is equal to or greater than the term of the debt [193]. In addition to PPAs, interconnection cost is essential to project financial viability, because these two factors together determine the price of electricity that will be received, any other ancillary grid service revenues, future price escalation, and the cost of interconnection and wheeling (moving) project power to a power purchaser. Interconnection costs can vary widely depending upon the modifications required to carry the project power to the power purchaser [193]. The grid interconnection process can be a barrier to hydropower development (see Section 2.2), particularly for small hydropower. ISO interconnection application processes are typically costly and time-consuming, with their own timetables and priorities that are not necessarily consistent with the timeline needs of small hydropower developers [193].

### *Perspectives on Sustainability*

Many values factor into hydropower development, and there is growing recognition that those values need to sum to an amenable whole for the affected communities as well as the project owners over the life cycle of a facility. Regulatory and permitting processes address certain aspects of sustainability, and the inclusion of multiple stakeholder viewpoints during licensing encourages broad consideration of the related elements and objectives. However, there are opportunities for stakeholders to address sustainability questions even in advance of the regulatory process (e.g., third-party certification processes or design criteria that recognize “environmental performance” as a project goal). Low-impact certification programs and sustainability assessment protocols from organizations such as the LIHI and the International Hydropower Association provide examples of how hydropower operation and development can incorporate a broader perspective of performance. The LIHI certification program, for example, includes criteria related to river flows, water quality, fish passage and protection, watershed protection, threatened and endangered species protection, cultural resource protection, recreation, and facilities recommended for removal. The International Hydropower Association protocol addresses more than 20 sustainability topics in areas such as environmental, social, technical, economic, financial, and cross-cutting. Although the process for

incorporating sustainability into development is not always well defined, addressing a broader range of topics early in the process may make it possible to reduce uncertainty in the development timeline.

Stakeholders, including hydropower owners and developers, value a broad spectrum of multiple and even competing uses such as water supply, water quality, flood control, navigation, hydropower generation, fisheries, biodiversity, habitat preservation, fish passage, and recreation. Those values can extend beyond the boundaries of the project under development, and a basin-scale or watershed approach (even beyond that in the existing regulatory framework) can enable the evaluation of those values across multiple projects and in the context of other water uses. A basin-scale or watershed approach to hydropower development provides more options than a single plant approach, giving such approaches the potential to balance the competing needs of environmental resources, the project developer, and other interested stakeholders. For environmental resources, the benefits potentially include:

- Ability to coordinate for maximum effectiveness on efforts to protecting/restoring fish passage, improvements to fish habitat, and other ecological benefits; and
- Ability to institute watershed-wide protection and improvements sooner because they would not be contingent on licensing terms.

For the project developer and other interested stakeholders, the potential benefits can include:

- Greater collaboration among regulators, applicants, agencies, stakeholders, which has the potential to increase upfront certainty;
- The opportunity to create common settlement agreements, 401 water quality certifications, and other tools such as Habitat Conservation Plans and recreation plans for all projects in a basin at one time;
- A more comprehensive range of potential solutions in the basin, and opportunities that might not be apparent at smaller scales;
- Incorporation of integrated planning for climate change;
- Single process for consultations and environmental review (e.g., consolidated/coordinated NEPA); and
- Cost-effective collaborative studies, and more efficient mitigation and resultant reduction of overall project costs.

Text Box 2-5.

### Addressing Habitat Connectivity and Fish Passage Issues on the Penobscot River

Through an innovative FERC relicensing process, a multiparty agreement was signed in 2004 between the Penobscot Indian Nation, a hydropower company, conservation groups, and state and federal agencies. The agreement resolved decades of conflict over fisheries and hydropower. By considering a system of dams, the agreement supported increased power generation at six dams while increasing fish passage at five others. The agreement provided for the acquisition and decommissioning of three large main stem dams by the

Penobscot River Restoration Trust, with the removal of the two lower-most dams in 2012 and 2013 and a planned river-like bypass around an upstream dam [200]. These improvements were designed to increase access to an estimated 1,000 miles of habitat, and overall energy generation is already greater than pre-project levels. This project illustrates the creative problem solving and shared decision making that permitted this approach to balancing energy production with ecological values in the lower Penobscot River [199].

In many cases, factors such as staggered license expirations, conflicting objectives, multiple owners, increased complexity, requirements for mitigation within project bounds, and cost sharing can make it challenging to initiate a basin-scale or watershed approach. Basin-wide settlements<sup>65</sup> have existed for a number of years, including at least a dozen river basin settlements developed in New York since 1990 (such as the 1998 Raquette River Projects settlement). There are a growing number of success stories that have demonstrated the benefits of such an approach. One instructive example is the Penobscot River in Maine, where stakeholders successfully applied a basin-scale framework to address long-standing fish blockage and passage issues on the Penobscot River (Text Box 2-5) [199, 60].

The Penobscot process was the impetus for DOE to investigate a process and tools to look for similar opportunities elsewhere. The Basin-Scale Opportunity Assessment was one of the activities called for in the 2010 Hydropower Memorandum of Understanding between DOE, the U.S. Department of the Interior, and the Army [207]. The goal of the BSOA was to identify pathways to improve both the value of hydropower generation and environmental conditions within a river basin simultaneously. A three-phased approach to assessing hydropower environmental opportunities

was devised and piloted in the Deschutes River Basin, with subsequent work focusing on developing a geospatially driven methods and tools for conducting rapid scoping assessments (i.e., Phase 1). Basin-Scale Opportunity Assessment scoping assessment methodology was tested in three U.S. river basins (Connecticut, Roanoke, and Bighorn), and is being woven into an interactive Web platform that supports multi-scale association for any hydrologic drainage in the United States (e.g., Larson et al. 2014 [201]).

Basin-wide settlements<sup>66</sup> have existed for a number of years, including at least a dozen river basin settlements developed in New York since 1990 (such as the 1998 Raquette River Projects settlement).

### 2.4.3 Maintaining and Expanding the Existing Fleet

An important opportunity for additional hydropower development in the United States is through refurbishment and expansion of existing facilities. This can add incremental generation through efficiency increases and/or the addition of the ability to use water for generation that was previously spilled. The number of aging hydropower projects means that refurbishment will become an increasingly important way of boosting hydropower output and increasing capacity [30].

65. A negotiated agreement among stakeholders and the licensee(s) that requests FERC to include specific terms and conditions in the new license(s) for the project(s).

66. A negotiated agreement among stakeholders and the hydropower facility owner to FERC about relicensing, with a request to accept the terms as relicensing.

### Overview of the Resource

Hydropower plant refurbishment, which includes repowering and refurbishment, refers to a range of activities such as repair or replacement of components, upgrading generating capability, and altering water management capabilities. Most refurbishment projects focus on the electro-mechanical equipment, but can involve repairs or redesigns of intakes, penstocks, and tailwaters [30].

Refurbishment projects generally fall into two categories:

- **Life extensions** entail replacement of equipment on an “in-kind” basis, with limited effort made to boost generating capacity potential. This replacement will, however, generally result in increased generation (relative to what was being produced) as worn out equipment is replaced. On average, these repairs will yield a 2.5% gain in capacity [30].
- **Upgrades and expansions** reflect incorporation of increased capacity and, potentially, increased efficiencies into a refurbishment program. Typically, once the potential upgrade or expansion opportunity is identified, the owner will develop a business case to support the opportunity, such that costs incurred to accommodate these changes are offset or justified by increased revenues. These upgrades can be modest or more extensive in nature and, depending on the extent of the wear and tear and additional civil structures to try and capture more energy, yield increases in capacity of between 10% and as much as 30% at a given plant [30]. This can also include expansions to generate with minimum stream flow releases, or adding a new or larger unit to an underutilized facility (e.g., a facility with an unused bay or excess water).

Many hydropower projects in the United States are aging, with some facilities approaching the century mark. The median age for federal hydropower projects is approaching 50 years [2]. In the Columbia River Basin, for example, the Corps, BPA, tribes, and other stakeholders are working to replace aging turbines, generators, and associated equipment with new and more power-efficient designs that also address fish passage concerns. BPA and the Corps plan to replace more than 90 Kaplan units on the Columbia and Snake Rivers with newer units that both produce more energy and meet or exceed fish passage or other environmental mandates resulting from the ESA or Clean Water Act. Environmental performance

is incorporated through computational and scale physical models during the design process. Once new turbines are installed, performance is evaluated at full scale using tools such as the fish sensor device illustrated in Figure 2-38 in Section 2.5.4 to measure hydraulic conditions and acoustic telemetry to estimate fish survival rates. The result of this intensive process is increased confidence in both the expected performance of new turbines and actual performance that produces both energy-related and environmental benefits. Aging equipment is not limited to any particular region or organization, and hydropower operators across the United States will continue to refurbish or replace turbines.

### Key Issues and Challenges

Whether proposed and performed as part of relicensing or during the term of an existing license, upgrades, expansions and other types of operational changes (by non-federal owners) need to meet applicable FERC regulations germane to the proposed action (e.g. non-capacity amendment proceeding, capacity amendment proceeding, relicensing proceeding). Project developers and facility owner/operators operate within that context and often seek to meet power and environmental goals concurrently. For example, replacing an aging turbine with a modern design and materials evaluated through modern tools and techniques may produce power more efficiently across a wider range of conditions, reduce O&M costs, and create turbine conditions more conducive to improved water quality or fish survival. At Wanapum Dam on the Columbia River in Washington, for example, the turbine replacement process has increased energy generation by an average of 3.3%, while reducing maintenance costs and allowing for safer fish passage alternatives [202]. The replacement of the powerhouse at the Bridgewater Hydroelectric station on the Catawba River in North Carolina incorporated multiple aeration options into the turbines to meet tailrace water quality requirements [197].

Sustainability and environmental concerns can also drive the need for upgrades and improvements in an effort to simultaneously improve power generation and environmental performance. In general, facility upgrades and improvements represent excellent opportunities to add energy benefits in a sustainable way, particularly when objectives for sustainability are incorporated into the project planning process at an initial phase. The primary issue or challenge, especially with respect to license amendments, is to strike the

appropriate and needed balance in addressing the applicable power and non-power resources without the amendment becoming onerous or costly. Those costs may be offset if the incremental gains in hydropower are developed in such a way as to be eligible for renewable energy incentives and green certifications.

### 2.4.4 Non-Powered Dams and Existing Infrastructure

A second opportunity for additional hydropower development in the United States involves adding power generation capabilities to existing infrastructure, either at NPDs or in water conveyances such as irrigation canals and conduits. Such structures are initially constructed to provide other benefits and uses, so adding power generating facilities to them can often be achieved at lower cost, with less risk, and in a shorter timeframe than development requiring new dam construction. Similarly, canal and conduit hydropower takes advantage of existing infrastructure and can increase the energy efficiency of water delivery systems by replacing valves with generation. Although these water conveyance infrastructures were originally designed for non-power purposes, new renewable energy can often be obtained without affecting other purposes and without the need to construct new dams or diversions [193].

#### Overview of the Resource

The United States has more than 80,000 NPDs that provide a variety of services ranging from water supply to inland navigation (in contrast, there are only roughly 2,500, or 3%, of those dams that generate hydropower). The abundance, cost, and environmental favorability (due to utilizing an existing structure) of NPDs make these dams an attractive resource for hydropower development [21].

There are many thousands of miles of existing, man-made conduits in the United States that are used to transport and distribute water and wastewater. Conduit hydropower differs from more typical hydropower development in that it is not located on natural rivers or waterways, and therefore does not involve the environmental impacts that are associated with hydropower [193].

#### Key Issues and Challenges

Challenges to developing NPDs, canals, or conduits for hydropower generation include the need for additional comprehensive assessments associated with the existing infrastructure at canals and conduits;

concurrence on the type and level of study necessary; complex regulatory processes at the federal, state, and local levels; difficulties in securing project financing; potential operational conflicts between power generation and the existing purpose of the dam; unavailability and costs of transmission and associated facilities; and technological uncertainties associated with the longer-term performance of newer, more innovative, and potentially more cost-efficient technologies [193]. Additionally, development of hydropower on previously unlicensed water management structures may trigger a more rigorous standard for the structure itself than was acceptable prior to the addition of hydropower generation, even if the development changes little about how the structure or the water resource is managed. If a non-federal dam is being equipped with facilities that require a FERC license, for example, the applicant may have to bring the entire development up to current environmental (and dam safety) standards, versus simply addressing the additive effect of, for example, a small turbine.

The design of most existing NPDs, canals, and conduits includes no provisions for adding hydropower at a later time. As such, one of the major challenges in NPD development is avoiding major civil and structural modification. This challenge is exacerbated for smaller projects that may not justify a custom-engineered solution.

Modern principles of clean energy production can be incorporated into the development, and projects can adhere to strict environmental standards. For example, the Mahoning Creek Dam hydro project added 6 MW of generation capacity to a flood control dam and was certified as a “Low Impact” facility by the LIHI Certification Program. Certifications may, in some cases, provide additional benefits in improving the marketability and price of power.

Because they are closely tied to water use infrastructure, development of hydropower projects on canals or conduits may also provide innovative opportunities to further other water management goals such as irrigation, water conservation, enhanced instream flow, and dissolved gas management. Opportunities associated with irrigation systems are often identified in conjunction with comprehensive system analyses looking for efficiencies and conservation opportunities. There are examples of in-canal and conduit projects being carried out throughout the western United States in ways that generate additional benefits, as illustrated by the projects discussed in Text Box 2-6.

Text Box 2-6.

### Partnering for Successful Conduit Projects

The Juniper Ridge and Ponderosa hydropower projects are in-canal projects located north of Bend, Oregon. Both projects were completed in 2010 and FERC issued conduit exemptions from licensing. The Juniper Ridge Project was constructed by the Central Oregon Irrigation District in conjunction with a 2.5-mile-long canal lining project and has an installed capacity of 5 MW. The Ponderosa Project was constructed by Swalley Irrigation District in conjunction with a 5-mile-long irrigation canal lining project and has an installed capacity of 0.75 MW. Both projects generate power during the irrigation season when water is being conveyed in the canals.

The Juniper Ridge and Ponderosa projects both represent unique partnerships between irrigation districts, the environmental community, the state of Oregon (through state programs like the Allocation of Conserved Water Program and the now defunct Business Energy Tax Credit), and others. These partnerships meet multiple goals, including water conservation, stream restoration, enhanced flows, hydropower generation, energy savings, and more efficient operation for irrigation districts. Oregon's Conserved Water Program allows water rights holders who conserve water to lease or sell a portion of that water (75%, with 25% going back instream), creating a revenue stream to fund development projects like canal lining and piping [203].

The Deschutes River Conservancy worked closely with Swalley Irrigation District and Central Oregon Irrigation District through the Conserved Water Program to facilitate conserved water piping projects and put the saved water back into the main stem of the Deschutes River. Piping projects created head and an opportunity for small hydropower generation at the end of the pipe. Central Oregon Irrigation District and Swalley Irrigation District used



**Ponderosa Hydropower Project** Photo courtesy Gary Johnson, Pacific Northwest National Laboratory

funds from the sale of conserved water and assembled a financing package from loans, grants, and other means to fund piping and construction of hydropower facilities. Revenue from the sale of hydropower is now being used to pay back project debt over time.

When projects like this are successful, hydropower is one part of the equation, enabling improvements to irrigation infrastructure as well as conservation of water resources. There are challenges associated with these projects, however, including high utility wheeling costs, uncertainty around fish passage requirements, long payback periods, challenging local siting and permitting issues, and the need for strong coalitions and unique funding arrangements. In addition, funding from ARRA—a stand-alone (vs. recurring) investment—was important for both of these projects. Reducing costs of hydropower technologies, reducing costs of or the need to wheel power to the utility (using it onsite, for example, to offset pumping costs), and reducing siting and permitting costs will likely be needed for future successful project economics. Exploring new ways to fund projects through public/private partnerships and co-locating generation with load could present new opportunities.



## 2.4.5 New Stream-Reach Development

Developing new “greenfield” projects in water bodies with no existing dams or hydropower projects is known as new stream-reach development, or NSD. NSD can also consist of a new dam developed by a non-hydropower entity for drinking water supply or flood control; hydropower facilities can be co-located at such sites. Successful NSD requires consideration for environmental and social impacts that can result from this type of development.

In the United States, dams can provide numerous benefits, including hydropower. However, tens of thousands of non-hydropower dams across the country are obsolete and are no longer serving their intended purpose, and many are in a deficient condition and pose a threat to public safety. More than 1,000 obsolete dams in the United States have been removed in the last century, and with each successful removal the science supporting removal and recovery processes has grown. As a result, locally driven removals of non-hydropower, obsolete dams are occurring at an increasing rate and are reducing public safety risks while improving the health of our rivers. Building on these successes and advancing additional locally supported removals could help complement consideration of NSD potential, where together, the two efforts could increase energy yield while further addressing the widespread environmental and public safety problems of these obsolete dams.

### *Overview of the Resource*

Developers and researchers can use information about river morphology, hydrology, and the locations of existing dams to identify river reaches with untapped hydraulic head. Resource assessments have identified an array of sites with the technically recoverable potential for generating hydropower (Table 2-5; [65]). Assessments at the national scale account for factors that would preclude development, such as designation as a National Park, Wild and Scenic River, or Wilderness Area, but even sites that appear promising when evaluated at the national scale require comprehensive feasibility assessments at watershed or basin scales. More focused assessments direct developers toward the most promising sites, which can then be evaluated further for viability. Detailed assessment would need to consider, for example, the potential presence of threatened and endangered species, cultural sites, and other sensitive or protected resources.

### *Key Issues and Challenges*

To be successful, NSD must incorporate the lessons learned from earlier hydropower development in the United States and elsewhere. These lessons reflect primarily on the need to avoid or minimize environmental and societal impacts. Therefore, the benefits of new hydropower must be evaluated within the context of related impacts to the community, the environment, and other values with the participation of the stakeholders. It is also important to recognize that historical and new dam or conduit construction has not always been driven by hydropower development. As in the past, the purpose or need for new dams may be driven by non-power uses (e.g., water supply, flood control, navigation). The addition of hydropower can be considered in the context of the dam that is being constructed and operated to achieve other purposes. The existence of multiple use benefits could be revealed by conducting more detailed assessments.

NSD efforts are subjected to more scrutiny than refurbishments or NPDs because such development may require construction of a dam or diversion at a previously undeveloped location. NSD site characteristics must be documented and site suitability evaluated as required by the applicable regulatory framework and augmented by basin-scale approaches. Studies to address environmental concerns may have limited baseline information from which to draw, so developers may be forced to collect this information. Developers cannot assume that they can gain easy access to the transmission grid, so additional agreements with land owners and host utilities may be required. Coordination with other hydropower operations and water management activities in the basin may be needed to accurately estimate the timing and quantity of available flows.

The unique nature of NSD can add cost, time, and uncertainty to the development process. Developer costs must be offset by potential payback, which is usually driven by the amount and value of energy that will be generated. These factors have the effect of decreasing the feasibility of NSD in general, and particularly for smaller projects where the payback might not be sufficient to justify the costs. The ability to incorporate multiple uses and benefits could increase the potential payback and could increase the feasibility of development. Efforts to reduce uncertainty would reduce financial risks and help to identify the most feasible sites.

**Table 2-5.** Summary of New Stream-Reach Development Findings by Hydrologic Region

Hydrologic Region	Capacity (MW)	Generation (MWh/year)	Capacity factor
1. New England	2,025	11,791,000	66%
2. Mid-Atlantic	4,144	22,721,000	63%
3. South Atlantic-Gulf	2,439	13,494,000	63%
4. Great Lakes	1,338	7,870,000	67%
5. Ohio	3,795	19,986,000	60%
6. Tennessee	1,228	7,229,000	67%
7. Upper Mississippi	1,983	10,937,000	63%
8. Lower Mississippi	2,067	12,044,000	67%
9. Souris-Red-Rainy	142	737,000	59%
10. Missouri	10,705	63,090,000	67%
11. Arkansas-White-Red	5,771	32,687,000	65%
12. Texas-Gulf	762	3,565,000	53%
13. Rio Grande	1,103	6,237,000	65%
14. Upper Colorado	1,914	11,481,000	68%
15. Lower Colorado	622	3,761,000	69%
16. Great Basin	547	3,008,000	63%
17. Pacific Northwest	16,958	97,859,000	66%
18. California	3,275	18,084,000	63%
19. Alaska*	4,530	(not estimated)	(not estimated)
20. Hawaii*	145	699,000	55%
<b>Total</b>	65,493	347,280,000	61%

Note: Excludes stream-reaches in close proximity to national parks, designated wild and scenic rivers, and wilderness areas

Source: Kao et al 2014 [65]

## 2.4.6 Bridging the Gaps in Hydropower Development

Hydropower development can contribute to advancing a low-carbon future energy system. Building upon Section 2.1 and the preceding portions of Section 2.4, this section discusses three primary concepts for bridging the gaps between the existing hydropower development process and the concepts discussed as part of the *Hydropower Vision Roadmap* (Chapter 4 of the *Hydropower Vision* report):

- Improved collaboration among developers, regulators, and stakeholders early in the development process;
- Planning at the basin or watershed scale to identify opportunities and address issues that may not be evident at individual projects;
- The importance of sustainability, interconnection, and revenue to the viability of a project;
- Consideration of the influence of climate change on water availability, variability, and competing uses; and
- The ability of the project to support grid integration of variable renewables.

Addressing these themes can help reduce costs and uncertainty associated with hydropower development requirements, and thus enhances the potential to accelerate development of additional sources of hydropower.

As an example of collaboration early in the development process, American Rivers has proposed a “Collaborative Development Process” that highlights and encourages the best practices of typical or existing development processes, and which addresses some of the common themes identified in this section [195]. These practices are based on American Rivers’ experience in and assessment of hydropower licensing. The proposed development process is based on the idea that the societal value of rivers and watersheds, and the potentially competing uses of these resources, is often overlooked early in the development process. Examples of these societal values and competing uses include navigation, trade, manufacturing and transportation, riverine habitat, recreation, boating, tourism, waste disposal, flood protection, water storage, energy production, cooling and urban development needs [195].

One of the goals of the proposed development paradigm is to reduce uncertainty about a hydropower facility project early in the conceptual design stage, before significant amounts of time and capital have been invested in a design. Additional goals of this new paradigm include resolving as much conflict as possible, creating a focus on broader economic and community benefits versus purely financial returns of the project, identifying and promoting ancillary and grid reliability benefits, and generally easing the permitting process or identifying pitfalls early in the process [195].

American Rivers’ proposed Collaborative Development Process includes water users and stakeholders as early as the prefeasibility phase. In doing so, the process facilitates the identification of more than one technical option for the system design, a description of operational alternatives, and more refinement of the elements in the feasibility assessment to incorporate the needs of relevant user groups. According to American Rivers, the permitting phase would no longer be a discovery process for regulators and community groups, but rather a confirmation of the work and efforts in previous stages [195]. Tackling uncertainties in a collaborative manner, early in the development process, holds the promise of reducing unexpected delay or expense during the permitting phase.

As discussed previously, basin-scale or watershed planning enables project developers and other stakeholders to evaluate various social, economic, and environmental values across multiple projects and in the context of other water uses. Such an approach facilitates the evaluation of a more comprehensive range of options and is more likely to identify the best means to achieve multiple goals over the entire basin or watershed. Although hydropower’s environmental performance has been and can continue to be improved through project design and operation (e.g., environmental flow releases, fish protection and passage, water quality), other important potential impacts and benefits from hydropower development (particularly new dams) cannot be fully evaluated for mitigation strategies if examined only at the level of an individual dam. Without proper planning and siting at the river basin or “system” scale, opportunities for more optimal and balanced outcomes can be missed, such as meeting energy needs while maintaining and protecting other key environmental and social values in a river basin [204].

The Nature Conservancy has developed a simple framework that can build and compare development scenarios in an iterative fashion, seeking balanced outcomes across multiple values [204]. The framework focuses on the scale of a large river basin and is illustrated with analysis of a hypothetical river basin—though hypothetical, the data were adapted from real-world geographical information for three value sets: economic (hydropower capacity and cost of energy); indigenous/social values as represented by indigenous reserves; and environmental/ecological values, represented by a biodiversity “portfolio” and connectivity of the river system. The analysis compared twelve development scenarios [204].

The key result from Nature Conservancy analysis was that, for a given energy output, there was a fairly wide range in the output of other values. This example supports the hypothesis that, through river basin-scale planning, energy targets can be achieved with a more balanced output of other river values than can be achieved through individual project selection, with no significant difference in cost [204]. The Nature Conservancy’s 2015 publication, “The Power of Rivers,” discusses hydropower expansion scenarios that balance for community and environmental needs. The analysis discussed in the report models impacts to river flow patterns and connectivity networks to estimate potential impacts from hydropower expansion [205].

Interconnection and revenue are also important aspects in considering hydropower development. Various industry groups such as the Interstate Renewable Energy Council have been working with state public utility commissions to improve interconnection procedures by identifying and promulgating procedural best practices [206]. One such practice is to make available a pre-application report, which can enable project developers to better choose appropriate locations [193]. Related federal efforts to improve interconnection include FERC Order 792, issued in November 2013, which establishes new rules for small generator interconnection agreements and procedures. At the state level, California’s Rule 21 describes the interconnection, operating, and metering requirements for generation facilities to be connected to a utility’s distribution system [193]. If interconnection requirements are simplified and costs can be reduced, these factors can become less of a barrier to hydropower development.

## 2.4.7 Trends and Opportunities

Trends and opportunities for Hydropower Development include:

- Enhancement of stakeholder engagement and understanding within the regulatory domain and improvement in the predictability in scope and timeline, and collaboration among stakeholders, to aid licensing and permitting processes. These activities and others should help provide insights into achieving improved regulatory outcomes.
- Evaluation of the environmental sustainability of new hydropower facilities to increase appreciation of the importance of sustainability to the viability of a new project. Likewise, acceleration of stakeholder access to new science and innovation and analysis of policy impact scenarios should contribute to achieving regulatory objectives.
- Simplification and standardization of the grid interconnection process to aid development of small hydropower.
- Implementation of a basin-scale or watershed approach to hydropower development to offer more opportunities than a single plant approach and provide additional options for potential benefits to all stakeholders.
- Improvement in integration of water use within basins and watersheds. This might be achieved by identifying pathways to improve both hydropower values and environmental conditions within a river basin simultaneously, such as through basin-scale planning, especially in the context of resiliency to climate change.
- Increasing resilience of water management systems, hydropower generation, and ecological systems to climate alteration.

These trends and opportunities can help accelerate the development of new low-carbon hydropower generation.

## 2.5 Design, Infrastructure, and Technology

Hydropower facilities have a number of unique features, including certain structures, operating systems, and generating equipment. Though existing hydropower technologies are mature, advanced, and efficient, there are opportunities to increase hydropower potential through technology innovation and

### Highlights:

- Advances in research and design of hydropower facilities are ongoing, covering civil structures, turbines, electrical components, governors, and instrumentation, control, and monitoring equipment.
- Technology advances will reduce the cost and construction time of civil structures. Important advances include modular and segmental design, precast systems, smart concrete technology, and rock-bolted underpinning systems.
- Advancements in powertrain technologies, equipment manufacturing, and project design will also help reduce costs, thereby improving economic viability.
- Environmental protection technologies, such as fish screens, aerating turbines, and surface flow outlets, have been developed to avoid or minimize the impact of hydropower operations.

cost reduction. This section discusses opportunities for improvements in hydropower plant design and construction, technologies to increase generation efficiency, cost reductions, and designs that meet environmental obligations. Special attention is given to advanced and innovative technologies that facilitate hydropower development; e.g., the technology advances described in this section are relevant to hydropower refurbishments described in Section 2.4, Hydropower Development.

### 2.5.1 Uniqueness and Types of Hydropower Projects

Every hydropower facility is sited and designed in response to unique location-specific factors. Factors related to siting a hydropower facility include but are not limited to the local geography, topography and geology, characteristics of upper and lower reservoirs, elevation, distance between reservoirs, flow between reservoirs, environmental and competing use constraints, and transmission connections. Because any given site is characterized by a distinct combination of these factors, each facility is usually customized. Designs take into account civil issues related to site access; reservoir creation; water conveyance from one reservoir to another; powerhouse construction, including excavation issues; equipment design parameters such as number of units, unit size, unit speed, unit setting, and substation design; and issues related to environmental effects. The power train components that go into the design of a hydropower generating unit are shown in Figure 2-34. The optimum solution is often measured in economic terms, and a custom-engineered design must balance these factors against cost, construction time, and environmental considerations.

#### *Types of Hydropower Facilities*

A wide variety of hydropower facilities exist, including small and large projects; facilities with dams, spillways, and impoundment reservoirs; facilities with a diversion system and no dams; facilities in conduits (canals and pipelines); facilities that are run-of-river with no active water storage; facilities with a variety of reservoir storage uses; and PSH (discussed in Section 2.5.1.2). A hydropower project can have a reservoir created by a dam, barrage, or diversion point that channels water into a tunnel, pipeline (penstock), or canal. Regulating gates and equipment are typically located at the point of diversion where water is transported to a powerhouse. In some cases, the powerhouse is a part of the dam, connected with a short water conduit or pipeline. The elevation difference from the water level at the point of the diversion to the water level on the downstream side of the powerhouse is often referred to as the gross head, and energy lost in moving water to the power plant from the upper reservoir is usually referred to



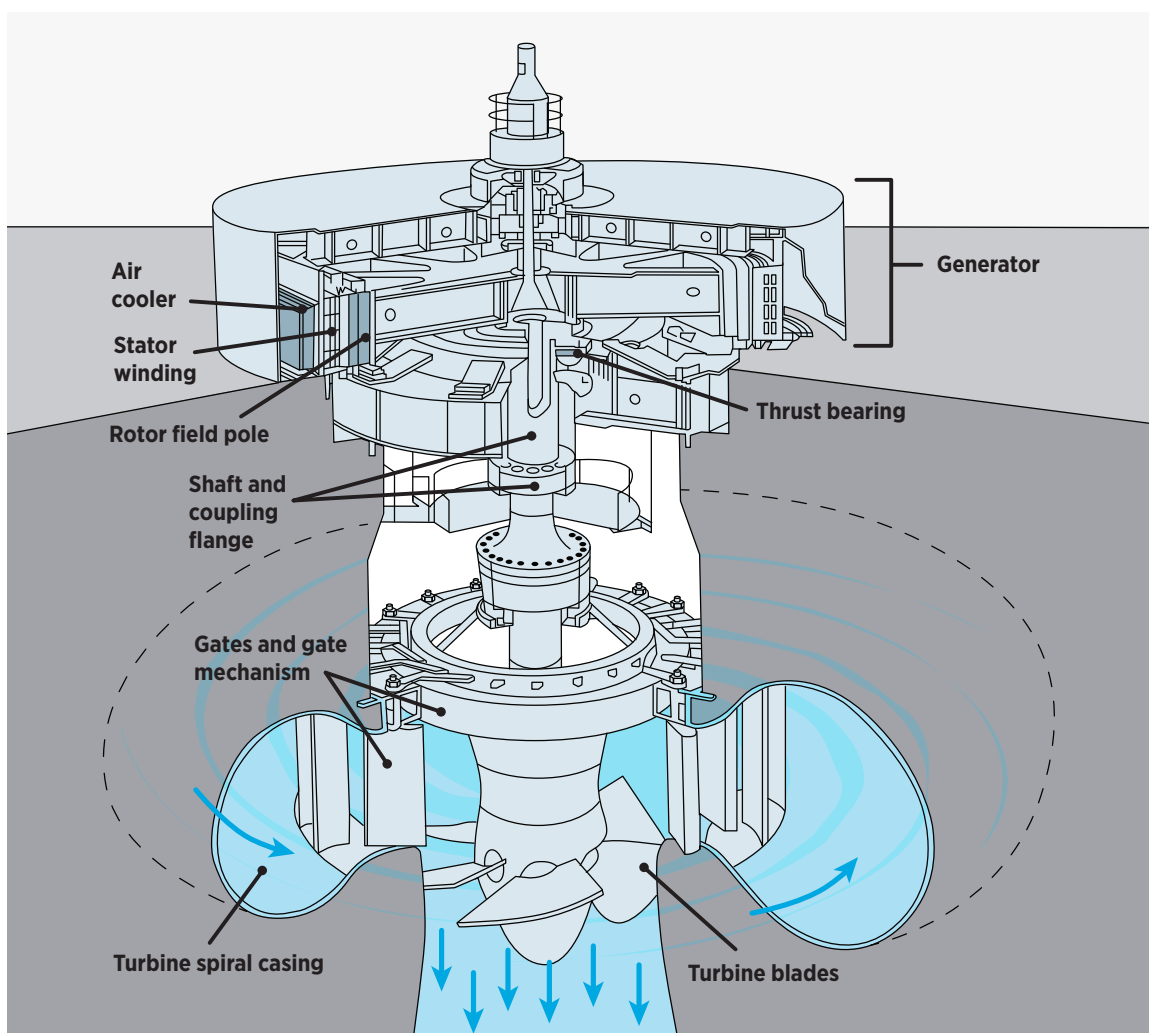

Source: Artinaid [209]

**Figure 2-34.** Example of the power train components of a representative hydropower plant

as head loss. It is the combination of the available net head (gross head minus the head loss) and water flow rate that provide the hydraulic power of water.

**Impoundment Systems.** An impoundment system contains and stores water. Impoundment systems can be entirely natural, such as a lake or river, or water in a cave or cavern. Man-made impoundment systems like large tanks or underground mines are also common. The most familiar man-made impoundment is the water behind a dam, normally constructed of earth, rock-fill, or concrete. Manmade impoundments have a spillway, which allows water to be transferred safely downstream when an excessive amount of

water is flowing into the impoundment. This ensures that public safety is not jeopardized, nor is the safety and integrity of the structures forming the impoundment. Reservoir impoundments can be shallow (<10 feet) or deep (>100 feet). Depending on the size of the impoundment, the volume of water can range from one thousand gallons to billions of gallons.

**Diversion Systems.** The act of channeling water into a tunnel, pipeline, or canal is referred to as diversion. In these types of projects, water is diverted from the reservoir, lake, or river through a water conduit to the hydraulic turbines in the powerhouse for hydropower generation. Water can also be diverted for other

purposes, such as environmental flows, irrigation, or municipal use. Diversion systems may include pump stations at the point of diversion to facilitate water distribution for the various uses. Water can also be diverted into a spillway or other man-made structure.

Diversion systems can include intake gates with hoists, trash racks, stop logs, or flow measurement devices. A newer type of diversion is the coanda screen, a stationary intake screen placed over a channel within a water overflow concrete structure that diverts water into a pipeline or canal. The screen is largely self-cleaning, using the natural flow of water, and the screen mesh is tight enough that it prevents trash, larger sediment, and fish from entering into the channel. Another type of diversion is created by a rubber dam or Obermeyer crest gate. During flood events, these structures can be lowered to allow flood flows to pass, and then raised again for storage and for directing the flow into diversion structure once the flood flows pass over.

**Conduit (Canal and Pipeline).** There are thousands of miles of canal and pipeline within the United States that convey water. Conduit hydropower could use existing infrastructure to manage the potential hydraulic energy. For canal installations, there is an intake structure, a conduit, and a powerhouse and substation. There are typically no reservoir impoundments in canal or pipeline systems, though there may be one upstream of the canal or pipeline. Such an impediment would be used for water delivery, and not for producing hydropower. All conduit hydropower development must incorporate a mechanism to bypass water and prevent any interruption in the water delivery system.

Conduit hydropower projects use the head between two water levels within a canal, or the available pressure within a pipeline system. These installations typically have relatively constant net head, flow, and water velocity. There are cases in which flow and water velocity can vary, but they are generally still predictable within an annual cycle. This makes the determination of installed capacity and energy estimates for a prospective hydropower installation more reliable, and reduces the climatological and flow variability risk associated with a typical run-of-river installation. These benefits are attractive from a development and investment standpoint, because, typically, the uncertainty regarding hydrologic prediction and climate change is a prime concern to investors.

**Run-of-River Projects.** Run-of-river hydropower projects are characteristically situated within a stream or river system, and pass water at roughly the same rate as it enters the reservoirs behind the dams to generate electricity. Typically, they are configured to minimize interruption of the natural stream and river flow conditions, often using water-level sensors to keep specific levels constant. A diversion structure guides river water into an intake, where it is transported through a penstock to a powerhouse and substation. An overflow structure allows large river flood flows to pass safely.

Run-of-river projects experience a range of flows that vary throughout an annual and year-to-year hydrologic cycle. Typically, the run-of-river flow rate is predicted using streamflow gauge measurements from prior years, but there is no guarantee that the flows experienced in one year will be consistent with the flows experienced in another year. In some cases, an existing reservoir upstream of a proposed run-of-river project can actually make flow estimates more predictable. The net head is also predictable for many run-of-river projects.

**Storage Projects.** The term “water storage” typically refers to the collection and storing of naturally flowing water and passing it at a later time. In hydro-power facilities with storage capabilities, water is stored for a limited time and then released to meet energy demand. This type of storage is broadly classified as either peaking or pulsing. Storage projects are mostly used for peaking generation to meet water or energy demand at a given time by delivering stored water to the generating equipment during a shorter, concentrated period. Most peaking facilities will only generate electricity during certain hours of the day, when energy demand is highest. Water and energy peaking can vary widely to suit a variety of industrial, commercial, and residential requirements. Additionally, these projects are often used for pulsing to increase or decrease stream and reservoir flows within a set time period (day, week, month, or year). Typically, pulsing is a human-regulated operation in which reservoir storage is released to create a desired set of flow conditions downstream, but it can also be scheduled to coincide with naturally occurring flows, like a snowpack melt during the freshet (spring thaw) period. Pulsing can be used to enhance environmental conditions, meet social requirements such as recreational flows, and create favorable generation conditions in downstream hydropower

facilities. Operating storage projects require an operating guide or “rule” curve which is function of the multi-purpose demands and requirements of the project, mainly flood control, recreation, irrigation, water supply, and others.

### ***Pumped Storage Hydropower***

PSH is a unique type of hydropower that offers the ability to store and return large quantities of energy. The typical mode of operation for PSH is to pump water to an upper reservoir during off-peak times and use it generate later to meet peak grid requirements. PSH is the only grid-scale energy storage technology that has been used extensively for more than 100 years. PSH uses an upper reservoir to store energy in the form of water that has been pumped from a second reservoir at a lower elevation; this can be in either a closed or open loop. This stored energy is then released during periods of high electricity demand, in the same manner as a traditional hydropower station. The upper reservoir is recharged during periods of low energy prices by pumping water back into the reservoir when energy supplies are more abundant and the cost of energy is often much lower. This energy storage ability allows for a more optimal dispatch of all generating resources to meet the constantly changing electrical demands of consumers. Typically, PSH roundtrip efficiency is about 80%. PSH is discussed in detail in Section 2.7.

## **2.5.2 Primary Features of Hydropower Facilities**

Hydropower facilities generally comprise civil structures; turbines; electrical components; governors; and instrumentation, control, and monitoring equipment. Advances in research and design in all areas are being pursued by the hydropower industry, as described below.

### ***Civil Structures***

Hydropower dams impound water by forming an impervious barrier across a channel. The civil structures associated with hydropower developments are commonly the most extensive and costly components of a project, often 50% of total project costs. They are, however, essential to hydropower generation. “Civil structures” (sometimes also called “civil works”) is loosely defined to include dams, spillways, powerhouses, water conveyance systems, and, where appropriate, facilities to protect or allow the passage of fish.

**Dams.** There are thousands of dams in the United States serving multiple purposes, including flood control, irrigation, water supply, navigation, and hydropower. These dams come in many shapes and sizes, and have proven to be reliable and safe. The rare cases of dam failure have most often been due to foundation failure or to a structure that was not engineered correctly.

Modern dams may be classified as gravity, embankment, arch, or a combination of these. Gravity dams are generally concrete or masonry structures that impound water using only the weight of the dam structure. Embankment dams comprise earthen or rock-fill embankments watertight by a central impervious core of clay or similar material, or an impervious upstream face of reinforced concrete, asphalt, or a synthetic polymer. Buttress dams use a series of concrete counterforts that support an impervious face. The buttresses transmit the water load to the foundation. Arch dams impound water, the forces of the impounded water compresses the arch dam, thus, transferring force to the dam abutments. The most well-known arch dam in the United States is probably the Hoover Dam. Structural configurations for dams include concrete arch, concrete gravity, roller compacted-concrete arch, and roller compacted-concrete gravity. Concrete-face rock-fill dams are a combination of rock and reinforced concrete.

**Spillways.** Dams include a structure to allow the discharge of river flows that cannot be passed through the turbines or other water works. These structures are generally referred to as spillways. Once the available storage capacity of the reservoir has been used, the spillway discharges flows that exceed the capability of the turbines. Spillways are sometimes used to discharge flows for environmental reasons ranging from fish passage to aeration of the water. Spills (flows) from the spillways of large, high dams may result in high levels of total dissolved gas (TDG), which is a significant environmental concern with regard to fish.

Since spillways must contain the flow of water without damage, they are generally concrete and may be incorporated into the dam structure. The simplest spillway has no gates or other regulating systems, and consists of a curved concrete shape in cross-section that passes flows when the elevation of impounded water exceeds the crest of the spillway. More complex spillways are equipped with various types of flow control systems, such as Tainter gates, slide gates, sluice gates, and drum gates, among others.

Spillways generally discharge water past the dam into the downstream river channel. Variations include spillways discharging into an underground water passage, or spillways built into side channels in the surrounding topography. Some spillways are gated and some are ungated.

**Water Conveyance Structures.** Water conveyance structures for hydropower plants, generally controlled by gates, carry flows from the reservoir or impoundment to the turbines. These water conveyance structures are typically a penstock connecting an intake structure in the reservoir to the turbines, or a canal extending from the impoundment to the plant's intake structure, or a turbine intake at low head project. A water conveyance system that discharges minimum flows for fish or habitat protection may also be built into the dam or reservoir.

**Powerhouses.** The powerhouse is the structure that contains the turbines, generators, and associated controls. Depending on the size of the system and number of turbines, the powerhouse may also have an assembly bay where equipment can be overhauled. For small hydropower plants, the powerhouse

may operate remotely and contain only the turbines and generating equipment, with maintenance and inspection conducted by centrally dispatched teams as needed. Though less common, large multi-unit projects may also be operated remotely.

Powerhouses may be completely enclosed facilities, outdoor, or semi-outdoor facilities in which weather-proof equipment is outdoors or under hatches, or located entirely underground. The selection of design depends on the location, topography, and type of project.

**Fish Protection and Passage Facilities.** Fish protection and passage are important features at some hydropower projects, especially those where migratory species are present. To protect aquatic resources, projects may employ a variety of techniques, such as fish ladders that provide an upstream migratory path for fish to pass a dam, fish screens, and associated bypass systems and outfalls to reduce fish entrainment into turbines; and fish collection techniques to facilitate the physical transportation of fish around hydropower facilities.

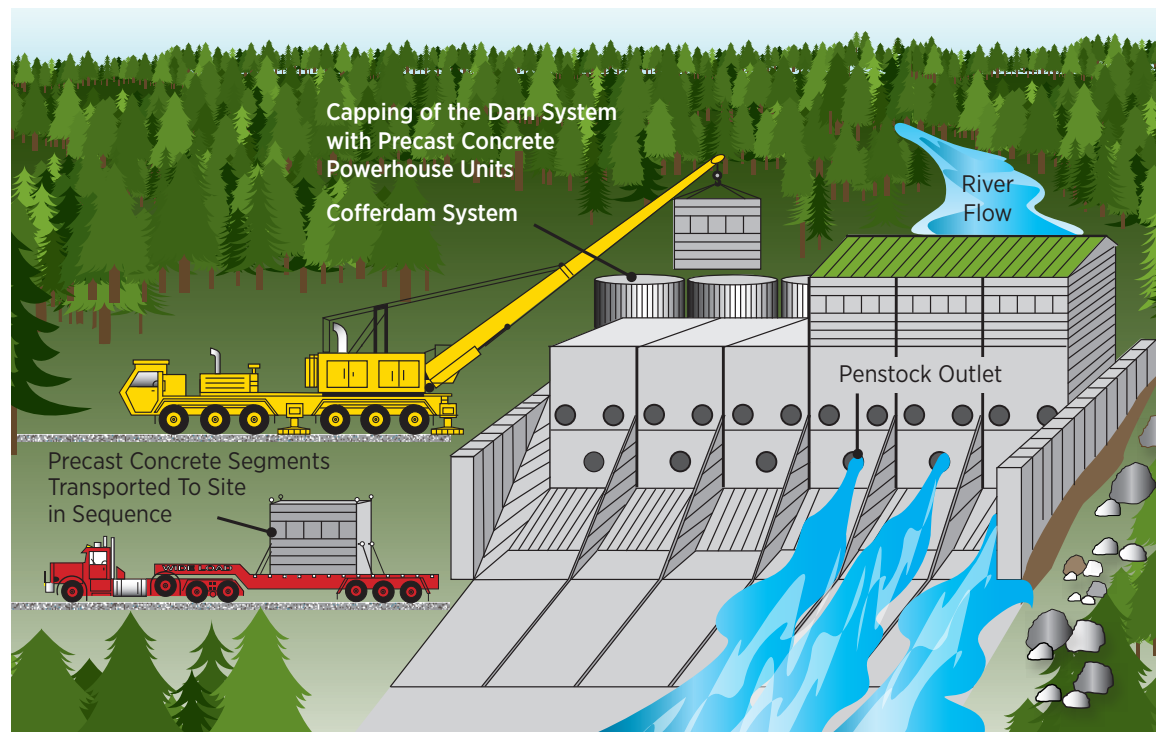

Source: French Development Enterprises [210]

**Figure 2-35.** Conceptual depiction of a small hydropower construction operation involving an intelligent precast system

### Advancements in Research and Design of Civil Structures.

The following advancements in research and design of dams are being implemented to help reduce the cost of civil structures and minimize construction time:

- **Modular and Segmental Design:** Modular and segmental technology facilitates the development of a standardized family of structures designed to accept multiple equipment types, which facilitates flexible service and upgrade options. Onsite installation can be done in a fraction of the time needed for traditional methods and using standard construction equipment. Modular and segmental technology can be used for construction of the entire dam, including upper and lower stream spillways.
- **Precast Systems:** A precast modular system is a combination of factory-manufactured concrete segments that are connected together to become a larger structure (Figure 2-35). Precast concrete segments are prepared, cast, and cured at a specially equipped off-site location (i.e., not co-located with the hydropower facility). Once precast concrete segments pass quality controls, they are stored to await delivery and are transported as needed for onsite installation.
- **Glass Fiber Reinforced Concrete:** Glass fiber-reinforced concrete is a cement-based composite, with alkali-resistant fibers randomly dispersed throughout the product. The fibers serve a purpose similar to the steel in reinforced concrete, which is placed primarily in tensile stress areas. Using this advanced precast concrete method may result in an increased product lifespan of the structure.
- **Smart Concrete Technology:** Adding conductive carbon fibers to a precast concrete structure enables the material to provide real-time load information on the structure, thus allowing structural engineers to identify trouble spots long before stress or cracking is visible to the human eye.
- **Rock-Bolted Underpinning System:** A GPS-guided, rock-bolted underpinning system provides linkage to the riverbed, allowing for ease of installation and fastening of the structure into place. Each segment is secured to the riverbed or an existing retrofit dam by multiple rock bolts, each of which is capable of sustaining large loads.

### Turbines

In a hydropower facility, turbines harness the kinetic energy in flowing water. To do so, water is channeled into and through the turbine, which drives an electrical generator or other mechanical device (pump, grinding machine, saw, or grist mill). The power captured depends on the head and the flow rate (volume per unit time) of water through the turbine. Water passing through the turbines forces the rotational movement of turbine blades, which are attached to a shaft. This movement causes the shaft to rotate. The shaft is typically connected to a generator, which transforms kinetic energy into electricity. (Text Box 2-7)

Turbines usually consist of four parts:

- The inlet portion, or penstock, bringing water into the turbine;
- The turbine casing with flow regulation, which surrounds the runner;
- The runner being the moving part inside the turbine, which rotates a shaft; and
- The water conveyance or draft tube that returns water to the river below the dam.,

Text Box 2-7.

#### Cavitation: Bubbles vs. Steel

Cavitation is a phenomenon that affects reaction turbines when, under certain operation conditions, vapor bubbles form and collapse due to rapid pressure changes in the water moving through a turbine. When the vapor bubbles collapse, they generate shock waves that create pits on the metal surface. Damages caused by cavitation include erosion of material from turbine parts, distortion of blade angle, and loss of efficiency due to erosion/distortion. Cavitation damage is usually the most costly maintenance item on a hydroelectric turbine because of the unexpected shut-downs and unplanned maintenance required for repairs. Design measures can be implemented to prevent cavitation damage, such as minimizing pressure variations, increasing material hardness, and using cavitation-resistant surface coatings.



All turbine components are selected based on the parameters of the site to both maximize power generation and assure economic and environmental feasibility. Typically, turbines are custom designed for to meet site specifics.

There are two general categories of hydraulic turbines: reaction and impulse. Reaction turbines convert the hydraulic head and flow passing by the turbine to rotational energy created by the airfoil shaped blades, whereas impulse turbines turn a runner by absorbing the impact of high velocity jets of water striking the runner buckets. There are many types of turbines, designed for use at sites with differing flows and heads. The three most common types are the Francis, Kaplan, and Pelton turbines (Figure 2-36). The Francis and Kaplan turbines are reaction-type turbines; the Pelton turbine is an impulse-type turbine.

The first modern turbine invented was the Francis turbine, which is used at sites with medium heads and flows. Francis turbines are high efficiency, allowing them to be used for a wide range of heads (from 10 meters to 600 meters). These turbines are usually customized for each site and can be configured either vertically or horizontally. Francis turbines also typically have adjustable wicket gates, which guide flow to the turbine runner in an optimized manner.

In a Kaplan turbine, both the blades and the wicket gates are adjustable. This unique adaptability allows for consistently high efficiencies over a range of flows and heads. In the 100 years since the invention of the Kaplan, a variety of configurations of the turbine have been developed, including the Z, S, pit, vertical, and bulb turbines. Each variation of the Kaplan turbine can be double regulated, meaning the turbine adjusts its runner blades and wicket gates to regulate turbine output for changing water conditions.

The Pelton turbine is best for high head sites and lower flow rates, such as in the mountains. A number of jets (1–6) direct water at high velocity towards the turbine buckets, causing the turbine to spin in air.

The primary factors critical for turbine selections are:

1. Site-specific considerations, such as available head, available flow rate, derived flow duration curves, site conditions, and environmental considerations;
2. Reliability and safety, which includes the turbine equipment as well as its operation and maintenance in order to prevent uncontrolled releases and possible mechanical issues; and



Photo credit: Mavel

**Figure 2-36.** Examples of Francis, Pelton, and Kaplan turbines

3. Economic feasibility, which will depend on turbine price, turbine performance, and civil structures requirement.

Turbine technology has evolved due to advanced computer-based design, analysis, manufacturing, and control methodology. Performance advancements include increased operating efficiency, effective control of cavitation as a wear mechanism, and improved

operating range, operational quality (smoothness), and reliability. For waters with high levels of silt, special turbine designs have been developed to minimize erosion of components. Advanced turbine designs can also incorporate features that enhance environmental conditions, which can lead to improvements in fish passage survival and increases in dissolved oxygen levels in water flowing through the turbines. Significant capital investment toward modernizing and upgrading the fleet is consistently taking place, leaving potential for better use of water for power at existing dams and hydropower sites [2].

Many of the large international companies that manufacture turbines have subsidiaries which are adapting the efficient hydraulic designs of bigger turbines to cost-effective manufacturing, packaging, and installation. These solutions are being implemented in the small hydropower market, resulting in turbine systems that are affordable, efficient, reliable, and easy to install. For example, the vertical micro Pelton turbine applies the concept of a typical Pelton turbine and implements composite runner buckets into a package-type generating unit for small rivers with relatively low discharge and high head [211].

Innovative turbine technologies for small-scale hydropower have entered the market. Archimedes' screw turbines, for example, are becoming increasingly popular in low-scale hydropower. Screw turbines are used on low head/high flow sites, and can produce 5–500 kW of electric power. Due to their low rotational speed and wide diameters that prevent pressure buildup, screws allow better fish to pass downstream than for conventional turbine. Additional small hydropower (<10MW) turbine technologies were identified by the Small Scale Hydro Annex Task Force of the International Energy Agency (IEA).<sup>67</sup>

Research on additive manufacturing techniques holds promise for fast and efficient production of modular structures and turbine components. The term “modular” refers to precast, pre-assembled, and/or standardized components that would otherwise be site customized in traditional hydropower design. Additive manufacturing of modular components has the potential to reduce time and costs associated with fabrication and installation. Furthermore, composite materials used in additive manufacturing have the ability to make turbine components lighter and add a variety of properties, such as increasing material strength.

### **Electrical Components**

As water passes through turbines, the energy from the moving water is converted to a usable form, electrical energy. This section highlights the electrical components responsible for this conversion. Local conditions and the characteristics of the electricity grid are key factors in selection of the major electrical components for a particular hydropower facility. To make successful design decisions, developers must address several questions, including: What is the expected dependable power output capacity from the project, expressed over a 12-month water cycle and the expected ambient temperature? Will any local load service (disconnected from the main grid) be required? What type and magnitude of faults on the local grid will the generator need to be protected from, and are these expected to change over time? Will grid restoration by the generator be required? What method (dispatcher controlled, local operator) and requirement (start-on-demand, spinning reserve) will be needed for generator load response?

**Generators.** Generators connect to the hydraulic turbine and are used to convert the mechanical torque of the rotating waterwheel to electrical power. All large hydropower generators connect directly to the turbine shaft and thus have the same rotational speed as the turbine. Two types of generators are commonly used at hydropower plants: synchronous and induction. Virtually all hydropower generators are the synchronous type, where the generated frequency is synchronized with the rotor speed. Synchronous generators consist of a stator winding, field winding, and bearings for mechanical stability. The typical field winding of a synchronous generator is arranged on a series of poles around the periphery of the rotor and energized from a DC voltage source provided by an exciter.

Induction generators differ from synchronous generators in that the voltage frequency is regulated by the power system to which the induction generator is connected. Induction generators require reactive support from the grid and are thus more commonly used in locations with grid interconnections that do not require the machines to supply voltage support or black start. In cases where there is no grid interconnection, such as in rural distribution systems, induction generators can use step-up banks and distribution circuits to provide this reactive support.

67. These innovative technologies can be reviewed in more detail on the Small Hydro International Gateway of the IEA Small Scale Hydropower Task Force [211].

**Exciters.** Exciters supply the DC power necessary to energize the field windings of synchronous generators, as well as to control the generator voltage and reactive power to ensure stable operation of the power system.

Most modern generators use a static excitation system, while high-speed machines will often use a brushless exciter. In a static exciter, all components are stationary and the DC power results from the generator output itself. Brushless exciters are a form of rotating exciters where a rectifier (responsible for converting AC to DC) is mounted on a shaft that rotates to transfer the DC power to the generator field.

**Step-up Transformers.** Transformers are used in virtually all hydropower applications to step up (increase) the generator output voltage to the grid voltage; therefore, these components are the primary link between the power facility and the transmission network.

Mineral oil is commonly used for insulation in generator step-up transformers. Care needs to be taken to prevent accidental discharge of the fluid into waterways by using oil confinement techniques. As an alternative to mineral oil, insulating fluid derived from renewable vegetable oils can also be used to provide improved fire safety and environmental benefits.

**Advancements in Research and Design of Electrical Components.** Small, low-head hydropower projects have historically relied either on low efficiency induction generators that usually require some type of speed increaser or a synchronous generator. Both induction and synchronous generators have efficiency problems, since they operate at fixed speeds, while turbines need to operate at varying speeds at different heads to remain efficient. Variable-speed Permanent Magnet Generators (PMGs) offer higher efficiency over the entire range of optimum turbine speeds. Permanent Magnet Generators were developed for the wind industry, but are also being adapted and introduced into the small hydropower market.

The hydropower industry is increasingly examining ways to optimize the response of the excitation system to improve system stability under various types of disturbances. Excitation controls have historically been calibrated to respond to an expected system configuration and load flow, which is constantly changing. Industry is using new control techniques with neural

network topology and fuzzy logic, a technique used for solving problems using pattern recognition of trained data sets, to optimize controller response to changing system conditions. Such optimizations will allow the system to operate more efficiently without compromising safe margins of system stability.

Sulfur-hexafluoride ( $SF_6$ ) is being used as an alternative to insulating fluid, and custom insulation systems with temperature ratings to Class H<sup>68</sup> (180 degrees Centigrade total temperature) have also been developed. These custom systems allow self-cooled installations for sites with high ambient temperature. Industry is also designing shell form three-phase transformers that can be shipped in four disassembled packages. This allows for remote locations that would otherwise incur a cost penalty for use of single-phase tanks for a generator step-up transformer to use a three-phase installation.

### Governors

The speed governor is responsible for two critical functions in a hydropower facility. First, it controls the speed of the turbine-generator unit during start-up and shutdown, and automatically increases or decreases turbine output when the unit is on line in order to respond to grid frequency fluctuations (“grid responsiveness”). Second, it protects the power facility’s civil and mechanical structures by controlling the opening and closing times of the wicket gate to limit under-pressure on start-up and over-pressure on shut-down, respectively.

Governor type refers to the methodology involved in detecting unit speed, comparing it to a reference setpoint, and producing an error signal that is transmitted to the pilot control section of the hydraulic power unit, which produces the actual change in servomotor (or wicket gate) position and unit speed/frequency. All hydropower governors operate in a closed-loop manner, meaning they must have real-time feedback of both servomotor position and unit speed in order to perform adequately. All hydropower governor types perform the same primary functions and have similar sensitivity to speed and frequency changes. There are three primary governor types—mechanical, analog, and digital. The following descriptions highlight speed sensing in each governor type and identify similarities among the types:

68. The insulation rating is the maximum allowable winding temperature of a transformer. Insulation systems are rated by standard National Electrical Manufacturers Association classifications according to maximum allowable operating temperatures. Class H is the highest insulation class, with a maximum winding temperature of 180 degrees C.

- **Mechanical Governor:** Speed sensing is done using a Permanent Magnet Generator mechanically connected to the generator shaft, or, in some cases, by a Potential Transformer electrically wired to the generator stator. Some older units still have flyball speed detection governor. When actual speed deviates from the speed setpoint, the rod is moved up or down, which in turn causes the downstream governor mechanisms to process the error and produce a corrective hydraulic output from the pilot valve.
- **Analog Governor:** Speed sensing is done using a pair of magnetic pick-ups, which produce an AC signal of varying frequency. Electronic modules in the governor compare the actual speed with the speed setpoint and develop a corrective hydraulic output from the pilot valve.
- **Digital Governor:** Speed sensing is done using a Potential Transformer electrically wired to the generator stator, and/or a pair of magnetic pick-ups that produce an AC signal of varying frequency. Electronic modules in the governor compare the actual speed(s) with the speed setpoint and develop a corrective hydraulic output from the pilot valve.

Though mechanical governors are the dominant type of governors in service at hydropower plants, they are no longer manufactured due to their high cost. Analog governors have more functionality over mechanical governors but still have more hardware components than a modern digital governor [212]. As a result, digital governors—with their lower cost and versatility through software programmability—are the default governors for new installations or replacements. The key factors in governor selection relate to the location of the software algorithms (whether they are standalone controllers or integrated into a larger unit/plant controller) and the arrangement of the feedback devices to the controllers (whether they are direct-wired to the controller or wired to a remote input/output module that communicates to the controller indirectly over a plant communication network). Critical parameters like speed signals and position feedback signals must be direct-wired to eliminate signal latency and ensure that the governor algorithms are working with the most current speed, position, and turbine output data.

The underlying algorithms (known as Proportional Integral Derivative, or PID) that manage the response of a digital governor to speed and frequency deviations have remained largely unchanged for 50 years.

Original equipment manufacturers and third-party governor providers typically supply setpoint algorithms that provide similar improvements in governor response to on-line setpoint changes. Other advances to increase the availability of digital governors are redundant speed sensing, position sensing, electrohydraulic control valves, power supplies, and programmable logic controller input/output modules.

### *Instrumentation, Controls, and Monitoring*

Instrumentation, Controls, and Monitoring (ICM) provide hydropower facility operators the ability to supervise proper operation of equipment. ICM functions like a “virtual” operator, allowing for the starting of generators or investigation of plant conditions without the delay of waiting for a roving operator. ICM allows operator responsibilities to be automated to a greater or lesser extent, depending on the need to attend to other plants or other process requirements (e.g., river flow control). For facilities controlled from a dispatch center, ICM provides remote capability to perform equipment supervision that would normally only be possible locally.

Programmable logic controllers, Supervisory Control and Data Acquisition (SCADA), and Distributed Control Systems each represent particular digital computer-based implementations of ICM. Programmable logic controllers are industrial control platforms adapted to specific machine control requirements of hydropower facilities. Programmable logic controllers provide distributed controllers at the hydropower facility, allowing control actions to be determined rapidly in response to local conditions, independent of operator intervention or communication with the main watershed controller.

SCADA systems provide for directed control of operations (starting, stopping, load changing) from a remote location (the master station) via operator actions. Alarm reporting and response are design features of SCADA systems that allow the operator to directly recover from abnormal plant conditions that might otherwise lead to generator shutdown. Other than automatic water flow control algorithms at the master station, operations via a SCADA system are manually controlled, requiring nearly continuous attendance by the operator at the master control console.

Distributed Control Systems are locally networked controllers, providing process- or machine-specific control capability along with remote communications



and data archiving. Typical applications would include a multiple generator powerhouse with a local control room.

ICM systems were originally designed for attended (manned) hydropower facilities operating under local control. Remote visibility was typically not a design requirement for these ICM installations, meaning that even visibility in the plant control room may not have been available. Remote control actions in these settings were communicated via voice commands from a central control center and executed by the local operator. Critical variables that could normally be observed by a local operator should be considered when remote control capability is being added to hydropower facilities originally designed for local control in order to properly monitor plant performance and condition. Remote control may be desired as a means to allow centralization of operations personnel and dispatch functions. In cases where local control will still be allowed, coordination of controls design is critical for safety of personnel, equipment, and the public.

ICM systems for remote and automatic dispatch of hydropower generators must provide key safety features to prevent development of hazardous conditions for personnel, equipment, or water conveyance features. The local mode of control must prevent any remote operation of equipment, and local hardwired protective control functions cannot be disabled by the remote ICM system without creating a continuous alarm notification of the abnormal condition. The control system must also be designed to respond appropriately to avoid or reduce damage despite single component failures, considering the range of normal, abnormal, and emergency modes of operation. Appropriate ergonomic and cognitive features must be included in the ICM system design to avoid alarm fatigue and visual strain for personnel over 12-hour shifts.

Advances in research and design of instrumentation, monitoring, and control equipment include “Plug-and-Play” controls, and development and implementation of Generic Data Acquisition and Control Systems. Generic Data Acquisition and Control Systems are a computer-based industrial control system that automates operation of a system of devices used to control dispersed assets. The Generic Data Acquisition and Control Systems product contains commonly available building blocks for constructing scalable systems, and specializations for hydropower optimization and water

control applications. Solar and wind energy both make increasing use of standardized equipment referred to as “plug-and-play.” This standardization and ease of use can simplify and accelerate installations. Small, mini, and micro hydropower systems can benefit from this same approach. Equipment for each small hydropower system is historically custom designed. A standard control package that “plugs” into specific generators could make installation simpler, even for less experienced developers. Plug-and-play controls can be integrated into standardized modular turbine-generator systems for small hydropower, resulting in easier and less expensive project implementation.

### 2.5.3 Computational Tools for Hydropower

Advanced computational technologies are used by developers, engineers, and researchers in a wide variety of hydropower applications. These include hydraulic design, river forecasting, water quality modeling, and water use optimization. Often, super computers are used to run the models.

#### *Hydraulic Design*

Hydraulic design for hydropower projects encompasses a variety of components such as turbines, spillways, intakes, draft tubes, outflow conduits, and fish passage systems. The primary design tools used by the hydropower industry are laboratory reduced-scale physical models and computational models. Laboratory models are based on alignment of laboratory measured quantities and the corresponding values in the full-scale system. Hydraulic models (both laboratory and numerical) are generally used to simulate conditions for three distinct hydropower activities: environmental enhancement, dam operation, and turbine design and optimization. Beyond the traditional hydraulic design applications, research has been directed towards using hydraulic models to quantify and identify measures to reduce fish mortality rates [219]. Computational fluid dynamics models use numerical methods to represent the physics of fluid in motion in the complex water systems of a hydropower facility. Rapid development and increased computing power have led to increased use of computational fluid dynamics models, which are commonly used by the hydropower industry as a first step in the investigative and design processes (Text Box 2-8).



Text Box 2-8.

### Biological Performance Assessment Toolset

DOE has developed a method for estimating the risk of fish passage through hydropower turbines called the Biological Performance Assessment (BioPA) Toolset. BioPA uses computational fluid dynamics simulations of turbine designs to quantify the exposure of passing fish to four main stressors: nadir pressure, shear, turbulence, and blade strike. The Toolset calculates the probability of fish injury and combines these results with laboratory stress studies to produce a set of scores. These objective metrics can be used to compare relative performance between competing turbines or to refine a design, resulting in an increased number of fish successfully passing through turbines (see <http://availabletechnologies.pnnl.gov/technology.asp?id=373>).

### River Forecasting, Water Quality, and Water Use Optimization

Hydropower operators release water in a way that optimizes power generation while balancing economic, social, and environmental objectives. A variety of analytical tools have been developed to help operators in planning and scheduling on a spatial and temporal basis. River system real-time scheduling modeling tools have been developed for operational decision making, responsive forecasting, system optimization, and long-term resource planning. These real-time scheduling tools allow the user to compare several planning alternatives by modeling hydrologic and hydraulic processes, hydropower production, and water quality parameters such as dissolved oxygen, total dissolved gas, and temperature, among other factors. Hydrodynamic and water quality and optimization models capable of simulating and predicting how watershed management practices might affect the water quality of a reservoir. These models use several assumptions and approximations to simulate hydrodynamics and transport to predict variables such as water surface elevations, velocities, temperatures, and a number of water quality constituents.

In 2013, DOE funded a 3-year project to develop a set of tools to simultaneously optimize water management, energy generation, and environmental benefits from improved hydropower operations and planning while maintaining institutional water delivery requirements. The Water Use Optimization Toolset, or WUOT,<sup>69</sup> is a suite of advanced analytical tools to simulate key factors affecting hydropower operations, including water availability, short- and long-term water and power demands, and environmental performance. Instead of simply enforcing prescribed environmental requirements, the WUOT can discover new modes of operation that actually improve environmental performance without sacrificing water or power economics. The WUOT has been specifically designed for daily use by hydropower planners, schedulers, and dispatchers to assist in market, dispatch, and operational decisions.

### 2.5.4 Environmental Protection and Enhancement Technologies

Hydropower can have potential environmental impacts. Two of the main concerns are water quality and fish passage. Protection and enhancement technologies have been developed to address these concerns.

#### Water Quality

Water quality and stream flows in waterways are typically affected by reservoirs that impound water for various uses, including hydropower generation. The effects of hydropower projects on water quality are site-specific and are an important consideration in the FERC relicensing process, as well as for State 401 Water Quality Certificates, which are required in order to prevent potential pollutant discharges to waters of the United States. Primary water quality concerns are ensuring adequate dissolved oxygen levels, water temperature, and minimum and/or environmental (water quantity and quality) flows for aquatic life.

Many environmental mitigation technologies are employed at key points in a hydropower facility upstream of a hydropower dam, temperature control devices are used for selective withdrawal of cold water for downstream fisheries, Garton pumps are used to push oxygenated water down to the turbine penstock intakes for aeration of releases, and line diffusers are used to increase the oxygen of water

69. Available on the Argonne National Laboratory website (<http://www.anl.gov/energy-systems/project/water-use-optimization-toolset-conventional-hydropower-energy-and>).

in the forebay (i.e. the portion of a reservoir that is immediately upstream from a dam). At a hydropower dam, auto-venting turbines can add oxygen to hydropower releases; and mixing of warm water with cold water bypass releases can be used to provide a cooler downstream environment year-round. Aeration of turbine flows in the draft tubes is the one technology used to improve dissolved oxygen. Downstream of a hydropower dam, labyrinth weirs<sup>70</sup> can be used to increase oxygen concentrations in hydropower releases and to provide more steady-state flow conditions for the environment.

Considering the multitude of turbine system designs and the variation in water quality and hydrology from year to year, selecting the best approaches for water quality management at a hydropower facility can be challenging. Consequently, reservoir water quality models are commonly employed to simulate reservoir oxygenation using techniques such as oxygen diffuser systems, surface aeration, draft tube aeration, weir aeration, and forebay surface water pumps. Model output is used in combination with water quality management strategies to determine the most appropriate site-specific environmental technologies. Site-specific characteristics that may impact the TDG exchange at a hydropower facility include structural features of the spillway and stilling basin. The TDG exchange associated with spillway releases has been found to vary markedly from regulating outlet releases [213]. The interaction of highly aerated spillway flows with powerhouse releases may also play a prominent role in establishing the net TDG exchange in hydropower dam discharges.

### **Fish Passage**

Safe passage of fishes through hydropower dams has been a topic of interest for decades. There have been numerous innovations across a broad range of technologies for reducing, evaluating, and monitoring the impacts of fish passage structures on fishes, including:

- **Upstream passage technologies.** Fishways for upstream passage have been around since the 17th century. The construction of hydropower facilities on the Columbia River in the 1930s accelerated the establishment of standards for entrance and

Text Box 2-9.

### **Advancements in Water Quality Technologies**

Considerable effort has been devoted to addressing concerns for water quality standards and minimum flows. The following technologies have been developed or enhanced and applied at hydropower plants operating since 1990:

- Draft tube aeration added to turbine hub, blades or draft tube wall
- Surface water pumps that increase dissolved oxygen in hydropower releases
- Skimmer devices (e.g., skimmer curtains, skimmer walls, trashrack plates)
- Oxygen diffusers using porous hose to increase dissolved oxygen and/or fish habitat in reservoirs, and to reduce anoxic products (e.g., hydrogen sulfide, ammonia, methane)
- Aerating weirs (labyrinth, infuser) for tailwater aeration
- Upwelling air diffusers to reduce temperature in near-surface turbine releases
- Compressed air added to draft tube
- Pratt Cone valves
- Selective operations of turbine units that can increase tailwater dissolved oxygen

exit locations, and attraction flows and velocities. Technologies for upstream passage are developed, and considered to be well-understood. On-going research continues in the United States and internationally to improve fish passage technologies for all fish species and under different river systems. There are six main types of fishways: 1) pool and weir fishway; 2) baffle fishway; 3) mechanized fish elevator; 4) rock-ramp fishway; 5) vertical-slot fishway; and 6) siphon fishway. There is no single general solution for designing upstream fish passageways. Effective fish passage design for a

70. A weir is a barrier built across a river or stream to alter its flow characteristics by raising or diverting water. Aerating weirs, such as the labyrinth type with its repetitive “W” shape, are specially designed to add oxygen to the water through air entrainment and increased oxygen transfer across the entrained bubbles.

specific site requires thorough understanding of site characteristics and fish population and fish behavior. Other technologies are being developed and tested around the world.

- **Downstream passage technologies.** There are six main technologies: 1) behavioral guidance devices; 2) physical barriers; 3) collection systems; 4) diversion systems; 5) surface flow outlets; and 6) fish-friendly turbines. Behavioral guidance devices use the avoidance response to external stimuli or natural behavior patterns to repel or attract fish. The most common of these are lights, electric fields, sound, air bubble curtains, water jet curtains, or a combination of these. Physical barriers are usually used with low water velocities; common types include barrier nets, porous dikes, bar racks, and infiltration intakes. Common collection systems include intake screens, fish pumps, and

other bypass systems; while common fish diversion systems include angled screens, louvers/angled bar racks, Eicher screens, modular inclined screens, angled rotary drum screens, inclined plane screens, and guidance walls. Surface flow outlets include ice and trash sluiceways and spillway weirs. Fish-friendly turbines, such as the Alden turbine (Figure 2-37), have been specifically designed to address concerns about downstream fish passage. While not a passage technology per se, another common method to protect downstream migrant fishes is voluntary spill. Similar to upstream passage, there is no single solution for designing downstream fish passage. Effective design for a specific site requires thorough understanding of site characteristics and fish behavior, as well as good communication between engineers and biologists.

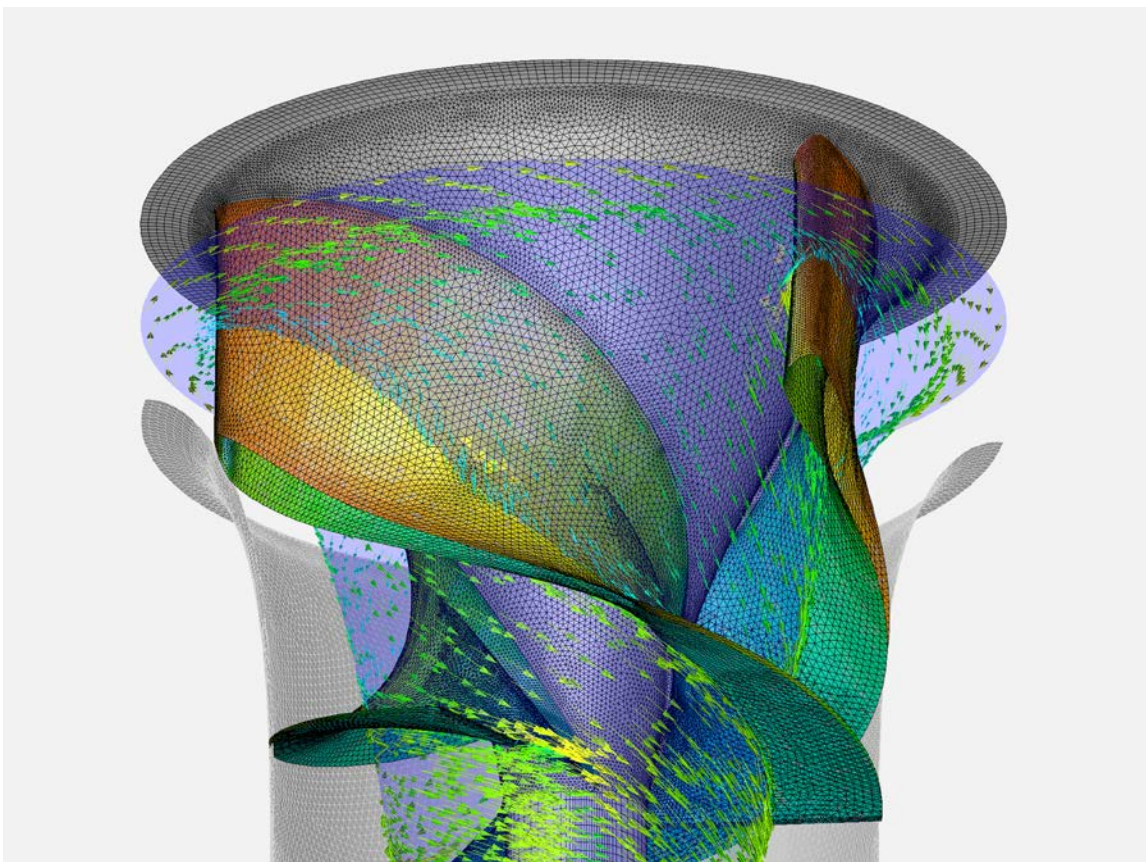

Source: Department of Energy [214]

**Figure 2-37.** A computational fluid dynamics model simulation of the Alden Fish-Friendly Turbine

- **No-Dam Hydro:** Future hydropower development could be “no-dam hydropower,” with a compact hydropower concept that would be installed either in one section of a river or adjacent to it, using only a portion of the river flow with fish diversion devices. This concept is still in the research and development stage. In 2012, Snohomish County (Washington) Public Utilities District received a preliminary permit from FERC to study and assess the potential of a 30-MW hydropower project on the South Fork Skykomish River that would require no dam, weir, or river barriers. This design is expected to reduce construction costs by \$10 million and minimize environmental impact [215].

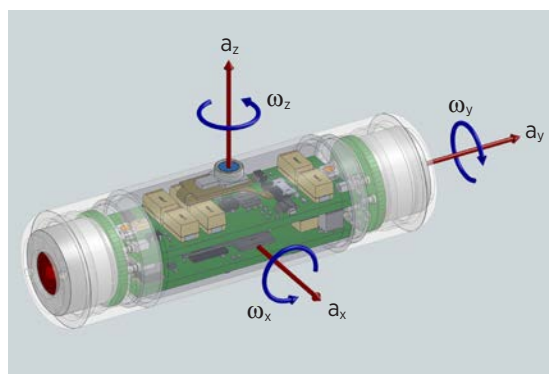

Source: Pacific Northwest National Laboratory

**Figure 2-38.** Three-dimensional drawing of a fish sensor device (dimensions: 89.9 × 24.5 mm)

Text Box 2-10.

### Mitigation of Environmental Conditions

Dams can have potentially adverse ecological impacts on fishes, aquatic wildlife, and botanical resources. Large impoundments impact the ability of aquatic organisms to move upstream and downstream within a river system, which may lead to population fragmentation and changes of spawning areas and habitats. Advancements in technology, however, have helped to mitigate these impacts.

Low dissolved oxygen is a common problem in reservoirs in the southern United States. At many existing hydropower facilities, the turbine intakes are far below the reservoir surface, where dissolved oxygen levels may be as low as 0 milligram per liter. When this water passes through the turbines and is discharged into the tailrace downstream of the facility, these low dissolved oxygen levels can have an adverse effect on water quality and aquatic life. Aerating turbines are an effective solution to this problem. Duke Energy, for example, demonstrated the opportunity to improve dissolved oxygen levels in water downstream from the Bridgewater Project in North Carolina. This mitigation was achieved through the installation of aerating turbines at a new powerhouse.

The Penobscot River Restoration Project consisted of the removal of two dams in the Penobscot River, and bypass addition of a third dam, which resulted in improved access to nearly 1,000 miles of habitat for eleven endangered species of sea-run fishes in Maine. Improved fish passage at four remaining dams and increased renewable generation at six means that these ecological benefits will be realized while maintaining or even increasing energy production.

In 2013, Grant County Public Utility District completed the installation of 10 new fish-friendly turbines at its existing Wanapum Dam hydropower facility to boost juvenile salmon survival rates and increase renewable energy generation by an average of 3.3%. The utility also installed a surface flow outlet, consisting of a 290-foot concrete chute, to ensure that young salmon migrating downstream to the Pacific Ocean can pass the dam unobstructed. This route achieves dam passage survival rates of greater than 98% for juvenile sockeye salmon and 99% for juvenile steelhead.



## 2.5.5 Costs and Equipment Optimization

Opportunities exist to reduce costs across a spectrum of hydropower equipment, ranging from small hydropower to large hydropower equipment, and components to support flexibility. These potential cost reductions in equipment and civil structures are a factor in expanding hydropower and keeping it competitively priced in the energy market. Small hydropower has high potential for expansion; however, these projects are typically customized for each application due to the numerous relevant variables in their application [216]. Head can vary across small hydropower projects, necessitating a range of different turbine types [212]. More modular equipment allows different turbine-generator packages to be available for a more inclusive variety of projects, and economies of scale are achieved by reusing the same turbine-generator design for different plant conditions. Adding variable-speed drives to generators at existing or new hydroelectric plants can result in increased power output. The speed of the generator adjusts to the speed of the turbine and operates at different head, thus keeping high generating efficiency without adverse effects on the electric grid interconnection or generation plant.

Hydropower facility operators monitor each piece of equipment and system in their facilities closely and typically delay replacing equipment as long as they are not experiencing recurrent failures or forced outages (non-scheduled outage). Since equipment replacement requires long lead time, however, factories strive to fabricate equipment quickly and reduce the cost of associated facility downtime. Orders may be placed based on paying a premium to shorten equipment replacement schedule, or based on the shortest firm delivery and assembly schedule. This can be done by shortening the design time and speeding up material deliveries necessary for emergency fabrications. While doing so can increase the cost of fabrication and installation, it can also generate larger net savings if a facility can be returned to revenue-producing energy generation more quickly.

Operators can have more operating flexibility, which can be translated in potential cost savings, if facility equipment is retrofitted to adjust to changing operating conditions. Due to renewable penetration, such as wind and solar, and the associated load following, hydropower and PSH operations are generally performing more starts and stops. This results in increased wear and shortens periods between major maintenance. Environmental requirements to meet river system targets such as water temperature, dissolved oxygen, minimum flow releases, and others force turbines to operate at different flows or heads. This results in rougher hydraulic operation and efficiencies lower than that for which systems are designed. These changes lead to increased maintenance and forced outages.

Grid interconnection is also a vital aspect in development of hydropower. Factors that must be considered include the market into which the generation will be sold, interconnection voltage, number of interconnecting lines, the magnitude of the local load service on the distribution network, and the ability of the system to reliably absorb the generation. A close match between generation and load should be maintained to ensure no voltage regulation issues arise. A lower voltage interconnection results in a lower cost of substation and transmission line. The location and size of the facility within the interconnected transmission system will determine the level of improvements and, consequently, costs to bring the generating plant on-line. These interconnection costs can be large enough to affect the viability of a hydropower facility project. Grid interconnection is discussed in more detail in Section 2.2.

### *Impact of Cost Uncertainty on Development and Financing*

On all hydropower developments, whether for a new facility or for an addition or refurbishment at an existing facility, the owners, developers, and financiers are concerned about net revenues as well as estimated costs vs. final costs. Investors need assurance that project debt payments will be paid and a project profit that meets their objectives will result. In early planning and feasibility studies, it is critical



to properly estimate the project tariff and revenue, and to identify the interconnection cost. Projects that obtain higher tariffs can reduce owner or developer concerns and uncertainty regarding project revenue.

As noted previously, project cost estimators and financiers assign risk to each element of a hydropower cost estimate. Hydropower equipment costs can vary widely, and cost estimators often seek to obtain equipment bid prices as early as possible to reduce risk. Licensing or environmental study costs are not as predictable and these processes can take longer than planned, so costs may increase until the licensing is completed and required environmental mitigation is implemented. Such costs are often viewed as having moderate risk due to schedule and scope uncertainty, while below ground or underground construction such as that needed for hydropower facilities is often viewed as moderate to high risk due to vagaries of ground conditions present over large sites and within deep excavations.

Financiers attempt to mitigate project uncertainty through due diligence and the establishment of project requirements. These steps allow financiers to manage project construction-related expenditures and operating revenues. There are many techniques and methodologies used to remove uncertainty and risk from revenue prediction, construction cost estimates, and project construction schedules. If a project does not have adequate study development and site investigations, report documentation, a cost estimate with contingency for unknowns and risk items, a realistic construction schedule, predictable O&M costs, and comprehensible project tariffs with associated revenue predictions, an owner/developer will not invest equity and a financier will not finance the project.

### **Existing Equipment Optimization**

About 95% of the existing U.S. fleet of hydropower facilities was designed and built before 1995, with about 52% of plants built prior to 1965 and some using equipment that was designed more than 80 years ago [274]. Depending on the extent of maintenance programs, the equipment and water conveyance structures have likely degraded in ways that decrease energy produced compared to the original design. Many facilities have exhausted much of their useful life [217].

Hydropower design and manufacturing technology has advanced since the 1990s. Modern technologies use tools such as computer-aided flow analysis and structural analysis, computerized numerical control manufacturing, and advancements in materials science to produce hydropower component designs that can modernize an existing facility and improve compatibility with the surrounding aquatic environment. Incremental percentage increases in power generation from the same quantity of water, and higher energy capacities from the same powerhouse volume are commonly realized. It is typical to see plants realize operational efficiency improvements of 1% to 3%, and occasionally up to 10%, when modernizing older equipment. Unit capacity increases following upgrades have ranged from 5% to 15%, sometimes rising above 20% depending on the scope of the upgrade [218]. While energy generation improvements are related to efficiency and unit capacity improvements, they depend on the overall hydropower facility head and flow availability [212].

With the addition of updated control equipment and monitoring, units and powerhouses can operate in an informed and optimized configuration; the goal is to decrease the amount of water needed to produce a unit of energy. Agencies such as the Corps, Reclamation, TVA, and BPA are implementing efficiency programs that identify, design, and implement near real-time improvements on the hydropower system. The improvements fall into two categories: (1) making individual generating units more efficient by testing and tuning the operating parameters, improving measurement methods, and implementing controls to monitor the operations, and (2) operating generating units efficiently at a given facility through determination of the optimum number of units and configurations to be operated and the specific units that should be loaded [212].

The hydropower industry has invested at least \$6 billion since 2005 in refurbishments, replacements, and upgrades to existing hydropower plants, with nonfederal owners spending more per installed kW than federal owners. These investments have ranged from replacing bearings to rebuilding dams. Most of the hydropower capacity additions in the United States have come from unit upgrades or additions to existing projects [2].

## 2.5.6 Technology Research and Design

Research and development are necessary to improve reliability, safety, efficiency, O&M, rehabilitation, and modernization of existing hydropower infrastructure.

Research into technologies for windings, including insulation systems and wedging systems, and into safety issues such as acceptable noise would help hydropower facility owners implement the most innovative technologies and continuously improve refurbishment outcomes. Research on transformers has focused on examining alternative insulation fluids that can improve personal safety and reduce environmental impact, such as ester oil and SF<sub>6</sub> gas. Guidelines for outage planning and management strategies, and their associated costs and saving opportunities, can help utilities understand different approaches and how those approaches might benefit utility customers. New methods for relay schemes or even new protection devices might be useful to help mitigate the often damaging results of arc flash. Research to identify the most common safety concerns and how to mitigate them in hydropower facilities could also prove valuable.

Through optimization and modernization, technology developed since the early 1990s is providing new opportunities for cost-effective energy production at nearly all plants. A comparison of optimization results might provide valuable information on what technology is available, as would research into the data that support these systems, such as performance curves, flow measurements, and cost. The industry could also benefit from cost-benefit analyses of modernizing existing hydropower facilities. A “smart” design process may be used to address facility life extension, water use optimization for energy production, O&M cost reductions, and environmental improvements, among others.

Finally, with many regions being asked to integrate variable renewable generation technologies such as solar and wind, an examination of operational changes to existing infrastructure might provide alternative solutions to building new infrastructure and another way to optimize and use hydropower units to produce additional revenue.

## 2.5.7 Trends and Opportunities

Trends and opportunities in Design, Infrastructure, and Technology include:

- Development of the next-generation hydropower technologies, through advances in research and design of dams that can help reduce the cost of civil structures and minimize construction time—modular and segmental design; precast systems; glass steel fiber reinforced concrete; smart concrete technology; rock-bolted underpinning system.
- Enhancement of the environmental performance of new and existing hydropower technologies, through activities such as adaptation of power efficient and fish-friendly hydraulic designs for cost-effective manufacture and installation for hydropower facilities.
- Comparison of optimization tools, and results and quantification of the benefits and/or added value to provide information on available technology; and research into the data that support these systems, such as performance curves, flow measurements, and cost.
- Implementation of cost-benefit analyses of modernizing existing hydropower facilities should benefit the hydropower community. A process of “smart” design may be conducted to address facility life extension, water use optimization for energy production, O&M cost reductions, and environmental improvements, among other issues.
- Examination of operational changes to existing infrastructure, which should provide alternative solutions to building new infrastructure.
- Addition of updated control equipment and monitoring, which can allow units and powerhouses to operate in an optimized configuration, thereby decreasing the amount of water needed to produce a unit of energy.
- Validation of the power performance and reliability of new hydropower technologies as well as assessment of the role and value of the federal hydropower fleet.

## 2.6 Operations and Maintenance

Hydropower O&M comprises the systematic activities that owner/operators undertake to maintain facility reliability to generate electricity. Facility operations involve selecting the appropriate generating units and bringing those units online; monitoring and controlling water releases and power generation; and safely shutting down units. Reliable operations cannot occur without proper, periodic maintenance of the components of hydropower facilities. Hydropower owner/operators maintain safety and reliability, and achieve operational objectives, by establishing hourly, daily, and weekly, and longer-term periodic operational procedures and best practices. Successful O&M is the achievement of pre-determined performance targets that are consistent with the overarching and established energy, environmental, and socio-economic objectives for hydropower facilities. This section details basic O&M practices for hydropower.

### Highlights:

- Ensuring environmental compliance through facility enhancements, modeling of hydrologic cycles, refined operating procedures, and system monitoring is an increasingly important element of O&M.
- Decision making processes at individual plants are closely linked to full river system and power grid operational requirements to coordinate and minimize impacts of O&M activities on system operations.
- Evolving hydropower technologies and implementation strategies enhance operating reliability, flexibility, and responsiveness, thus increasing the market value of hydropower.
- Refinement of O&M methods will support hydropower growth through development of best practices, fleet-wide benchmarking, and improved incorporation of flexibility and environmental mitigation into operations scheduling and planning.

### 2.6.1 The Hydropower O&M Domain and Drivers of Change

Figure 2-39 illustrates hydropower O&M objectives in order of decreasing priority: Safety [of operations], Environmental Support, Reliability, and Maximizing Value and Performance. Hydropower owners employ multiple O&M implementation strategies to achieve these objectives, including models for staffing, control, and maintenance, along with a system of benchmarking and performance assessment, asset management, and a refurbishment strategy. Knowledge transfer and training play a critical role in O&M functions. This fact is especially true with the expected turnover of the workforce due to retirements. Owners typically choose one of several alternative strategies in each of these areas. The subsequent sections discuss these objectives and alternative strategies.

O&M methods are discussed separately in the *Hydropower Vision* for clarity, but this distinction is not always a natural one. Many activities accomplished by facility staff under management systems have related O&M objectives, with an overarching objective to ensure facilities are available to operate safely within environmental constraints and at the lowest cost possible to the benefit of the grid and its customers.

Hydropower O&M activities are evolving in response to multiple drivers of change, including cost reduction; power system reliability and security; ancillary grid services and flexible operation; increasing environmental needs; and decision making amidst uncertainty. O&M practices are intended to serve a range of objectives, detailed here.

#### Safety

Hydropower facilities and dams have specific workforce cautions and are often located in areas used for public access and recreation. One area of focus for hydropower facilities includes safety—dam safety, public safety, and workforce safety.

The recreational use of reservoirs and streams adjacent to hydropower facilities is a benefit provided by all but the most remote or isolated facilities. For non-federal hydropower facilities, the Federal Power Act requires that the regulatory process give equal consideration to developmental and

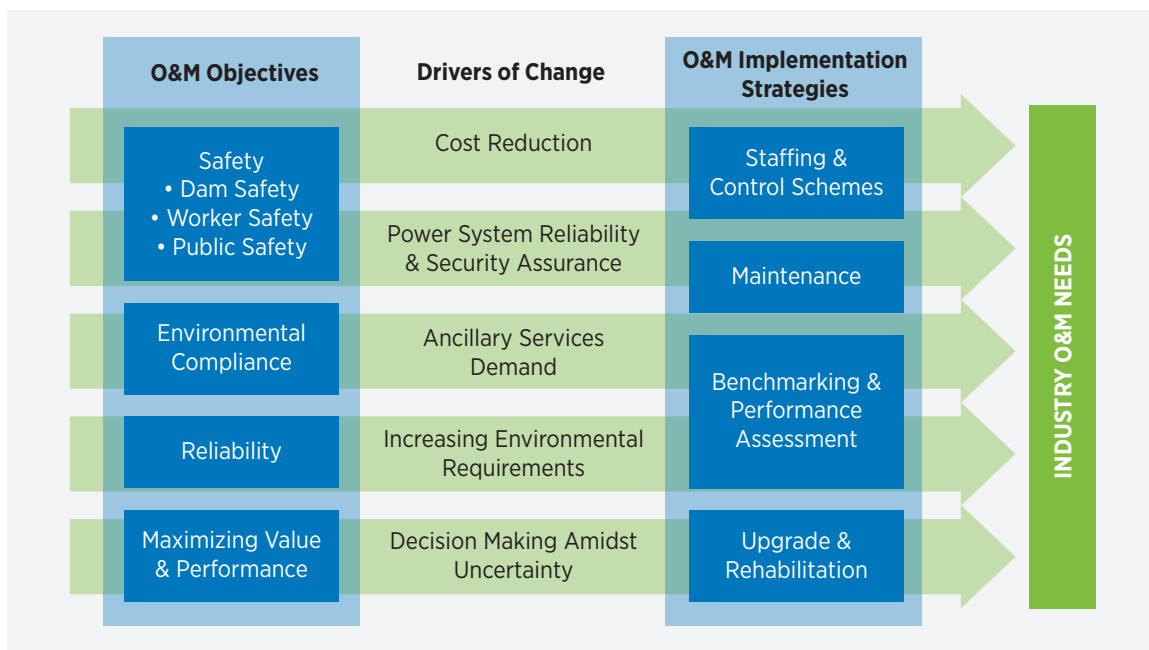

Source: Oak Ridge National Laboratory

**Figure 2-39.** The hydropower operations and maintenance paradigm

non-developmental (e.g., recreational use, protection of historical or cultural sites) values of public water resources. In addition to being a mechanism for facility owners to connect with stakeholders, recreational access may stimulate tourism and economic expenditure that benefits local economies. Over the term of hydropower licenses, non-federal hydropower operators must monitor and report public use associated with each facility and public access area. These operators are also responsible for making improvements and adding amenities or expanded public access, if required. In highly developed areas, these public use facilities may be a local and regional economic driver. Lands adjacent to hydropower reservoirs also tend to be desirable for private and commercial development. Recreational communities, private residential lots, and recreation-related commercial facilities have become fixtures of most reservoirs. The demand for private development needs to be balanced with providing access for reservoir users, including undeveloped natural areas, public access areas, formalized recreation areas, and mixed commercial uses that make each reservoir unique to the surrounding environment. Diligent public safety planning and management ensures owners have shoreline permitting programs

that avoid the creation of public safety hazards (e.g., permitting docks and marinas, ensuring boat launches are appropriately spaced, enforcing local codes for electrical work, monitoring water hazards such as ski courses). Planning for and providing such features can ensure long-term benefits and opportunities for the public and local communities.

Many hydropower facility owners have public outreach programs that include education to schools, environmental groups, and the general public. These programs provide basic information on the hydropower plant's role and integration in the local environment. Proactive Emergency Action Plan training, community outreach, signage, and warning sirens are all mechanisms that can help educate the public about the dangers associated with dams and their aging infrastructure.

After the terrorist attacks of September 11, 2001, hydropower facility owners reviewed the level of public access to hydropower facilities and associated dam structures—many of which were previously open to the public—with regard to possible terrorist attacks. Since hydropower facilities provide support

to the electric transmission grid for energy and specific ancillary and essential reliability services, including system restoration (black start), owners installed security fencing to limit access. Some of the larger hydropower facilities, including those owned by government agencies, also had security forces added.

**Dam Safety.** Dam safety is a consideration at both non-powered dams and hydropower facilities. FERC's Division of Dam Safety and Inspections, along with state dam safety agencies, requires all non-federal dam owners to prioritize the prevention of failure or any unintentional release of water. Instrumentation and monitoring programs are in place as an effort to prevent such events. A dam failure can result in loss of life, property damage, and unplanned expenditures for the facility owner. Aside from the need to maintain the dam structure in a safe condition for public safety in general, the owner would likely be subject to liability claims if the dam were to fail. Regardless of the size or type of entity that owns the dam, the owner has obligations to meet safety rules and will have defined roles for their personnel who support dam safety programs, such as a dam safety operator. Dam failures are most likely to occur for one of five reasons [220]:

- Overtopping caused by water spilling over the top of a dam;
- Piping caused when seepage through a dam is not properly filtered and soil particles continue to progress and form sink holes in the dam;
- Cracking caused by movements like the natural settling of a dam;
- Inadequate maintenance and upkeep; or
- Structural failure of materials used in dam construction.

Hydropower facility owners detect changes in dam structures and prevent failures using comprehensive monitoring plans that provide advanced public notice protocols as defined in each dam's Emergency Action Plan. Dam structures do decline over time, but signs of this deterioration such as seepage, settlement, and cracking are all detectable by routine inspection and monitoring. Common monitoring systems include piezometers to determine water levels in the dam, inclinometers, and other automated systems that provide engineers with data to continually assess the condition of a dam. Dam safety monitoring plans also

include instrumentation and visual inspections. Inspections are essential to the stewardship of dams and associated facilities. FERC conducts periodic inspections of dams and other structures at FERC-licensed non-federal hydropower projects. Federal agencies have similar programs to assure the continued safe operation of federal hydropower infrastructure, dams, and waterworks. Visual inspection usually involves periodic checks, e.g. monthly/weekly checks by operating staff and annual inspections by engineering staff, which help detect unusual conditions such as cracking or piping. FERC-regulated hydropower facilities that are classified as high hazard and significant also include annual inspections by engineering staff from FERC's Division of Dam Safety and Inspections. Other dams are inspected at 3-year intervals. Additional inspections are made and audited by a third-party dam safety expert every five years.

These monitoring programs meet requirements of regulatory agencies, such as FERC's *Engineering Guidelines for the Evaluation of Hydropower Projects*. Dams belonging to investor-owned utilities are under the jurisdiction of FERC and state agencies, while structures owned by the federal government follow requirements in the *Federal Guidelines for Dam Safety*.

Dam owners also have maintenance programs to address abnormal conditions discovered in monitoring observations. For embankments, certain dam structures (i.e., earthen dams), should be covered with grass and shallow-rooted native plants, and regular mowing and maintenance schedules should be maintained. Trees and brush should be removed to facilitate inspection of the embankment and to prevent seepage paths (i.e., piping) due to their root structures [221]. Damage due to erosion, seepage, and cracks should be corrected when detected. For dam spillways, which allow passage of normal water flows, structures should be maintained and control equipment such as cranes, gates, and valves must be fully functional. Key maintenance activities include testing, lubrication, and correction of defects.

**Workforce Safety.** Hydropower facilities contain a number of energized components such as transformers, cables, switchgear, and generators, and the movement of heavy equipment and materials in such facilities is common. The safety of hydropower facility workers is of utmost importance, and owners have developed safety programs and procedures to prevent electrical shock, physical injuries, or death. These



programs also include hazard awareness and safety procedures for water conveyance structures such as open flumes, channels, bulkheads, gates, and tunnels. Included are procedures to train workers about and reduce worker exposure to other hazards present in these facilities from compressed air, confined spaces, falls, material lifts and other dangerous situations. Reclamation has developed an extensive noise reduction program to prevent hearing loss in its facilities.

As industrial safety evolves, new regulations with worker safety requirements are issued to meet newly identified hazards. For example, in 1979, the National Fire Protection Association introduced NFPA 70E, Standard for Electrical Safety in the Workplace, which discusses methods to protect workers from harm due to exposure to electrical systems and devices. In 1995, NFPA 70E was revised to help protect individuals from arc flash dangers. Facility owners have made equipment modifications where possible, placed administrative controls, and provided new personal protective equipment to address the arc flash hazard.

Just as changes in maintenance approaches and safety have impacted hydropower facility owners, so have changes in workforce management. Some facility owners have incorporated human performance practices into their workplace management, e.g., the use of written procedures and checklists; ensuring the understanding of failure modes. Additional changes include the use of a maintenance management system to administer their work force and assets. The prime objective is eliminating equipment failures and accidents due to human error.

### ***Environmental Stewardship in O&M Activities***

Hydropower facilities are located within complex aquatic and terrestrial ecosystems. In the presence of hydropower development and operations, these natural resources must be protected and restored to ensure their health and longevity. These stewardship activities require ongoing effort and expenditures by facility owners, regulators, non-governmental organizations, local governments, Indian tribes, and stakeholders. For facility owners, the environmental stewardship objectives embodied in policies, rules, and laws must be translated into operating procedures and best practices that can be implemented by facility staff and control systems.

Environmental stewardship requirements typically translate into minimum and maximum flow schedules, reservoir and tailwater elevation thresholds and rates of change, limits on the rate of change of flow releases from the facility, and changes in release schedules triggered by water quality conditions or the presence of fish that may be affected by operations. Facility or central staff must maintain environmental monitoring equipment; report monitoring data and analyses to regulatory authorities and to the public; and forecast, measure, and report the extent to which energy and environmental objectives and targets will be met. At the local facility level, these efforts center on monitoring and procedures, while compliance and tradeoff analyses for river systems and multiple facility fleets may be accomplished by dedicated environmental and performance staff.

When hydropower facility or support staff implements environmental stewardship activities, there are two effects on hydropower value. First, stewardship activities have direct costs that contribute to the life cycle and production costs for hydropower facilities. Examples include costs to install and maintain environmental mitigation equipment, perform biological monitoring and field data collection, and purchase bulk liquid oxygen for aeration systems. Second, stewardship activities may engender opportunity costs. For example, the majority of fishways that enable fish passage around dams require water to function. That water does not pass through turbines to generate energy and revenue for a facility owner. Operating spillways so as to route fish around turbines also has an opportunity cost.

A common example of opportunity cost is maintaining minimum flow releases through a facility even when the resulting energy generation is of low value in terms of revenue to the owner. In these cases, the minimum flow requirement has been established for the important objective of sustaining the health of downstream ecosystems, but the minimum flow release operation uses water that could otherwise be released during times of the day when energy prices are highest and would result in greater revenue for the facility owner. However, opportunity costs for minimum flow releases do not always accrue to the facility owner. In times of drought, maintaining minimum flow releases may mean that upstream reservoirs are depleted, with the reduced water surface elevation of those reservoirs resulting in diminished recreational opportunities or riparian habitat.

### Grid Reliability

As discussed in Section 2.1.2.4, NERC is a non-profit corporation that has been certified by FERC to develop mandatory reliability standards in the United States. NERC and its regional reliability entities<sup>71</sup> are charged with enforcement of these requirements. These reliability standards affect power facilities because they set guidelines within which operations must be conducted. Adherence requires documentation of generator capability, as well as testing of the protection circuits, station batteries, and other electrical functions required to maintain the electric grid. It also requires that facility operators respond to directives from transmission operators in order to support grid reliability. Failure to comply with these standards can result in monetary fines. In addition to providing a reliable source of electrical power to the electric grid, hydropower plants are ideally suited the black start function. The ability of hydropower units to quickly respond to these directives increases the value of hydropower resources to transmission operators and Reliability Coordinators. This feature was demonstrated in the 2003 Northeast blackout, when the flexibility of hydropower facilities and their ability to operate over a wide range of conditions allowed power to be restored and other types of generation to be brought back on-line [223].

Hydropower facilities also have enhanced abilities to quickly change operating points (i.e., respond to frequency disturbances and load following). These capabilities enhance contributions to the stability and reliability of the grid. While other generation sources can also perform these functions, the robust designs and simple mechanical systems of hydropower units mean they are minimally impacted by such changes and, as such, able to respond more quickly than fossil fuel generation units.

Hydropower units can operate reliably, meet environmental goals, and provide a range of grid services over a wide range of outputs. Few other units can provide this combination of services without considerable risk of equipment damage, especially at a MW size that can provide power restoration.

### Maximizing Market Value and Performance

Hydropower units are often the lowest production cost generators in an electric power system [224], so they are dispatched to replace higher cost generation resources that would otherwise be used (e.g., combined cycle natural gas generation). One strategy for economic dispatch in combined hydropower and thermal generation systems demands all of the hydropower generation (and water) that is available for the relevant period, so as to maximize the avoided costs of thermal generation. This demand for hydropower generation must be balanced against the future value of water for hydropower generation and other uses. Thus, the future value of water rewards efficiency in existing hydropower generation and limits the amount of hydropower available for meeting peak loads on a short-term (daily or hourly) time scale.

Other economic dispatch models use hydropower to meet load variability so that thermal sources can operate at an optimal base load setting. In this case, the value of water is balanced against the market demands and variable costs, including environmental costs, of operating thermal plants at less than optimal outputs (i.e., inefficient load points). Still another economic dispatch mode uses the flexibility of hydropower to follow the intermittent needs of the resource mix to meet variable load requirements and balance variable resource contributions. In order to maintain the reliability of the electrical bulk-power system, loads and resources must be balanced continuously and nearly instantaneously.

Operations of the river system—more than operations at the unit or project level—are the nexus of energy, water, and environmental policies. Ideally, those policies are sustainable and reflect the values of all stakeholders. Operational decision making for river systems typically reduces to hourly schedules of flow releases through each facility, which in turn controls reservoir elevations. In some cases, plants are used for inter-hour regulation of load/resources, which requires the same operational decision making. The tradeoffs that make decisions beneficial for one purpose and detrimental for another are often identified only by tracking the effects of releases and reservoir elevations though the multiple reservoirs that comprise a

71. NERC works with eight regional entities to improve the reliability of the electrical bulk-power system. The members of the regional entities come from all segments of the electric industry: investor-owned utilities; federal power agencies; rural electric cooperatives; state, municipal and provincial utilities; independent power producers; power marketers; and end-use customers. These entities account for virtually all the electricity supplied in the United States, Canada, and a portion of Baja California Norte, Mexico [222].

river system. Valuing multiple purposes and defining guidelines and policy for river system optimization and scheduling are issues that affect river system stakeholders and hydropower facility operators. Two examples of river system tradeoffs are:

- *The Columbia River Basin of the Pacific Northwest, where concern for resident and migrating fish species intertwine with needs for hydropower generation to support increasing penetration of wind and solar generation into multiple balancing authorities in the Pacific Northwest.* First, the releases of flows from the Columbia Basin headwater storage reservoirs provide salmon in the lower Snake and Columbia rivers with flows to enhance downstream migration. However, these releases may result in headwater reservoir water surface elevation variations that are not optimal for resident fish. Second, the optimal schedule of headwater reservoir flow releases to enhance either salmon migration or resident species habitat is not identical to the optimal schedule for hydropower generation at hydropower facilities downstream. By definition, less energy value is created when the optimal generation schedule is not followed. Third, increasing capacity for wind and solar generation in the region is making the flexibility of hydropower generation more valuable, but the need to avoid disrupting the timing of flows for salmon outmigration and to avoid excessive spill at Columbia River dams may limit such flexibility. Multiple study and research efforts are aimed at understanding the tradeoffs between aquatic environmental objectives and power system reliability and stability in systems with coordinated wind, solar, and hydropower assets.
- *The Tennessee River Basin, where keeping storage reservoirs full on the Clinch, Holston, and French Broad Rivers into mid-summer benefits recreational users, but also exacerbates water quality problems in those storage reservoirs and ponding reservoirs downstream on the main stem Tennessee River* [225]. Again, storage reservoir releases affect the overall value of system power production by altering the amount of water than can be released for hydropower. Maintaining water in headwater reservoirs through late summer also alters the system-wide storage available to reduce flood risks downstream in the Tennessee River Basin.

These examples are indicative of river systems in general because they include a mix of tributary storage projects and mainstem ponding projects. Run-of-river projects are often situated in the lower portions of river systems, but may also be found in upper portions due to historical development or unique environmental and regulatory issues. Wunderlich [226] states that river system optimization that accounts for linkages between projects is preferable to individual optimization of projects. Welt et al. [227] studied several river systems and concluded that the potential for economic gains from optimization increased with rising complexity of the hydropower system and electric power market. Labadie [228] points out that, “substantial technical challenges and rewards abide with integrated optimization of interconnected reservoir systems.”

When water control in a river system rests with multiple authorities, an explicit coordination agreement between the authorities can often provide greater value than independent operations. Public safety and reliable operation require at least a minimum level of coordination and communication among federal and non-federal authorities and multiple facility owners. However, there are institutional boundaries, regulations, authorities, and other administrative constraints that must be reconciled before operational coordination can yield increased efficiencies and value. Within water resources optimization, there are tradeoffs between the level of detail and time horizon that can be accommodated in prescriptive computational modeling. This results partly from limitations on computing power and data handling capabilities, but also because there is a limit to the amount of detail decision makers can consider beyond several seasons. As a result, decision support systems for water resources in general and hydropower in particular have been collections of generally interconnected models, differentiated by their time step and horizon. Typical scheduling activities within hydropower operations include the following:

- Long-term storage allocation: A storage allocation module prescribes optimal turbine release volumes and end-of-time-step reservoir elevations over a planning period of one to two years.
- Short-term dispatch optimization: A short-term dispatch module disaggregates weekly or monthly average flows and generation totals into daily or hourly dispatches for each project for the subsequent 24 hours to two weeks.

- Near-real-time optimization: A near-real-time module uses unit commitment and load allocation algorithms to disaggregate project discharge or generation dispatches from a short-term module into hourly unit operations.

Optimization notwithstanding, water management policy for individual projects constructed solely for power generation must be consistent with river system flood control policies established by state and federal agencies. While many constraints and decisions are considered, the primary decisions determined through optimization at the river system level are the daily and weekly releases and the elevations of the storage reservoirs.

Hydropower facility owners are challenged by regulatory authorities and customers to keep electric rates flat or lower than inflation. As a result, owners examine their operations to reduce O&M expenses, which are the primary driver for operators to control costs. Some examples of reductions hydropower facility owners may pursue include:

- Implementation of remote or automated unit operations that reduce labor costs and result in faster control and reduce the risk of human error, e.g., incorrectly synchronizing a generating unit to the transmission grid;<sup>72</sup>
- Using remote operations to eliminate non-productive travel time for employees driving between remotely located facilities to perform routine unit operations;
- Using remote operations to terminate the need for onsite operations employees and associated housing expenses for remotely located facilities;
- Transition from manual local control to remote automated operation of generating units, allowing for implementation of remote monitoring of critical monitoring and trending critical generator and turbine data;
- Identifying the optimal number of maintenance staff by evaluating the tasks required to keep the plant functioning and meet generation targets; and
- Use of computer maintenance management systems to prioritize work, optimize schedules, and make efficient use of plant staff.

## 2.6.2 Operations and Maintenance Implementation Strategies

The two key support functions of a hydropower facility are operations and maintenance. In executing these activities, hydropower facility owners aim to minimize risk so maximum generation can be achieved within operating constraints; to minimize forced outages; and to have hydropower available when called upon by the dispatch center.

### *Control Schema and Staffing*

In the early development of hydropower, plants were small in capacity and produced generation for local distribution; many hydropower facilities were redeveloped mills. Hydropower facilities consisted mainly of the generating unit and limited balance of plant equipment, and the generating unit was controlled locally by an operator.

As electrical demand grew, the generation required to meet this demand required new and larger capacity electrical plants. This included hydropower, though such facilities were typically built some distance from the loads that required the electrical energy. As hydropower capacity grew, so did control complexity.

Hydropower facility owners use a variety of staffing approaches depending on facility capacity, location, and functional requirements. Smaller facilities with limited generation most likely are controlled from a regional center, while those with larger capacity may be staffed with personnel. Control schemes can also involve a hybrid approach, with limited onsite personnel serving as a backup to remote control equipment. In the hybrid case, the onsite personnel will perform other tasks such as maintenance and inspections.

### *Facility Maintenance*

Hydropower facility maintenance programs are designed to reduce or eliminate unplanned equipment failures so the generating units can provide electricity generation and other ancillary services to the electrical grid as needed. This usually includes all routine and non-routine maintenance of the facility and equipment for water conveyance (e.g., spillway gates, water conduits, flumes), as well as maintenance of hydraulic equipment related to the turbine, the generator and associated equipment, switchgear, balance of plant, and the step-up transformer. Each facility owner establishes a maintenance strategy that provides the desired and most cost-effective balance

72. In this case, possible equipment damage from the human error would involve the generator breaker and generator stator windings.

of reliability, production costs, outage times, maintenance costs, and other strategic criterion.

The design features of equipment in early facilities (1880s to 1930s) were generally robust, the instrumentation was basic, and control systems relied on human action. Generating equipment in early facilities consisted of a turbine, shaft, and open frame air-cooled generator that were connected to the transmission grid through cables, a generator breaker, and a step-up transformer. Auxiliary equipment was limited to basics such as ventilation fans, lighting, and station drainage pumps. These facilities used corrective maintenance along with preventative strategy.

As industrial technology developed, many hydropower facility owners incorporated new equipment into the powerhouse during refurbishment or replacement projects. For example, the AC generator's excitation system was powered by a shaft-driven or separate DC generator, which in turn powered the main generator field. These rotating DC generators had carbon brushes, which required maintenance on a weekly basis. By contrast, the maintenance requirements of modern solid state exciters reduce maintenance to an annual check and are equipped with diagnostic equipment that identifies defects. Even with this change, brushes and slip rings are still required to transmit electrical current to the field poles. These brushes produce carbon dust as they wear, which must be collected and disposed of periodically. The sub-sections that follow describe several maintenance strategies used in modern hydropower facilities.

**Condition-Based Maintenance.** Condition-based maintenance consists of scheduling inspection and maintenance activities only if and when mechanical or operational conditions warrant, by periodically monitoring the machinery for excessive vibration, temperature and/or lubrication degradation, or by observing any other abnormal trends that occur over time [229]. Improved equipment reliability and availability can be achieved through a better understanding of evolving condition and fault mechanisms. Equipment manufacturers and third party suppliers continue to develop sensors that can detect changes in equipment performance and notify staff for needed maintenance.

As power and monitoring equipment are changing, so are maintenance strategies, due in part to decreasing funds, staff reductions, and high expectations of power availability. The development of monitoring and diagnostic technology supports implementation

of condition-based maintenance. These improvements can be observed in plant equipment used in off-line tests as well as in-service data collection instruments, and provided through equipment communication ports. These data can be stored and analyzed in standard desktop computers in the facility. The interpretation of these data, however, requires special training, and oversight by experienced personnel is important in order to track performance trends.

In hydropower facilities, on-line sensor and diagnostic technology such as proximity probes focus on the turbine and generator. These technologies are used by engineering and facility staff to monitor anomalies that may require corrective maintenance. A comprehensive system could include a large number of probes, flow meters, partial discharge analysis, and other instrumentation [230].

The systems used to collect and analyze data must be able to detect deviations in select measurements, along with trending of collected data over a period of time. The systems must also be able to accommodate minor and random variations. More significant changes are brought to the attention of facility staff or technical experts who can further analyze the data and take appropriate action, such as scheduling an inspection and possible maintenance.

**Time-Based Preventative Maintenance.** Time-based (preventative) maintenance uses inspections performed on a schedule based on calendar time or machine run time. Such inspections are intended to detect, preclude, or mitigate degradation of a component or system, with the goal of sustaining or extending useful life by controlling degradation to an acceptable level [229]. Time-based maintenance is the most common method used by hydropower owners to manage their facilities. The defined time period and number of operations or machine operating hours is often determined based on operating experience, manufacturer recommendations, or regulatory requirements. Unlike condition-based maintenance, time-based maintenance does not require any sensor technology or monitoring systems, but may require test equipment.

A number of maintenance activities at most hydropower facilities are classified as time-based maintenance. Some of these are performed during planned outages, during which facility owners can conduct inspections, repair and cleaning activities, and diagnostic tests. These outages can be planned on



an annual, biennial, or triennial basis, depending on the owner's assessment. During any equipment disassembly, facility owners work to mitigate inadvertent damage.

Some examples of time-based maintenance activities performed during planned unit outages are:

- **Waterways**—Major water conveyance systems and structures such as intake gates are inspected for integrity, leakage, and other structural elements during planned outages.
- **Turbines**—One major issue with turbines is damage to the runner surface due to cavitation erosion, abrasive erosion, and corrosion. If the damage is too severe, repairs are undertaken during the immediate planned outage; otherwise, repairs are incorporated into the next planned outage. Other turbine features examined during planned outages include the turbine-to-throat ring clearances, the wicket gates, the turbine guide bearing, head covers, wicket gate operating mechanisms, and monitoring systems.
- **Generators**—During planned outages, the generator stator and rotor are inspected for loose parts such as stator coils, slot wedges, field windings, or mechanical components. The high voltage stator windings, rotor field coils, and exciters receive diagnostic electrical tests which could reveal potential problems for continued reliable service. Generator bearings, bearing cooling systems, stator cooling systems, support brackets, stator sole plates, and other components are also inspected.
- **Generator Step-Up Transformers**—A number of maintenance tasks and diagnostic tests are completed on step-up transformers during planned outages. Prior to removal from service, the electrical connections are checked for overheating with an infrared device. The transformer bushings are also inspected for signs of cracks and chips, and for proper oil level. The electrical diagnostic tests include winding and core insulation resistance as well as power factor.

Time-based maintenance tasks during planned outages include other features of the hydropower facility, e.g., inspections of water control equipment such as spillway gates, Howell Bungler valves or similar equipment, cranes, raw water circulating pumps, safety equipment. Critical protection devices such as potential and current transformers, relays, and station batteries are tested and maintained on a periodic basis to comply with NERC Reliability Standards.

Many equipment manufacturers recommend time-based maintenance actions to extend the service life of their equipment, e.g., lubrication, filter change, and cleaning activities. While time-based maintenance offers advantages over other maintenance methods, it is not without limitations. For instance, the strategy cannot prevent catastrophic failures, but it can reduce their number [229].

**Corrective (Reactive) Maintenance.** Corrective maintenance, also known as reactive maintenance, is an approach that requires no preplanning actions; equipment operates until it ceases to function. It is commonly known as “run it till it breaks” [229].

The advantages of this approach are that it requires no monitoring systems or instruments, has no upfront expenses, and results in maintenance only when required. However, breakdowns or failures can occur at times of peak generation, and waiting until that happens can require increased labor expenses for outside staff to correct or replace the defective component so the system can be returned to operation. The failure can also result in the loss of electrical generation or the inability to release water from the reservoir, and the initial failure of one component can result in collateral damage to other equipment. Replacement components may not be stocked on-site at the hydropower facility, which would extend the downtime. Given these challenges, the intentional use of corrective maintenance in a hydropower facility is generally limited to components that are not mission-critical or that can be replaced within a few hours, including some balance of plant equipment such as small motors and bearings, electrical solenoids, etc. This approach could be used at the equipment's end of physical or economic life.

**Reliability-Centered Maintenance.** Reliability-centered maintenance is a combination of predictive/preventative maintenance techniques, in concert with root cause analysis [229]. Reliability-centered maintenance is a systematic approach to evaluate a facility's equipment and resources to best achieve the highest degree of facility reliability and cost-effectiveness [229]. The result of a successful reliability-centered maintenance program is maintenance strategies that can be implemented with regard to each of the facility assets in order to optimize asset values. These maintenance strategies are optimized so that the functionality of the plant is maintained using cost-effective maintenance techniques.

Reliability-centered maintenance involves gathering O&M data, performing analysis, and developing options for maintenance, and then using that information to prepare the maintenance tasks. Feedback is gathered following the first round of completed maintenance to see if the options were optimal and accurate, and adjustments are made as needed. This process is repeated on a periodic basis when potential improvements are identified. Facility owners have found success in using elements of the reliability-centered maintenance approach, working with available resources.

### **Planning, Benchmarking, and Performance Assessment**

Hydropower facility owners seek optimal use of water for hydropower while maintaining environmental quality, preventing flood risk, and providing adequate municipal water supply and recreational activities. Accomplishing this requires accurate planning and optimization of available water. Planners use projected rainfall/runoff forecasts to determine expected generation. For facilities located in northern climates, snow pack levels are used in the planning process. Since these forecasts are developed at least a year in advance, the planning process is dynamic and requires revision over time. The process incorporates planned unit outages that can be executed during periods of low water availability. Planning for load-serving and system supply incorporates planned outages and maintenance using availability calculations such as Equivalent Availability Factor, Equivalent Forced Outage Factor, and facility electrical capacity.

Benchmarking compares the performance of hydropower facilities that perform similar functions. Understanding these differences allows a hydropower facility operator to quantify improvement potential relative to the practices of best performers, prioritize operating practices by their impact on performance, and consider ways in which prioritized practices may be applied internally to improve performance. The following data are typically included in a benchmarking program to compare hydropower facility operations:

- Pedigree data (facility type, capacity, age, unit size, type, configuration). These data are used to define peer groups of similar stations for comparisons.
- Cost data for all functional areas required to run a hydropower facility, including :
  - Operations

- Maintenance (generating plant, waterways and dams, buildings and grounds)
- Support (on-site and headquarters locations)
- Public affairs and regulatory requirements
- Investment, differentiated by long-term (7–10 years) projects in order to make routine O&M more comparable)

Cost data are normalized on a comparable unit-of-output basis, such as \$/MW or \$/MWh. The selection of the appropriate metric is best determined by the primary cost drivers for the functional area. For example, if the number of generating units is a primary driver of operations cost, then it would be useful to benchmark operations cost in \$/unit.

- Performance data such as Generating Availability Data System data that are collected by NERC as required for 20-MW and larger units (smaller generating units do not have this requirement). Service-level measures are calculated to quantify how well the function is accomplishing its goals. In plant maintenance, for example, forced outage rate and availability factors are used as a measure of how well stations have been maintained. Several individual service-level measures may be combined to form a single composite index.
- Labor data, which are typically reported as the number of full-time equivalent employees, normalized on a comparable unit-of-output basis, similar to cost. These data are used to compare staffing levels in each functional area, as well as various components of labor cost such as wages, benefits, overtime, and the use of contractors.
- Safety data such as Recordable Injury and Lost Time Accident Rates, as defined by the Occupational Safety and Health Administration.

After the data are collected and the proper metrics are calculated, cost and performance data for a hydropower facility can be compared with the corresponding data for the facility's peer group (as defined by its pedigree data, e.g., size, type, age). The hydropower facility owner can determine whether the facility is above or below the peer group median (or some other desired metric). When reviewing benchmarking data, a holistic view is optimal; the relationship between measures is more important than superior performance for any particular measure in isolation.

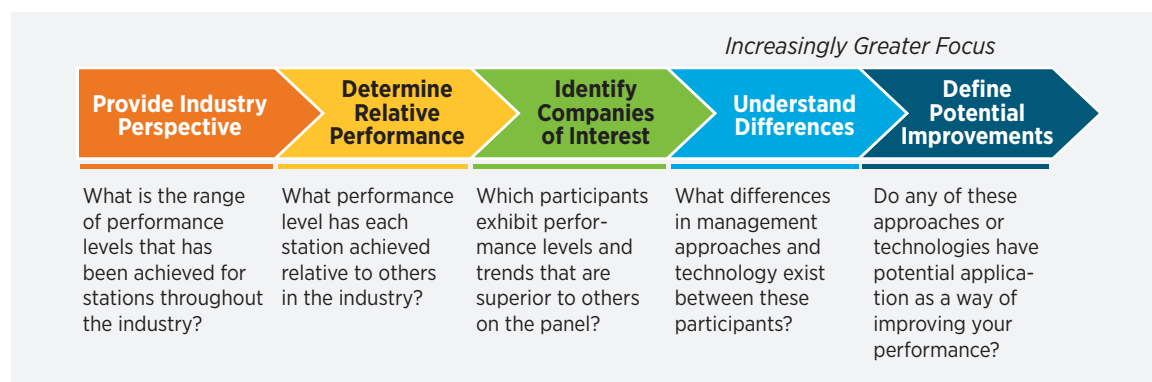

Source: Navigant Consulting

**Figure 2-40.** Flow of benchmarking information to guide performance improvement

Hydropower facility owners can use benchmarking data for multiple purposes, including reporting to facility and executive management, setting and justifying annual budgets, setting cost performance targets and tracking progress, and establishing formal performance improvement programs. There is typically a performance trade-off between unit cost and availability; for example, high availability can sometimes be achieved only with high unit costs.

Performance improvement programs recognize that benchmarking is the first phase of an overall generation improvement effort. The key is to identify innovative practices that are being used by the leading performers. Benchmarking information is used to identify the areas in which a more in-depth investigation is warranted—i.e., where performance is below benchmark—as well as the performers of different functions performed at a hydropower facility. Facility owners can conduct interviews of leading performers and use those results along with performance measures to identify how the leading companies achieve superior performance levels. The innovative practices identified for each function allow each participant to identify its improvement potential and target areas where the innovative practices may be applied. This process is summarized in Figure 2-40.

### **Upgrade and Refurbishment**

Hydropower facility owners implement equipment condition assessment programs to understand which components are near the end of their service life and, as such, to better project replacement needs and related expenses. This understanding can also be used to revise the maintenance program to extend the equipment's service life and improve unit

reliability. The condition of equipment can be determined through inspection by subject matter experts and enhanced with diagnostic instrumentation and periodic tests. Operating organizations use asset condition data to optimize expenditures by evaluating the opportunities and benefits for the greatest gain. These strategies seek to improve operational performance and prolong asset life.

Asset management is the systematic process of deploying, operating, maintaining, and upgrading assets cost effectively and in a prioritized way. It is also used to manage risk of equipment failure. In hydropower facilities, this is often also completed with limited resources. In the *Hydropower Vision*, "assets" are water control projects and components, including all equipment, structures, water conveyances, and reservoirs residing within the project boundaries. Assets also include the sensors and control systems that link physical projects to centralized dispatch facilities.

Hydropower asset managers contend with technical uncertainty and limited information, and they invest in research and collaborations within the hydropower industry to reduce technical uncertainty and to aggregate information for improved decision making. With an aging U.S. hydropower fleet and workforce, knowledge or inference about the condition of components is important to prioritizing limited funds for replacements, refurbishments, and upgrades, and to optimizing strategies for planned outages—within and among hydropower facilities. Facility owners use industry forums to share information on similar equipment and maintenance techniques, with the objective of extending service life and minimizing the risk of failure.

### 2.6.3 Trends and Opportunities

Trends and opportunities in Operations and Maintenance include:

- Development of best practices and justification for acquiring, validating, archiving, analyzing, and securing hydropower dispatch, cost, maintenance, condition monitoring, and performance data to maximize hydropower value.
- Movement of the industry and U.S. hydropower fleet to comprehensive benchmarking. It will be important to compile, disseminate, and implement best practices and benchmarking in operations and R&D.
- Understanding and creating parameters for the correlations and causalities among flexible hydropower dispatch, reliability, and O&M costs, and integrating such information into scheduling and planning processes.
- Development of best practices to include the effects of integrating environmental objectives into hydropower technology and operations decisions.
- Development of risk-based analytics to measure and manage dam safety, hydropower reliability, and hydropower scheduling.
- Assessment of benefits over a drainage area to determine the energy supply and market value impacts to environmental objectives and assess benefits over an entire drainage area (e.g., at the river system level) to achieve hydropower value while balancing regional environmental objectives (vs. just site specifics).
- Attraction of new workers into the hydropower industry along with the retention of the existing workforce. Training will be vital to the success of the industry in the future.

## 2.7 Pumped Storage Hydropower

The proven reliability, cost, and capacity potential of PSH demonstrate the technology's value as an energy storage resource for the United States. PSH functionality can be used to balance system loads and variable generation from other renewable resources on the grid. While existing PSH can provide operating flexibility, modern PSH technology represents an evolution from

existing PSH facilities, with new technology development and design parameters that support rapid response capabilities. These capabilities can support power systems with a large share of variable renewable generation technologies, such as wind and solar. As explained in this section, PSH provides a number of services and contributions to the power system, such

### Highlights:

- PSH is a proven, reliable, and commercially available large-scale energy storage resource. PSH provides 97% of total utility-scale electricity storage in the United States as of 2015 [2].
- As of 2015, the PSH plants in operation in the United States had a total installed capacity of about 22 GW. Many PSH plants were constructed to complement large baseload nuclear and coal power plants, where PSH increases loads at night and provides peaking power during the day.
- By helping to balance the grid, PSH plants reduce overall system generation costs and provide a number of ancillary services, including frequency regulation and voltage support, and help integrate variable renewable generation technologies into the grid.
- New advanced PSH technology, such as adjustable-speed units, provides additional capabilities beyond those of existing units.
- There is significant resource potential for new PSH development in the United States, but inherent market and regulatory challenges must be overcome to realize this potential.

as frequency regulation, contingency reserves, voltage support, and others. This section describes the significant resource potential that exists for the development of new PSH projects and the challenges that need to be overcome for this potential to be realized.

## 2.7.1 History and Status of Pumped Storage Hydropower

One of the earliest known applications of PSH technology was in Zurich, Switzerland, in 1882, where a pump and turbine operated with a small reservoir as a hydro-mechanical storage system for nearly a decade. The first unit in North America was the Rocky River PSH plant, constructed in 1929 on the Housatonic River in Connecticut. These early units were relatively basic; each had a motor and pump on one shaft and a separate shaft with a generator and turbine. The TVA constructed the first reversible pump/turbine (Hiwassee Unit 2) in North Carolina in 1956. At 59.5 MW, Hiwassee was larger than previous PSH installations. Developments in technology and materials have continued to improve overall efficiency and allow increasingly larger units to be constructed.

As of 2015, there were 40 PSH plants in operation in the United States, with a total installed capacity of about 22 GW [231]. Many of these plants were constructed from the 1960s through the 1980s to complement large baseload nuclear and coal power plants, where PSH increased loads at night and provided peaking power during the day. These units also served as backup capacity in the case of outages.

Because most PSH plants operating in the United States as of 2015 were built at least three decades ago, many do not take full advantage of modern advances in PSH technologies. For example, improved fixed-speed technologies have faster responses (mode change and load change times) and wider operating range (lower minimum load, wider operating head range), while adjustable-speed units also have the ability to provide regulation service in the pumping mode of operation. These innovations improve the capabilities of PSH to support grid

reliability and the integration of variable renewable generation resources, as discussed in more detail later in this section. While many proposed projects<sup>73</sup> in the United States are considering these more modern technologies, the innovations have been adopted more quickly by the rest of the world. For instance, more than 20 adjustable-speed PSH units have been placed into commercial operation since the 1990s—almost entirely in Japan and Europe—and several more are in design and construction phases [232].

Another PSH technology that provides flexibility is a ternary configuration with a hydraulic bypass. This type of ternary configuration has the motor/generator, turbine, and pump on the same shaft and rotating in the same direction, which allows for simultaneous operation of both the pump and turbine. Three 150-MW ternary units with hydraulic bypass have been installed at the Kops II plant in Austria, and several others are planned or in construction at other locations in Europe.

Worldwide, there are about 131 GW of PSH capacity in operation [233]. The regional distribution of global PSH capacity is presented in Table 2-6, while the locations and capacities of PSH facilities in the United States are illustrated in Figure 2-41.

**Table 2-6.** Global Pumped Storage Hydropower Capacity by Region

Region	Capacity (MW)
Asia and Oceania	55,786
Europe	50,015
North America	22,545
Eurasia	2,840
Africa	1,864
Central and South America	974
World	132,360

Source: EIA International Energy Statistics [233]

73. Adjustable-speed PSH technologies are being considered by developers of proposed PSH projects, including the 1,300-MW Eagle Mountain projects in California, and the 390-MW Swan Lake North project in Oregon.



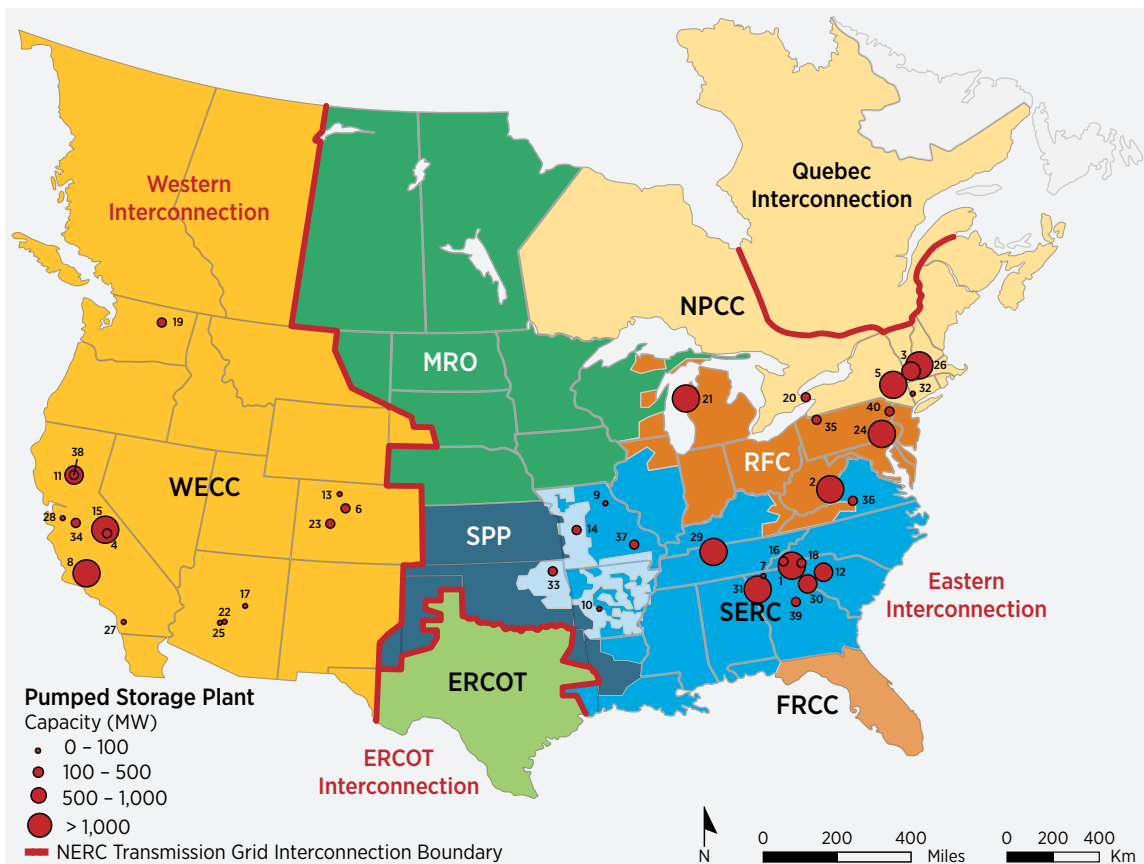

**NERC Regions**

ERCOT: Electric Reliability Council of Texas

FRCC: Florida Reliability Coordinating Council

MRO: Midwest Reliability Organization

NPCC: Northeast Power Coordinating Council

RFC: ReliabilityFirst Corporation

SERC: SERC Reliability Corporation

SPP: Southwest Power Pool

WECC: Western Electricity Coordinating Council

**Notes:** The Alaska Systems Coordinating Council (ASCC) is an Affiliate NERC member. Commercial electric power providers in Hawaii are not affiliated with NERC.

No.	Name	Capacity (MW)	No.	Name	Capacity (MW)
1.	Bad Creek Pumped Hydro Storage	1,065	22.	Mormon Flat Pumped Hydro Storage	50
2.	Bath County Pumped Storage Station	3,030	23.	Mount Elbert Power Plant	200
3.	Bear Swamp Hydroelectric Power Station	600	24.	Muddy Run Pumped Hydro Storage	1,070
4.	Big Creek (John S. Eastwood) Pumped Storage	199.8	25.	New Wadell Dam Pumped Hydro Storage	45
5.	Blenheim-Gilboa Pumped Storage Power Project	1,160	26.	Northfield Mountain Pumped Storage Hydroelectricity Facility	1,119
6.	Cabin Creek Generating Station	324	27.	Olivenhain-Hodges Storage Project	40
7.	Carters Dam Pumped Storage	250	28.	O'Neill Powerplant	25.2
8.	Castaic Pumped-Storage Plant	1,247	29.	Raccoon Mountain Pumped Storage	1,652
9.	Clarence Cannon Dam Pumped Storage	58	30.	Richard B. Russell Pumped Storage	600
10.	DeGray Lake Pumped Hydro Storage	28	31.	Rocky Mountain Hydroelectric Plant	1,095
11.	Edward Hyatt (Oroville) Power Plant	819	32.	Rocky River Pumped Storage Plant	29
12.	Fairfield Pumped Storage	511.2	33.	Salina Pumped Storage Project	260
13.	Flatiron Powerplant	8.5	34.	San Luis (William R. Gianelli) Pumped Storage Hydroelectric Powerplant	424
14.	Harry S. Truman Pumped Hydro Storage	161.4	35.	Seneca Pumped Storage Generation Station	440
15.	Helms Pumped Hydro Storage Project	1,212	36.	Smith Mountain Pumped Storage Project	247
16.	Hiwassee Dam	185	37.	Taum Sauk Hydroelectric Power Station	440
17.	Horse Mesa Pumped Hydro Storage	97	38.	Thermalito Pumping - Generating Plant	120
18.	Jocassee Pumped Hydro Storage	710	39.	Wallace Dam Pumped Storage	208
19.	John W. Keys III Pump-Generating Plant	314	40.	Yards Creek Pumped Storage	400
20.	Lewiston Pump-Generating Plant	240			
21.	Ludington Pumped Storage	1,872			

Source: Argonne National Laboratory

**Figure 2-41.** Existing pumped storage hydropower plants in the United States

## 2.7.2 Characteristics of Pumped Storage Hydropower Technologies

PSH plants can be designed in many different ways, depending on the geologic and hydrologic constraints of a given location. The typical configuration of a PSH plant is illustrated in Figure 2-42. It includes two reservoirs connected with waterways (water conductors), a powerhouse with hydropower machinery and equipment (pump/turbines, motor/generators, excitation systems, etc.), transmission switchyard (transformers) and a transmission connection. Most PSH plants use “reversible” pumps/turbines, which can switch from pumping to generation by reversing the rotation direction. Some plants, particularly those with high hydraulic head,<sup>74</sup> may require separate turbines and pumps. The two reservoirs should be located close to each other and have a significant elevation difference, which increases the potential energy of water stored in the upper reservoir.

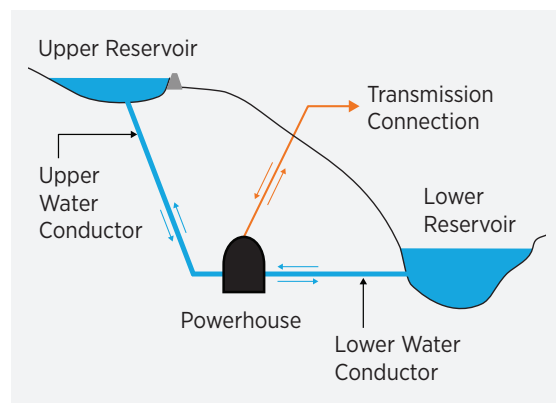

Source: Koritarov et al. 2014 [234]

**Figure 2-42.** Typical configuration of a pumped storage hydropower plant

Many PSH projects use reservoirs of existing hydropower facilities as their lower or upper reservoirs. Those PSH plants are typically referred to as “on-stream integral pumped storage” or “pump-back pumped storage.” The latter uses two reservoirs

located on the same river and can operate either as a typical hydropower plant, or, when the electricity demand is low, as a PSH facility.

PSH plants that are continuously connected to a naturally flowing water feature are called “open-loop” projects. Conversely, “closed-loop” PSH systems typically consist of two man-made reservoirs that are not continuously connected to such water features. One advantage of this off-stream approach is that these artificially created reservoirs could be made devoid of fish and other aquatic life, so the environmental impacts of PSH plant operation to river and lacustrine (lake) ecosystems could be reduced.

PSH reservoirs are sized based on the storage duty and operating cycle (day, week). In Europe, the trend is to add additional units to existing PSH plants.<sup>75</sup> This shortens the storage cycle time of the reservoir, but allows more energy to be cycled in shorter time frames.

Most existing PSH plants use traditional single-speed (or fixed-speed) technology, where both the pump/turbine and the motor/generator operate at a fixed synchronous speed. A major breakthrough in PSH technology was the introduction of the doubly-fed induction machine motor/generator with adjustable-speed capability.<sup>76</sup>

Adjustable-speed units provide a unique advantage in their ability to vary their power consumption during pumping, thereby providing frequency regulation in the pumping mode of operation [234]. Adjustable-speed units also operate with greater overall efficiency than fixed-speed units, especially when generating at partial load. This efficiency increase occurs because the rotating speed can be optimized for a given head and rate of water flow through the turbine. Depending on the design, adjustable-speed units may have a narrower rough zone<sup>77</sup> and the ability to generate at lower power levels—as low as 20%–30% of total installed capacity. These characteristics are illustrated in Figure 2-43.

74. For PSH plants, hydraulic head is the effective elevation difference between the upper and lower reservoirs.

75. For example, the new Kops II PSH facility in Austria, the planned 300-MW extension of Waldeck II in Germany, and PSH capacity additions at La Muela in Spain.

76. Unit 2 at Yagisawa PSH plant in Japan was the first adjustable-speed unit in operation. It was converted from fixed-speed to adjustable-speed by Toshiba in 1990.

77. Rough zones refer to operating ranges that need to be avoided due to excessive turbine vibrations and cavitation.

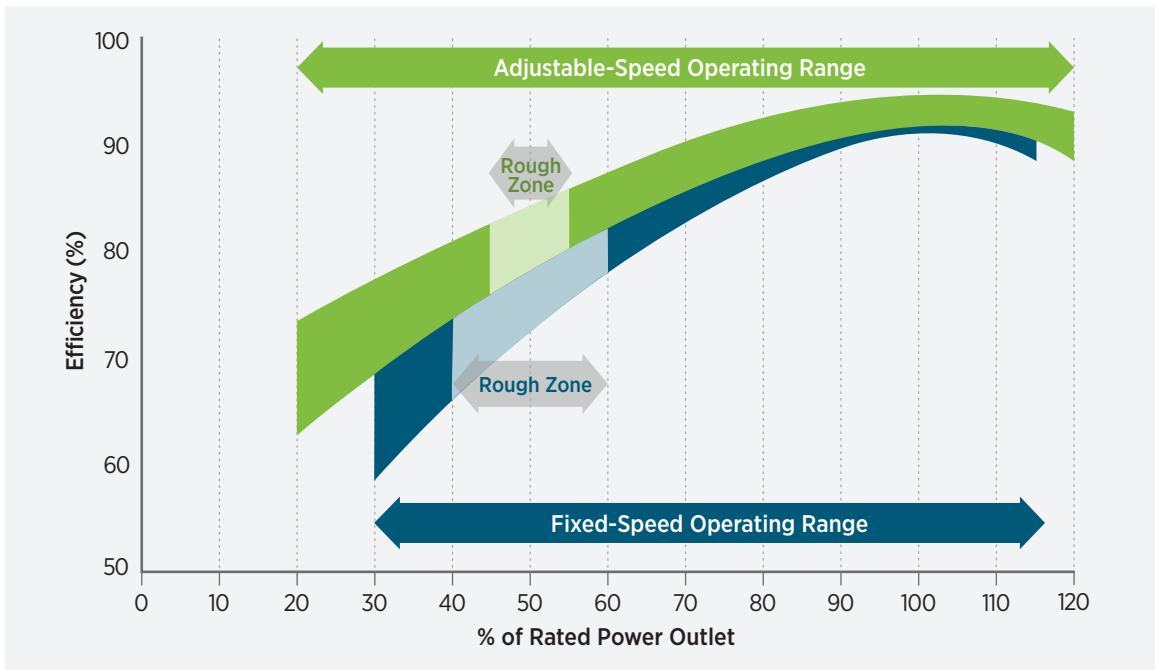

Source: Koritarov et al. 2014 [83], adapted from USACE 2009 [235]

**Figure 2-43.** Generation efficiency curves for fixed-speed (blue) and adjustable-speed (green) pumped storage hydropower units

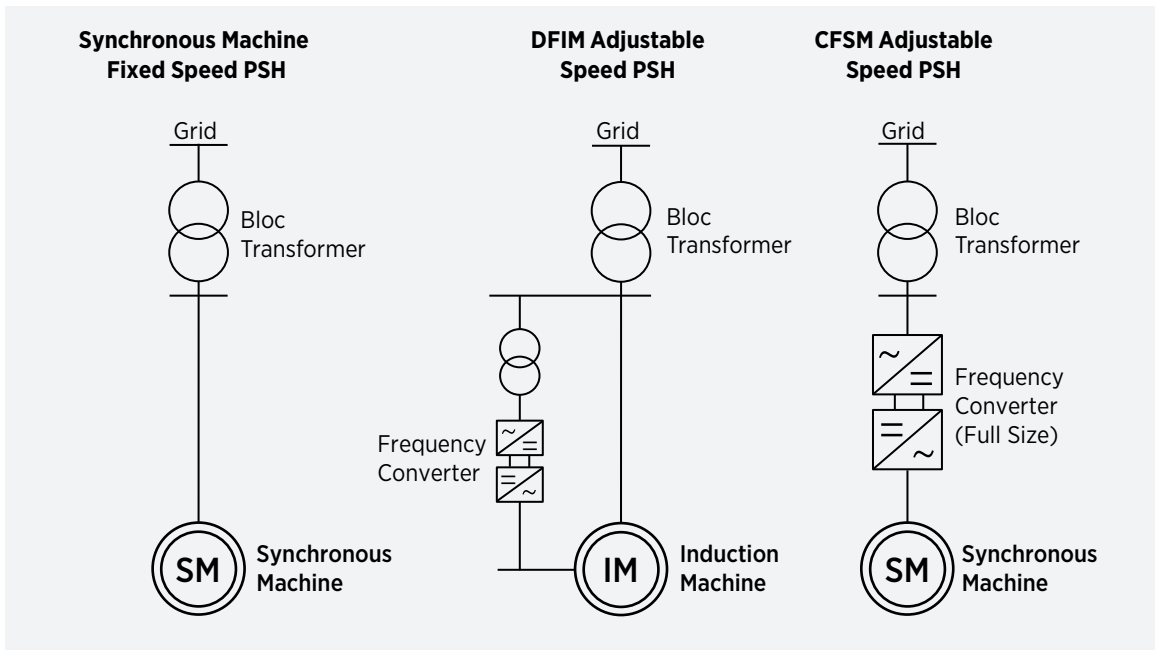

Note: DFIM = Doubly-Fed Induction Machine, CFSM = Converter-Fed Synchronous Machine.

Source: Koritarov et al. 2015

**Figure 2-44.** Electrical single line diagrams of fixed- and adjustable-speed pumped storage hydropower technologies

An additional benefit of advanced adjustable-speed technologies is the electronically decoupled control of active and reactive power, which provides more flexible voltage support for the system. Compared to fixed-speed PSH units, adjustable-speed PSH technologies may provide even better capability to support the stability of the power system in the case of sudden generator or transmission outages.

The adjustable-speed PSH technology was first developed in Japan in the 1990s, driven by the need for more flexibility in the country's nuclear-dependent power system. Since then, several adjustable-speed PSH plants have been built in Japan and Europe, and some existing fixed-speed PSH units have been converted to adjustable-speed technology.

The adjustable-speed operation of a PSH unit can also be achieved with a synchronous motor/generator if a full-size frequency converter is used to regulate the machine speed. This converter-fed synchronous machine technology was previously considered applicable only to smaller PSH units (less than 100 MW), but advances in converter technology may allow its applications to larger units [236]. Fixed- and adjustable-speed PSH units are diagrammed in Figure 2-44. In this figure, DFIM is doubly-fed induction machine and CFM is converter-fed synchronous machine.

A ternary PSH unit uses a separate turbine and pump on a single shaft with the motor/generator, and provides greater operational flexibility than fixed-speed PSH plants. Ternary plants with hydraulic bypass can simultaneously operate both the pump and turbine, as they are on the same shaft (connected with a clutch) and rotate in the same direction. Such simultaneous operation is also known as “hydraulic short circuit” or “mixed mode.” Ternary units can regulate the power that is supplied to the pump from the grid by varying the power output of the turbine. This allows them to operate across a wide range of power consumption levels, and to provide fast and significant regulation

up and down service as well (i.e., full unit capacity for regulation). Figure 2-45 illustrates the typical configuration of a ternary PSH plant with a hydraulic bypass [237]. A comparison of main technical and operating characteristics of key PSH technologies is provided in Table 2-7.

### Modular Pumped Storage Hydropower

As of 2015, most global and domestic PSH development had focused on the construction of large (typically several hundred MWs), site-customized plants. A number of smaller plants and units do exist, however. The viability of alternative design paradigms for PSH technologies has been actively discussed by the industry and in research (e.g., Hadjerioua et al. 2012 [239], 2014 [240]). No reliable determinations on the viability of these concepts have been made, however. The development of smaller, distributed PSH systems incorporating elements of modular design (i.e., using commercial off-the-shelf pumps, turbines, piping, tanks, and valves) may drive down investment cost, compensating the loss of economies of scale with cost reductions achieved through component standardization; reduce development risk; and increase the ease of implementation. Small modular PSH (m-PSH) could be a competitive option for small and distributed energy storage applications. In addition, m-PSH could avoid many of the major

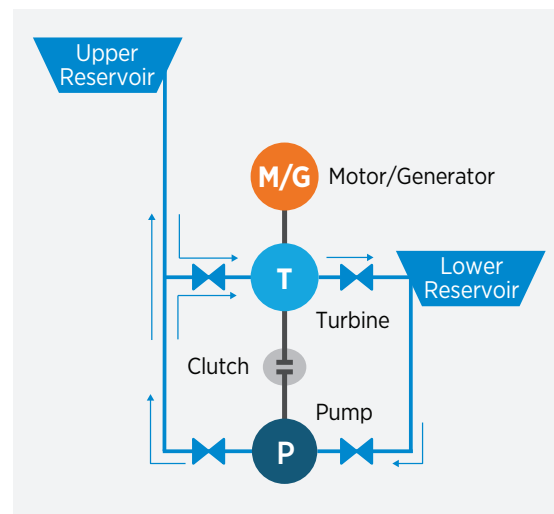

Source: Koritarov et al. 2013b [237]

**Figure 2-45.** Typical configuration of a ternary pumped storage hydropower with hydraulic bypass

**Table 2-7.** Typical Operating Characteristics of Key Pumped Storage Hydropower Technologies

Capability	Fixed-Speed PSH	DFIM Adjustable-Speed PSH	Ternary PSH with Hydraulic Bypass and Pelton Turbine
<b>Generation Mode:</b>			
Power output (% of rated capacity)	30% <sup>a</sup> -100%	20%-100%	0%-100%
Standstill to generating mode (seconds)	75-90	75-85	65
Generating to pumping mode (seconds)	240-420	240-415	25
Frequency regulation	Yes	Yes	Yes
Spinning reserve	Yes	Yes	Yes
Ramping/load following	Yes	Yes	Yes
Reactive power/voltage support	Yes	Yes	Yes
Generator dropping	Yes	Yes	Yes
<b>Pumping Mode:</b>			
Power consumption (% of rated capacity)	100%	60%-100% (75%-125%) <sup>b</sup>	0%-100%
Standstill to pumping mode (seconds)	160-340	160-230	80
Pumping to generating mode (seconds)	90-190	90-190	25
Frequency regulation	No	Yes	Yes
Spinning reserve	No	Yes	Yes
Ramping/load following	No	Yes	Yes
Reactive power/voltage support	Yes	Yes	Yes
Load shedding	Yes	Yes	Yes

a. One of the key factors determining the minimum power output is the hydraulic head. While fixed-speed PSH with high head can have the minimum as low as 20% of rated capacity, 40% is a more realistic value for medium to lower head PSH units.

b. If a PSH unit is converted from fixed- to adjustable-speed and the same pump-turbine runner is used, the power consumption may range from 75% to 125% of the former fixed-speed power consumption (100%).

Source: Koritarov et al. 2015 [238]



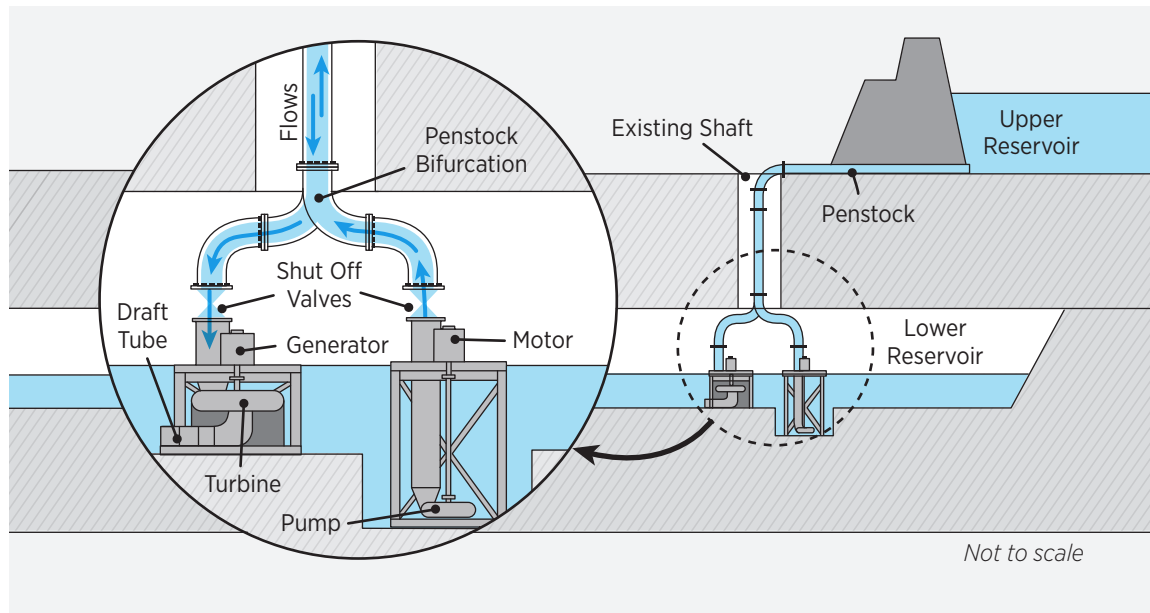

Source: Hadjerioua et al. 2014 [B3]

**Figure 2-46.** Pre-conceptual design of a potential modular pumped storage hydropower at existing coal mine

barriers commonly associated with large hydropower designs, including access to capital, a longer licensing process, and the potential impact to market prices (and subsequently revenues) caused by adding utility-scale storage to grid. Small m-PSH plants could potentially be developed at a variety of locations, including abandoned mines and quarries, many of them off-stream, thus avoiding a number of potential environmental issues. Figure 2-46 illustrates a potential m-PSH plant at an abandoned coal mine.

Ideally, m-PSH would be developed more rapidly, at lower risk, and with lower capital requirements than traditional large, site-customized plants. Some of the cost and design dynamics associated with this type of PSH development, however, are not well known, as the market for distributed energy storage has not developed. It is unclear, therefore, whether the benefits of modularization will be sufficient to outweigh the economies of scale inherent in utility-scale development, or if modular technology can be competitive with other alternative distributed storage technologies (i.e., batteries).

### **New PSH Concepts**

While PSH is one of the oldest energy technologies used for storing electric energy on a large scale, geological requirements for having two large water reservoirs at different elevations have often limited the locations where this storage technology can be applied. Many alternative PSH concepts are being explored to reduce or mitigate this challenge.

**Aquifer PSH.** Some aquifers can be used effectively as reservoirs in hydropower systems. Permeable aquifers have reservoir-like characteristics, and these can be exploited for hydropower generation. With aquifer PSH, water is pumped from the aquifer at off-peak times and stored above ground. When generation is needed, the water is allowed to fall back down to the aquifer to produce electricity. No large-scale aquifer storage project has been built as of 2015. Extensive research on the technology has been conducted, however, including a potential project at the Edwards Aquifer near San Antonio, Texas.

**Below-Ground Reservoir PSH.** Below-ground reservoirs such as old mine shafts, depleted natural gas formations, or tanks can be used as lower reservoirs for PSH. In such an application, water is pumped from the underground reservoir and stored above ground, then allowed to fall back down to the reservoir when generation is required. One such project is a potential 1,000-MW underground PSH facility in Granite Falls, Minnesota, for which a preliminary permit application was filed with FERC in 2010 by Riverbank Minnesota, LLC [241, 242].

**Energy Island PSH.** Several concepts for a pumped storage “energy island” (Figure 2-47) have been proposed for storing energy from wind turbines in Europe’s North Sea. These concepts generally include a ring dike encompassing an internal lake or lagoon that could be 100 feet or more below the surrounding sea level. During periods of excess available wind power, sea water would be pumped out of the island’s interior lake, generating a differential in elevation between the sea water outside and inside the dike.

When energy is needed during peak use periods or a lull in wind power production, sea water would be allowed to flow back in, generating electricity as in other types of pumped storage applications. Some concepts have incorporated turbines on the dike, and floating or fixed solar panels for additional electricity generation.

**In-Ground Storage Pipe PSH.** This hydraulic energy storage system consists of a storage shaft of 6–10 meters in diameter, housing a large piston built from pancakes of concrete and iron (Figure 2-48). Sliding seals surround the base of the piston. These seals allow the piston to move with minimal friction, and maintain the pressure differential above and below the mass. A return pipe of roughly two meters in diameter directs the water from the bottom of the shaft to the pump/turbine to generate electricity, or from the pump/turbine to the bottom of the shaft to raise the piston and store energy. Prototypical layouts allow for up to 2.4 GW per 2.5-acre footprint, with shafts extending 2,000 meters below the surface.

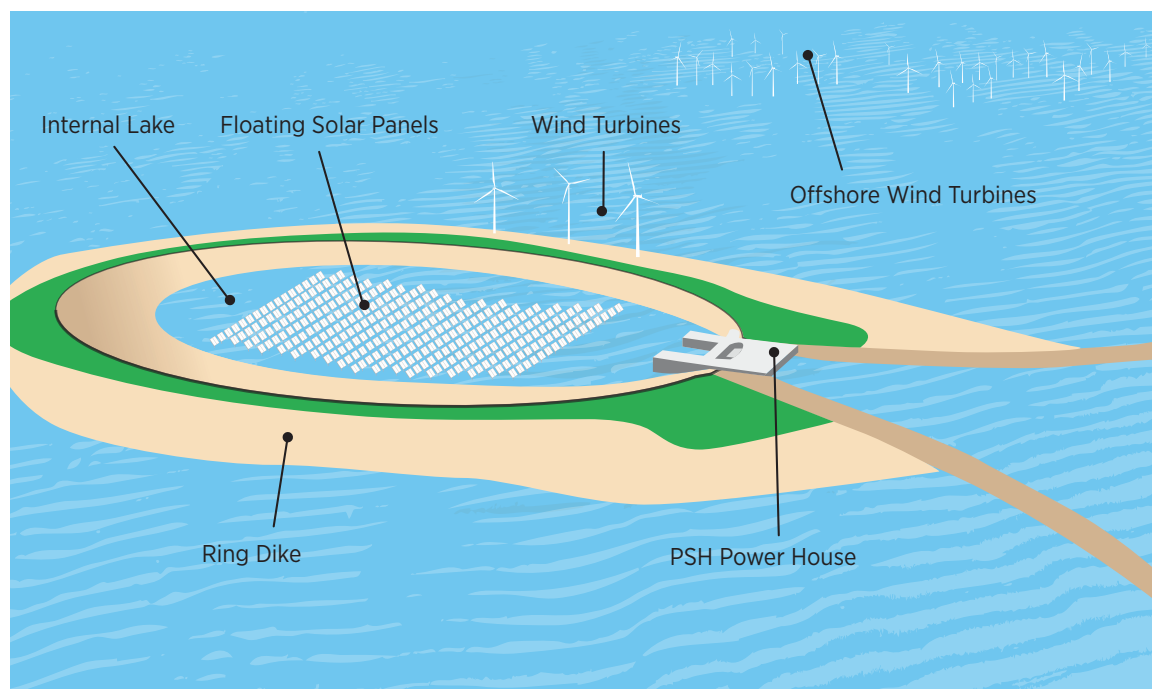

Source: National Renewable Energy Laboratory rendering, based on concepts proposed by the Belgian Ministry of Economy, Gottlieb Paludan Architects, and others

**Figure 2-47.** Energy Island pumped storage hydropower concept

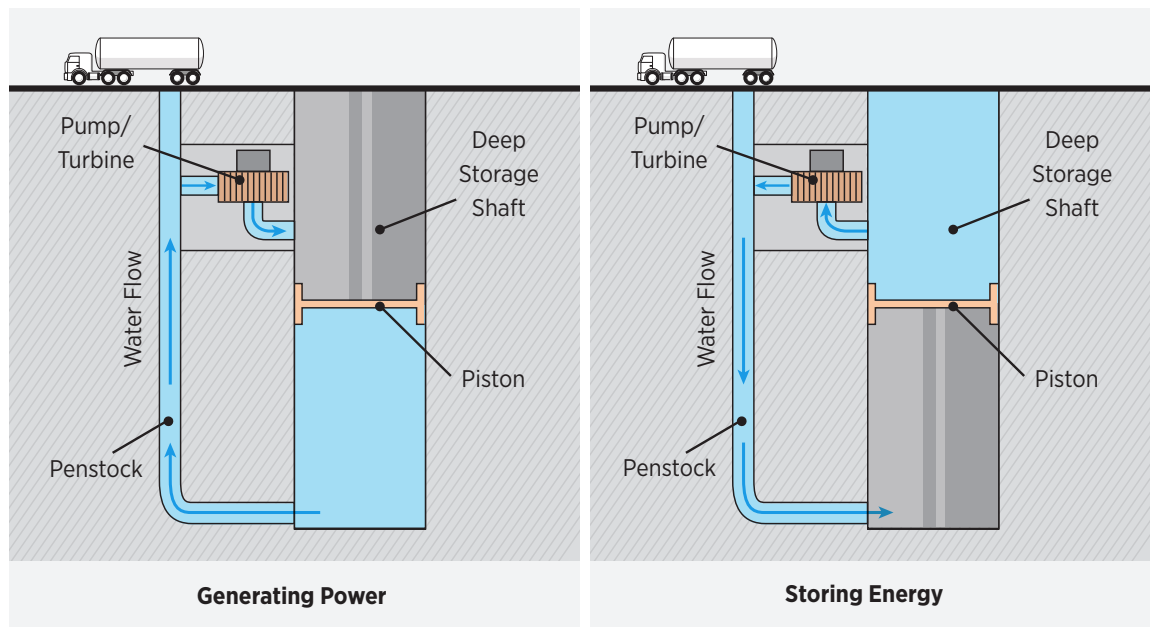

Source: Gravity Power [243]

**Figure 2-48.** In-ground pipe pumped storage hydropower concept

### *Comparison of Pumped Storage Hydropower to Other Energy Storage Technologies*

Growth in variable renewable generation has sparked renewed interest in energy storage technologies. As of 2015, research into the development of various grid-scale energy storage technologies, including batteries, flywheels, and compressed air energy storage was underway in the United States and internationally [244]. Figure 2-49 illustrates that PSH provides higher power ratings and larger energy storage capabilities than most other energy storage technologies. Compressed air energy storage is the only other technology that has facility generating capacity close to that for PSH. However, compressed air energy storage relies in part on fossil fuels for electricity generation (compressed air helps drive combustion turbines, thus reducing their use of natural gas fuel), and only a few compressed air energy storage plants are in operation. In contrast, PSH is a proven, commercially available, and reliable technology that compares favorably in terms of costs to most other energy storage solutions. As of 2013, PSH constituted 97% of the installed grid-scale energy storage capacity in the United States [2] and about 98% of the total energy storage capacity in the world [245].

### **2.7.3 The Role and Value of Pumped Storage Hydropower in Energy Systems**

PSH facilities are versatile and provide benefits to the power system. These facilities were historically built to perform load shifting from peak to off-peak periods and to serve as backup capacity in case of forced outages of large thermal and nuclear generating units. As the penetration of variable renewable generation technologies has increased, PSH facilities are increasingly used to help manage the variability and uncertainty associated with wind and solar power generation, and to provide other benefits to the power system. PSH facilities also enable greater integration of wind and solar resources into the system by reducing the curtailments of excess variable renewable generation [83].

It has also been shown that the value of PSH plants increases with higher penetration of variable renewable generation in the system [83]. PSH plants reduce overall system generation costs; provide flexibility and operating reserves; reduce cycling, ramping,

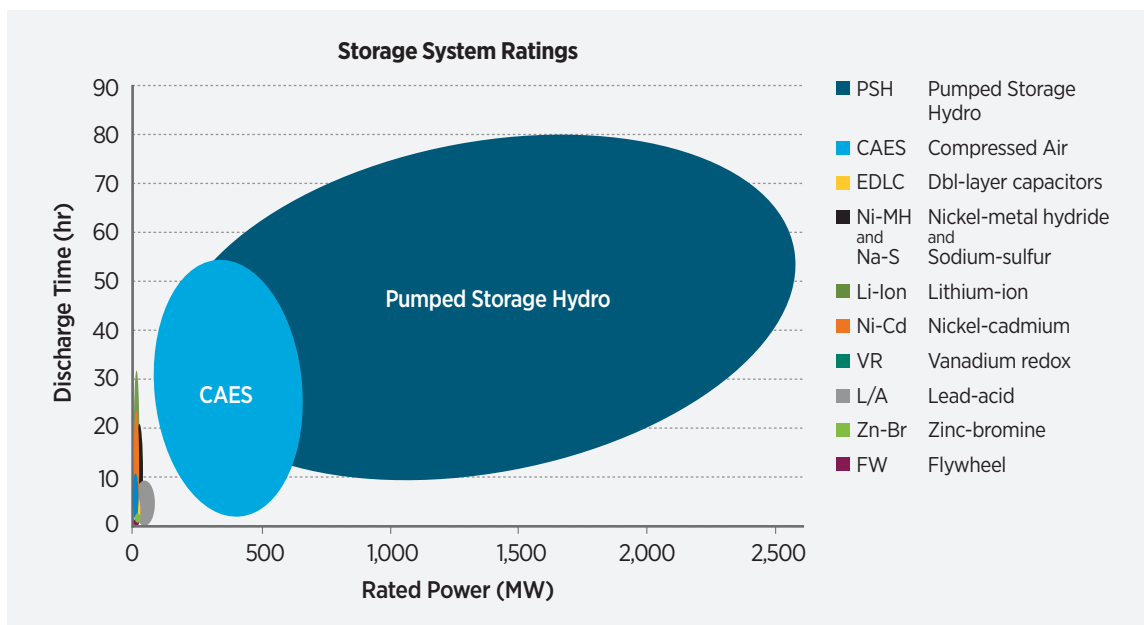

Source: HDR Inc.

**Figure 2-49.** Power rating vs. discharge time for energy storage technologies

and inefficient “part-load” operation of thermal generating units (Engels et al. 2010); reduce transmission congestion; increase the reliability of system operation; and provide other benefits [83]. Countries with a higher share of variable renewable generation, e.g., Germany, Austria, Spain, Portugal, are also the ones most active in constructing new PSH plants (Fisher et al 2012). A number of these new plants were designed to use advanced adjustable-speed and ternary technologies, as their additional flexibility in operation can compensate the fluctuations of variable renewable generation technologies. In addition, some existing PSH units, mostly in Japan, have been converted to adjustable-speed technology.

PSH technologies can contribute to operations and reliability requirements of the power grid [232, 83], including:

- Inertial response:** The rotating masses in fixed-speed and ternary PSH units can provide inertial response to the power system (i.e., provide ride-through power and keep generating units synchronized). Adjustable-speed PSH units can provide inertial response through the use of power converters by controlling machine rotation speed.
- Frequency regulation:** Adjustable-speed and ternary PSH can supply frequency regulation service in both pumping and generation modes, while fixed-speed PSH units can supply frequency regulation only when generating.
- Contingency reserves:** All PSH technologies can provide contingency reserves.
- Power system stability:** With respect to stability, fixed-speed and ternary PSH units have similar characteristics to other hydropower generators of the same size. The controls and capabilities of adjustable-speed units can be designed for improved performance under particular disturbances.
- Voltage support:** As with stability, fixed-speed and ternary PSH units have substantial voltage support capabilities comparable to those of other hydropower generators of the same size. Adjustable-speed PSH units can be designed to provide enhanced voltage support beyond the capabilities of other generators.

- **Load leveling / energy arbitrage:** PSH facilities can earn revenues by storing energy when electricity prices are low and generating when prices are high. This reduces the peak power demand by shifting load to off-peak periods.
- **Generating capacity:** Capacity contributions from PSH contribute to meeting peak demand in a power system. Specifically, the ability of PSH to switch quickly between pumping and generation means that a PSH facility can either consume power or generate power as required by demand on the power system.
- **Large integration of variable renewables:** PSH provides flexible, fast-ramping generating and pumping capacity, as well as various ancillary grid services. These services support integration of variable renewable generation technologies into the grid. PSH can also store surplus variable renewable generation, thereby reducing curtailments.
- **Cycling and ramping of thermal generating units:** The flexibility of PSH units allows thermal units to operate in a steadier mode by reducing the need for ramping and frequent startups and shutdowns. This reduces the operating costs and wear and tear of thermal units.
- **Transmission congestion:** The operational flexibility of PSH units can help reduce transmission congestion and improve utilization of transmission assets, thus reducing or deferring the need for investments in new transmission capacity. This is heavily dependent on the locations of PSH plants in the power system.
- **Black start capability:** In the case of a widespread blackout in the power grid, system restoration must begin from generating units with the ability to start independently. Fixed speed and ternary PSH units are good candidates to provide black start service. Adjustable-speed units may also provide this service if equipped with an external power source (e.g., diesel generator) to energize the power converter.
- **Power quality and reliability:** PSH units provide reserve capacity that can be quickly dispatched during generation or transmission outages, thus improving the reliability and resiliency of system operations.

## 2.7.4 PSH Resources/ Opportunities

Based on applications submitted to FERC, electric utilities and PSH developers are showing renewed interest in developing new PSH plants in the United States. This interest is triggered, in part, by the recognition that the rapid expansion of variable renewable generation technologies into the electric grid will require increasing power system flexibility.

### *Preliminary FERC Permits for New Pumped Storage Hydropower Projects*

FERC has seen an increase in the number of preliminary permit applications filed for PSH projects. A preliminary permit does not authorize construction, but it does maintain priority of the application for a license (i.e., guaranteed first-to-file status) while the developer studies the site and prepares to apply for a license. As of April 2016, there were 23 active, FERC-issued preliminary permits for proposed PSH projects, representing more than 18,000 MW of capacity. More than 70% of these preliminary permits are for locations in the Western Interconnection, where the majority of existing and proposed variable generation technologies are located. Figure 2-50 illustrates proposed PSH projects in the United States with preliminary permits issued by FERC; nearly half of the preliminary permits propose closed-loop design. Many proposed projects (e.g., Eagle Mountain, Swan Lake North)<sup>78</sup> are considering the use of adjustable-speed PSH technology, which can be applied in open- and closed-loop designs. The Eagle Mountain project passed the preliminary permit phase and was issued a license in 2014.

### *Upgrading Existing Pumped Storage Hydropower with Advanced Technology*

Interest has also grown in converting existing fixed-speed PSH facilities in the United States to use advanced adjustable-speed technology. Adjustable-speed PSH facilities can provide regulation service in pumping mode, which helps facilitate renewable integration.

78. Eagle Mountain is a 1,300-MW PSH closed-loop project in California, and Swan Lake North is a 390-MW PSH closed-loop project in Oregon.



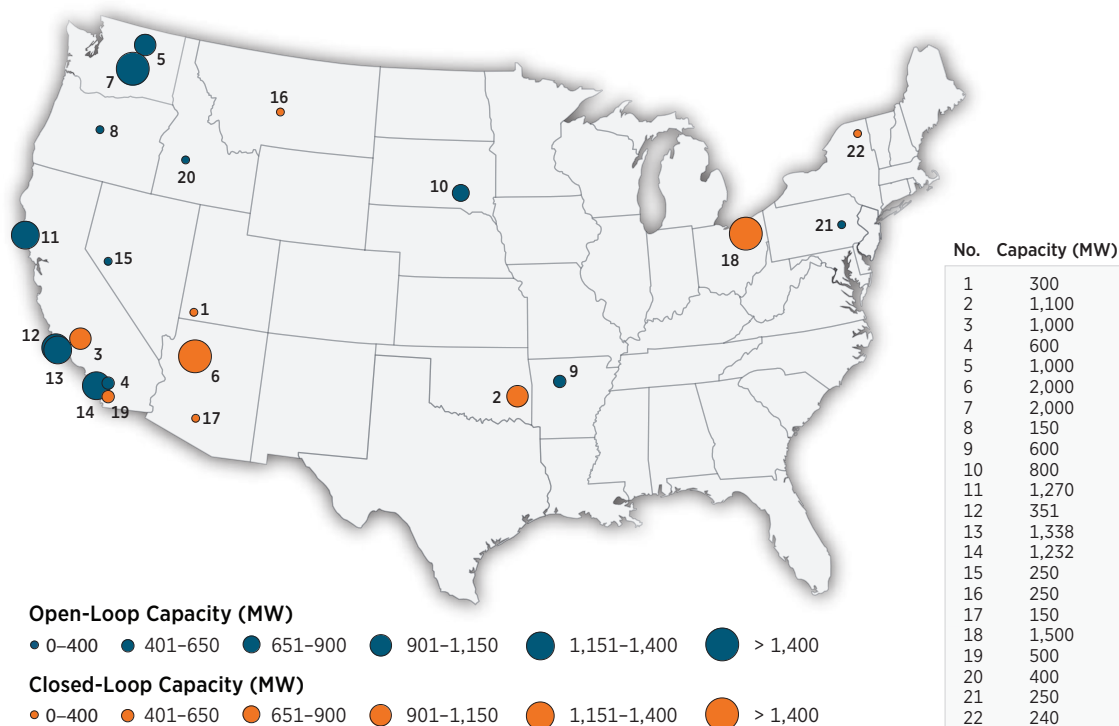

Note: Preliminary determination of open- vs. closed-loop classification based on preliminary permit application.

Source: FERC 2016 [246]

**Figure 2-50.** Preliminary permits for pumped storage hydropower in the United States

Not every fixed-speed PSH facility is a good candidate for conversion to adjustable-speed technology. A number of conditions related to civil structures and hydraulic, electrical, and mechanical systems need to be evaluated to determine if conversion is technically feasible and cost effective.

Internationally, several existing PSH plants have been converted to adjustable-speed technology. For example, in Japan, Unit 2 at the Yagisawa PSH plant was converted from fixed-speed to adjustable-speed in 1990. No conversions have been performed in the United States as of 2015.

## 2.7.5 New Pumped Storage Hydropower Development

New PSH can be developed by either the public or private sector. Most PSH facilities have been developed by electric utilities, both public and investor-owned. IPPs have shown interest in the development of new PSH facilities and have filed a number of applications for preliminary permits with FERC. IPPs hold more than 80% of the active preliminary permits for PSH projects, representing more than 15,000 MW of proposed capacity.

### **Pumped Storage Hydropower Development Process**

The PSH development process is similar regardless of the ownership types. This process involves the following considerations:

- **Determination of need.** Is there a need for the type of services that a PSH facility can provide? What are the projected types of services that will be needed in the long term, and what is the expected utilization of the PSH facility?
- **Market fundamentals.** The project business model must show that the PSH facility will be economically/financially viable given the regulatory and market environment. IPPs would want to know the conditions and/or requirements of long-term PPAs with a regulated utility before proceeding with development.
- **Site identification.** The characteristics of a potential site must be determined. These include:
  - *Technical aspects:*
    - The reservoirs, water conductors, and power plant must be designed to ensure that the resulting facility can perform as intended.
    - Developers must identify a water source for initial charge and make-up water for evaporative losses (closed-loop PSH), or identify an existing river or stream (open-loop PSH). An existing hydropower reservoir can also be used. The use of gray water from a waste treatment facility, storm water, sea water, and other non-potable sources are also possible options in some cases (typically for closed-loop PSH projects).
  - *Land ownership:*
    - Private lands: Projects may be sited on private lands in man-made or natural formations that could serve as lower or upper reservoirs, or use existing reservoirs/infrastructure. Abandoned coal surface mines and stone quarries are examples of man-made structures that could potentially be used as reservoirs for PSH projects.
    - Public lands: Projects may be sited within or adjacent to federal or state lands if they have features that are conducive to a PSH project.
- *Environmental aspects:* The project needs to comply with all relevant environmental laws and regulations.
- *Social and cultural aspects:* The project must comply with Section 106 of the National Historic Preservation Act and other similar laws and regulations at the relevant state and local levels of government.
- *Geotechnical analysis:* The developer must confirm that a project is feasible with regard to geotechnical risk.
- **Transmission interconnection.** The developer must determine options for interconnection with the transmission system. Specific issues include the length of the proposed tie-line and coordination with FERC’s jurisdictional interconnection process.
- **Permitting/licensing issues.** PSH projects require comprehensive environmental permitting at both the state and federal levels. If some or all of the land for the project is federally owned, additional time may be required for coordination among federal and state agencies. Potential impacts to recreational use, aquatic species, endangered species, and other issues require in-depth study similar to that for other types of hydropower.

### **Role of Pumped Storage Hydropower in Sustainable Energy Development**

PSH is a proven, reliable, commercially available technology that provides unique benefits (e.g., flexible capacity, energy storage, grid stability) for balancing variability of the load and variable renewable generation technologies, reducing their curtailments and increasing the overall reliability of power system operation. PSH can therefore help facilitate higher penetrations of variable renewable generation, which will result in an overall reduction in power sector emissions. PSH plants also improve the reliability and resilience of system operations by providing backup capacity that can be dispatched quickly during outages of large thermal units or other grid disturbances.

### **Environmental Impacts of Pumped Storage Hydropower**

Electricity generation by PSH facilities does not involve fossil fuels and thermal energy conversion processes. As with other storage technologies, PSH uses electricity from the grid to store energy. Net impacts on system emissions will depend on the generation mix that is used to provide energy for pumping at PSH units, and the generation mix that is displaced when PSH units are generating. In some systems, the net effect is positive, while in others it may be negative. Koritarov et al. [83] have shown that PSH impacts on emissions tend to decrease if more renewable energy is present in the system, as a larger share of pumping energy is provided by renewable generation and PSH plants also reduce curtailments of variable renewable generation technologies. In addition, PSH operation provides indirect emission benefits by allowing system operators to run fossil-fired plants more efficiently, with less ramping and unit cycling (start/stop operation).

In principle, PSH facilities are designed to have fast and flexible operating characteristics, so they are typically located at sites where the environmental impacts of such operation would be minimal. While open-loop PSH plants can have impacts on fish and other aquatic life, closed-loop PSH projects normally use two man-made reservoirs that are off-stream (not continuously connected to a naturally flowing water feature) and normally devoid of fish that could be affected by PSH operation. Typical PSH reservoir size is about one square mile, which is comparable to an average industrial site. Even closed-loop projects may have potential environmental issues, however, especially if they are constructed on brownfields (e.g., abandoned open pit mine lands) or other potentially contaminated areas. In addition, there are potential environmental impacts associated with activities that disturb the land during the reservoir construction process.

### **Regulatory Issues Influencing Pumped Storage Hydropower**

As with other hydropower projects, the licensing process for a new PSH project involves numerous activities and interactions with federal, state, municipal, and other authorities. There are also uncertainties

because PSH projects need to obtain multiple approvals. Any delays in licensing or approval processes may affect overall project development costs, sometimes significantly.

Closed-loop PSH projects could reduce some challenges for developers, because they eliminate effects on fisheries and reduce effects on other resources (e.g., water quality and visual resources) that exist under open-loop PSH. This in turn can expedite permitting processes. The Hydropower Regulatory Efficiency Act of 2013 directed FERC to investigate the feasibility of a 2-year licensing process for closed-loop PSH projects.

Although the duration of FERC's licensing process can be dependent on the details of the proposed project and the existing resources that would be affected by it, PSH developers can take certain actions to shorten the licensing process. Developers can design the project to minimize the alteration of existing water flow and its use, and locate the project where there is minimal potential to affect threatened or endangered species and on sites for which information on existing environmental resources and project effects is readily available. In addition, developers can begin coordination and consultation with agencies and stakeholders early in the planning process to resolve issues and begin collecting any additional information prior to beginning the licensing process.

### **2.7.6 Costs and Financing of Pumped Storage Hydropower**

Because of the site-specific nature of PSH project development, capital costs are difficult to broadly characterize and estimate. Costs of a PSH project are influenced by site-specific geotechnical and topological conditions; size of the reservoirs and dams or ring dikes; length of tunnels; use of surface vs. underground powerhouses; type of electromechanical technology; type of transmission system interconnection; environmental issues; the permitting process; the regulatory environment; the business plan; and the ownership structure. TB 2-11

Text Box 2-11.

### Pumped Storage Hydropower in Hawaii

The islanded nature of Hawaii's markets as well as the state's high energy costs and ambitious renewable energy goals (100% renewable generation by 2045) make it an ideal location for PSH to supply grid flexibility. PSH can work in tandem with other energy resources in the state (solar, wind) to function as a battery for these systems. The Kauai Island Utility Cooperative has proposed a 25-MW PSH facility for the Puu Lua reservoir on the west side of Kauai and is awaiting preliminary approval. Preliminary estimates put the cost of this project at between \$55 million and \$65 million. The utility estimates that the ultimate cost of electricity with the facility in place would be 35% less than the utility's traditional oil-based generation [249].

A study of historical costs for 14 representative PSH facilities in the United States estimated the cost of a fixed-speed PSH project to be between \$1,750/kW and \$2,500/kW [235]. Other assessments estimate capital costs for a new fixed-speed PSH project to be between \$1,850 and \$2,500/kW [248], between 1,500/kW and \$2,500/kW [250], and between \$1,000/kW and \$2,000/kW [251]. Estimates for the capital costs of a new adjustable-speed facility fall between \$1,800/kW and 3,200/kW [250].<sup>79</sup>

The design and construction of a PSH project represents a significant investment and requires detailed economic and financial modeling. Economic and financial models provide different ways of assessing the merits of a project in monetary terms; while an economic model evaluates the project from the perspective of society as a whole, the financial model (also known as business model or pro forma) evaluates

the project from the perspective of the owner. A developer will optimally conduct both economic and financial analyses.

The business model determines how project costs and benefits are allocated over time. Because PSH facilities can be developed by different types of owners, they will have different types of business models and distinct economic, competitive, and regulatory challenges. In the United States, utility-scale power plant ownership typically falls into two general categories: regulated utilities and IPPs.

#### Financing of PSH Projects by Regulated Utilities.

The financing of PSH projects by regulated utilities is a unique case. Regulated utilities typically use cost-based business models and recover the costs of reasonable capital investments through rates that are approved by state regulators. Because of this, regulated utilities are not exposed to market risk in the way that IPPs are, and the cost of equity is usually lower for utility projects than for IPP projects. As a result of lower cost of equity, the financial structure of utility projects tends to be more heavily weighted with equity. Also, utilities are often more receptive than IPPs to investments with long return periods.

In the IOU market sector, project financing is typically based on rate recovery or investor at-risk funding. Most IOUs choose the rate-based recovery approach to minimize financing risk, even for strategic projects which may serve a future grid need. For these rate-based projects, the return on investment is specified in the agreements with the state utility regulators (e.g., public utility commissions), thus documenting both the need for the project and the reduced risk to the investor shareholders. Such projects typically require pre-approval from the respective utility commission and, for large projects, the IOU normally prepares an initial application to study the project. The study proposal details the tasks and budget to take the project from initial concept to feasibility.

At the conclusion of the initial study, if the project is attractive from the perspective of both the IOU and electricity customers, a second application normally leads to more detailed design and construction phases. The initial proposal usually takes the IOU up to a year

79. The costs are listed as given in each study; they are not converted to present day dollars. Given the scale of various activities and long development times of PSH projects, there is always some uncertainty about what is included or excluded in reported capital costs. For example, it is often unknown whether the engineering, administration, financing fees, interest, or other "soft costs" are reported as project capital costs or if they are reported in some other way. Since these costs can be significant, any conclusions about project costs and guidelines that are based on historic data need to be considered with care.

to develop, and the utility commission usually requires another year or more to approve the initial studies. Subsequent design and construction periods normally extend three to five years, depending on the complexity of the design and the need for environmental studies. Even this financing approach is not completely without risk. The IOUs are normally required to provide a balance of debt and equity throughout this process and may be responsible for any cost overruns outside the rate recovery basis. Alternatively, the utility commission may require that the IOU share in any cost savings on the project when determining the final rate recovery basis.

**Financing of PSH Projects by IPPs.** IPPs use market-based business models and are fully exposed to the volatility of competitive electricity markets. This often leads them to favor low-risk projects because the return on project investment is not guaranteed. IPPs also tend to favor projects that are not capital-intensive and that have short construction time and quick returns.

Most IPPs will seek to finance projects with non-recourse project financing. This means that, for both equity and debt investors, the revenues and assets of the PSH project are the only source of principal and interest payments on debt and of returns on capital to equity investors. Given the regulated nature of electricity markets in the United States, project lenders are more likely to require IPPs to have long-term PPAs with creditworthy entities to provide additional security for repayment of project debt.

Lenders also want to have confidence that the combination of project revenues and project equity is sufficient for construction. Historically, many IPP projects—including wind, solar, and gas-fired combined cycle projects—were constructed under a lump sum, fixed price contract for engineering, procurement, and construction services, known as an “EPC Agreement.” Lenders have traditionally required the EPC Agreement Counterparty (usually at least one financially solvent construction company) to provide financial guarantees to support both the price and schedule provisions of the EPC Agreement. The use of such EPC Agreements is not typical for hydropower projects in the United States.

## 2.7.7 Treatment of Pumped Storage Hydropower in Electricity Markets

The value of PSH services and contributions to the grid depends on many factors, including their location in the system, the capacity mix of other generating technologies, the level of RE penetration within the system, the profile of electricity demand, the topology and available capacity of the transmission network, and other factors. Two PSH plants of similar size but in different locations may provide very different value to the power system. Hence, the valuation of PSH projects is site-specific and depends on the conditions within a particular utility system or electricity market.

While PSH plants provide numerous services and contributions to the power system (a total of 20 PSH services and contributions were identified by Koritarov et al. [83]), in existing U.S. electricity markets they typically can receive revenues only, from energy, certain ancillary services (typically for regulation, spinning, and non-spinning reserves), and capacity markets. The provision of black start capability is typically arranged through a long-term contract. Most existing markets have no established mechanisms to provide revenues for other services and contributions of PSH to the power grid. In contrast to competitive electricity markets, the traditional regulated utilities do not have established revenue streams for specific PSH services. The system operator typically optimizes the operation of PSH plants to minimize generation costs for the system as a whole. Therefore, in both traditional and restructured market environments, many PSH services and contributions are not explicitly monetized. Since PSH plants typically provide multiple services at the same time, it is difficult to distinguish the specific value of particular services and contributions, such as the inertial response, voltage support, transmission deferral, improved system reliability, and energy security.

### *Pumped Storage Hydropower Scheduling in Energy and Grid Services Markets*

Existing market rules related to scheduling resources in U.S. electricity markets are not favorable for PSH or other energy storage technologies. Electricity markets in the United States use a bidding process to



determine the market clearing levels of supply and demand offers for energy and ancillary grid services in the day-ahead and real-time markets. Most markets treat generation and demand functions of energy storage technologies separately and do not optimize their operation over the 24-hour period. While separate generation and demand bids work well for pure generation or demand market participants, this approach creates challenges for energy storage technologies such as pumped storage. These technologies both consume and produce electricity, and those two functions need to be coordinated.

In addition, the operation of PSH plants in sub-hourly markets is typically not fully optimized [252]. Ideally, the operation of a PSH plant should be optimized by a market operator (e.g., ISO/RTO). This would allow the ISO/RTO to make better use of the fast response characteristics of PSH plants, better balance the variability of load and variable generation resources, reduce overall power supply costs, and improve reliability of system operation. As shown in Table 2-7, PSH plants have extremely fast ramping capabilities and can quickly change their mode of operation, switching from pumping to generation, or vice versa, in minutes. Theoretically, if there is a need to provide fast ramping or balance the variability of load or of other renewables, a PSH facility could change mode of operation several times within the same hour.

PSH plants also participate in ancillary grid services markets, as they have technical capabilities to provide a number of ancillary service products in a cost-effective manner. Ideally, the energy and ancillary services provided by a PSH plant should be co-optimized to maximize the benefit for the entire power system.

The following topics related to market design issues could be studied to help system operators extract the full value of PSH [83].

- **Full optimization in day-ahead markets.** This optimization entails allowing the day-ahead market to schedule the mode of PSH based on minimizing costs over the full time horizon. As of 2015, PJM was the only market performing this type of optimization.
- **Full optimization in real-time markets.** This optimization entails allowing the real-time market to schedule the mode of PSH based on minimizing costs and information that has been updated since the day-ahead market. As of 2015, no market performed this action in the real-time unit commitment models.
- **Lost opportunity costs based on multiple hours for ancillary-service clearing prices.** Since the value of PSH depends greatly on its optimal operation over longer time periods (typically at least a day), the lost opportunity costs of its water resources are complex. Pricing mechanisms should account for situations where providing ancillary services in one hour results in a lost opportunity to provide energy in another.
- **Make-whole payments for PSH operation.** If PSH units are fully optimized in the market by the ISO, the owner/operators should be given guarantees by the ISO that following ISO schedules means operational losses will not be incurred [252].
- **Settlements based on sub-hourly time intervals.** If financial settlements are based on sub-hourly prices, the PSH plant will have opportunities to use its fast response to meet real-time pricing swings, since this would benefit both the plant and the power system. With settlements based on hourly prices, PSH and other resources have little incentive to respond to sub-hourly prices, and instead follow only the average hourly price. New York ISO, Southwest Power Pool, and CAISO settle sub-hourly, while all markets calculate sub-hourly prices as part of the real-time dispatch. FERC has proposed to require sub-hourly settlements in all markets.
- **Pay for performance for regulating reserves.** PSH can improve system reliability by providing regulating reserves that respond faster than those provided by many other technologies. PSH could therefore earn additional revenue if reserve payments were based on quality of performance (i.e., because PSH can provide similar services faster and with more reserve capacity compared to other technologies). All of the ISOs have modified rules in response to FERC Order 755 and are implementing design modifications related to a pay-for-performance market.

- **Market and pricing for primary frequency response.** Primary frequency response is a service that is not incentivized in most electricity markets. If the market for that service were established, it could provide an additional revenue stream for PSH, especially given that adjustable-speed PSH units are particularly well suited to provide primary frequency response. FERC has established a public docket to consider primary frequency response.
- **Market and pricing for flexibility reserves.** Different types of flexibility reserves are being proposed in the Mid-Continent and California ISOs, and are also discussed more broadly throughout the industry to address the operational challenges from variable renewable generation. Such new services can bring additional revenues to PSH plants, especially adjustable-speed PSH, which can provide reserves during both the generation and pumping modes of operation.
- **Market and pricing for voltage control.** As voltage support is a local service, there were no markets as of 2015 for voltage control in the United States, only cost recovery mechanisms. A pricing mechanism for voltage control could bring additional revenues to PSH.
- **Capital cost compensation.** Financing long-lived resources with high capital costs and low operating costs is difficult without a firm long-term commitment, regardless of how worthwhile a project is for rate payers. Capacity markets, where they exist, cover only a portion of capital costs for new units and only offer annual commitments at most. Treating PSH as a regulated, rate-based, transmission-like resource under system operator control might be beneficial by providing more certainty to PSH investors.
- Recognition of existing market rules and their impact on energy storage value, which could advance PSH. Energy storage acts as both generation and load, but in most markets those two functions are considered and procured separately. Storage value propositions include sub-hourly benefits that may not be captured with standard power system models and methods. In addition, storage value propositions span generation, transmission, and distribution systems and include a variety of benefits provided to the overall power system that are typically not part of revenue streams for energy storage projects.
- Improvement in understanding that, while many new energy storage technologies have had limited commercialization, this is not the case with PSH, a commercially proven and available technology.
- Standardization of the communications and control systems of new energy storage technologies, which could help PSH interoperate with existing utility systems.
- Advancements to streamlining the licensing process for PSH projects in order to expedite development.
- Sub-hourly settlements in energy markets and increased opportunities for energy arbitrage in sub-hourly markets.
- Treatment of PSH as a new storage asset class, which could help capture the full value of services and improve the economics in areas with resource constraints. In addition, crediting hydropower and PSH for its fast regulation response could improve system operations in situations where resource adequacy is a power system reliability issue.

Key recommendations from a recent DOE Report to Congress [66], for activities that can help accelerate pumped storage developments in the United States include the development of tools that would help evaluate the feasibility of conversion from fixed-speed to adjustable-speed technologies, and investigation of market mechanisms that would accurately compensate PSH for the full range of services provided to the power grid.

## 2.7.8 Trends and Opportunities

Trends and opportunities for PSH and for new energy storage in general include:

- Development of next-generation PSH technologies, and validation of the performance and reliability of these new technologies to contribute to hydro-power growth.
- Enhancement of the environmental performance of new and existing PSH technologies. For example, environmental issues associated with PSH siting may be reduced with closed-loop PSH.

## 2.8 Economic Impact of Hydropower

Hydropower makes economic contributions in many regions of the United States. The construction and operation of hydropower facilities requires a qualified workforce and stimulates economic activity related to those jobs. To describe the role that hydropower plays in the U.S. economy through employment, this section categorizes and quantifies the number of workers employed; provides estimates of workforce demographics, which are key to planning for future hydropower; and discusses how most hydropower facilities also have non-hydropower uses (e.g., recreation and flood management) that have economic value in their own right.

### Highlights:

- In 2013, operations, construction, and upgrades at conventional hydropower plants supported approximately 143,000 jobs in the United States.
- Nearly 25,000 jobs are supported nationally by hydropower construction and upgrades, along with \$1.4 billion in earnings (\$2004), and nearly \$3.3 billion in output.
- Multiple uses of existing hydropower facilities, such as recreation, transportation, drinking water, and flood management, can provide net economic benefits.

### 2.8.1 Hydropower Employment and Related Economic Activity

Hydropower owners need workers to operate and maintain facilities, install upgrades, and permit and construct new facilities. Construction and operation have an economic ripple effect—companies further down the supply chain need production workers, transportation workers, accountants,

lawyers, managers, and other types of workers to supply inputs such as generation equipment, business-to-business services, or other materials. Workers supported by these expenditures—those who work at hydropower sites as well as throughout the supply chain—spend money on housing, transportation, recreation, food, health care, and other economic goods. These impacts, known as induced effects, are also quantified in this section. The total number of jobs and their ripple effect provide insight into how hydropower supports employment and economic activity in the United States.

This section contains impacts estimated using a combination of observed employment and economic modeling. Navigant Consulting, Inc., maintains GKS Hydro<sup>®</sup>, a database of observed employment at hydropower facilities in North America that serves as the source for data about onsite O&M jobs. DOE's Jobs and Economic Development Impacts (JEDI) [253] Conventional Hydro model is used to estimate all other O&M and construction phase jobs, as well as workers' earnings and overall output.<sup>80</sup> JEDI is an input-output (I-O) model that can be used to estimate gross economic impacts for energy projects. Appendix H contains more detail about the JEDI methodology, including general information about the model and how to interpret results.

As of year-end 2013, hydropower O&M supports approximately 118,000 total ongoing full-time equivalent (FTE) jobs nationwide (Table 2-8). Navigant Consulting, Inc. estimates that more than 23,000 of these jobs are at operating sites, with such jobs as plant operators, mechanics, electricians, and engineers [254].<sup>81</sup> These positions earn an average of \$50,000–\$56,000 annually (Table 2-8). The JEDI model presents results in three categories: Project Development and On-site Labor; Local Revenue, Turbine, and Supply Chain; and Induced. Figure 2-51 illustrates the economic ripple effect from one hydropower facility and includes sample jobs in each result category.

80. JEDI reports employment in full-time equivalent (FTE) jobs. One FTE is the equivalent of one person working 40 hours per week for one year. Earnings include wages and salaries, as well as employer provided supplements such as health insurance and retirement contributions. Output is a measure of overall economic activity. It includes all payments for inputs and the value of production.

81. Navigant also produced estimates of hydropower jobs in 2009. These estimates are not directly comparable to those presented here, however, because the *Hydropower Vision* solely includes construction and O&M activity associated with conventional hydropower, whereas Navigant included a more broad set of technologies in its previous study. Further differences between the Navigant studies can be explained by temporary spikes in hydropower activity around 2008 and 2009.

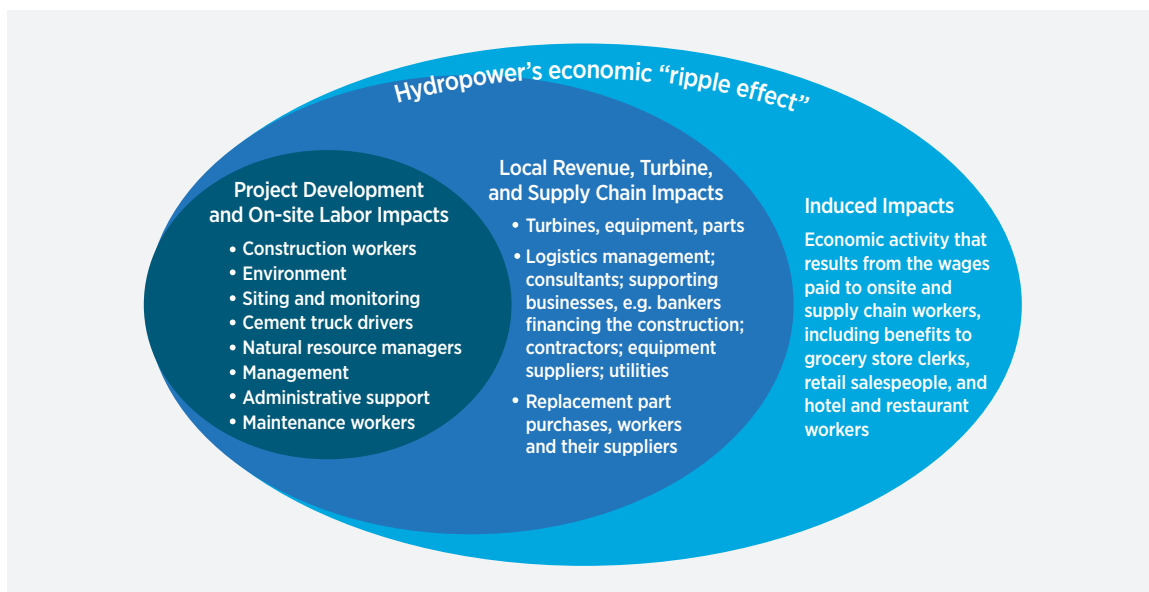

Source: National Renewable Energy Laboratory

**Figure 2-51.** Hydropower's economic ripple effect: sample occupations by category from the Jobs and Economic Development Impacts mode

**Table 2-8.** Estimate of Employment, Earnings, and Output from the Operation of Hydropower Facilities (2013)

	Employment (FTE)	Earnings (Millions, \$2004)	Average Annual FTE Earnings (\$2004)	Output (Millions, \$2004)
<b>Onsite</b>	23,000	\$1,300	\$56,000	\$1,300
<b>Supply Chain</b>	54,000	\$2,800	\$52,000	\$10,400
<b>Induced</b>	41,000	\$1,800	\$50,000	\$5,400
<b>Total</b>	118,000	\$5,900	\$53,000	\$17,100

Sources: Navigant [254] (for onsite employment data only); remainder of data from JEDI

JEDI modeling calculates that, in 2013, supply chain and industry expenditures from hydropower O&M supported an estimated 54,000 jobs and nearly \$10.4 billion in output (Table 2-9). Similar to onsite jobs, these positions earn an average over \$50,000 annually, for a total of more than \$2.8 billion in earnings. This category includes jobs in areas such as steel production, concrete factory workers, consultants, and accountants. Expenditures made by onsite and supply chain workers support an estimated 41,000

induced jobs, \$5.4 billion in economic activity, and \$1.8 billion in earnings. This translates to average annual compensation of \$50,000.

Table 2-8 lists 2013 domestic jobs in each of the JEDI result categories, along with the associated earnings and overall economic activity. The on-site employment data are from consulting and research firm Navigant [255], while the other data are results from JEDI modeling.



Source: Daniel Rabon

**Figure 2-52.** Final adjustments of line boring equipment for installation of new turbine blade dowels

**Table 2-9.** Estimate of Economic Activity Supported by Construction and Upgrades at Hydropower Facilities

	Employment (FTE)	Earnings (Millions, \$2004)	Output (Millions, \$2004)
<b>Onsite</b>	8,000	\$600	\$900
<b>Supply Chain</b>	6,000	\$400	\$1,100
<b>Induced</b>	11,000	\$500	\$1,400
<b>Total</b>	25,000	\$1,400	\$3,300

Note: Totals may not sum due to rounding

Source: Navigant [254]

Construction and upgrades also support employment (Figure 2-52), although it is inherently temporary and lasts only as long as the upgrade or installation does. This is not to say that these jobs do not exist prior to and after projects, however; they could have been supported by hydropower or other construction activity in the past and could continue to be supported by other activities in the future, although this possibility is not estimated in the *Hydropower Vision*. Navigant [256] identified nearly 90 expansion and upgrade projects in the United States in 2013, along with several small (less than 1 MW) new construction projects.

Construction and upgrades to existing facilities are a smaller portion of economic activity than operation of existing facilities, but still a measurable part of the overall hydropower workforce.

Nearly 25,000 jobs are supported nationally by hydropower construction and upgrades, along with \$1.4 billion in earnings (\$2004), and nearly \$3.3 billion in output (Table 2-9). The majority of these—approximately 10,500—are induced jobs that are supported by onsite and supply chain worker expenditures. Estimates show nearly 8,000 onsite workers and more than 6,000 through the supply chain.



## 2.8.2 Hydropower Workforce Demographics and Occupations

Hydropower has existed in the United States long enough to create a multi-generation workforce, i.e., one that has seen the retirements of workers who entered the industry as young professionals. Estimating the ages and occupations of hydropower workers provides insight and helps the industry understand potential future staffing needs. This is particularly important for occupations that require high levels of education or hydropower-specific training and that also have high concentrations of older workers who are nearing retirement age. Such positions may be difficult to fill due to education requirements and competition for workers from industries with similar workforce needs, and that difficulty would be compounded by the need to fill many of them within a short time span. The demographics of the hydropower workforce can be used to estimate future worker replacement needs and communicate these needs to institutions that provide education and training, as well as to individuals who might pursue careers in the hydropower

industry.<sup>82</sup> Table 2-10 includes the distribution of onsite hydropower workers by occupation categories, with sample jobs listed for each.<sup>83</sup>

As illustrated in Figure 2-53, certain hydropower occupations may face high concentrations of workers retiring by 2030.<sup>84</sup> Managerial, supervisory, and highly skilled craft worker occupations are older than the U.S. average, with a concentration between the ages of 46 and 55. This is not always the case—there are more engineers and unskilled craft workers between age 26 and 35 than the U.S. average. Hydropower workers in other professional occupations most closely resemble the United States as a whole.<sup>85</sup>

High concentrations of older workers could indicate difficulty replacing the workforce, but it does not necessarily confirm this. For instance, the age distribution in managerial and supervisory occupations that is older than the distribution for all U.S. workers could represent movement from non-supervisory or management occupations after gaining experience in the hydropower industry [254]. Yet skilled craft workers

**Table 2-10.** Distribution of 2013 Onsite Hydropower Operations and Maintenance Workers by Occupation

Occupation Category	Sample Jobs	Employment (2013)
Craft workers, unskilled	Construction laborers, helpers	1,500
Craft workers, skilled	Heavy equipment operators, mechanics	6,200
Supervisory craft workers	Managers of electricians, mechanics	1,500
Managers	Program managers, operations managers	1,100
Engineering	Civil engineers, environmental engineers	2,800
Administration	Accountants, clerical workers	3,000
Professional	Biologists, hydrologists, regulatory/compliance support workers	7,100

Source: Navigant [254]

82. Chapter 3 of the *Hydropower Vision* includes projections of replacement needs by occupational category through 2050.

83. Appendix I contains further detail about specific occupations included in each category.

84. The *Hydropower Vision Roadmap* contains further detail about workforce projections.

85. All distribution lines show a slight increase in the oldest age category. This is because the oldest category includes all workers of ages 65 and older, whereas all other age groups only include workers of one age.

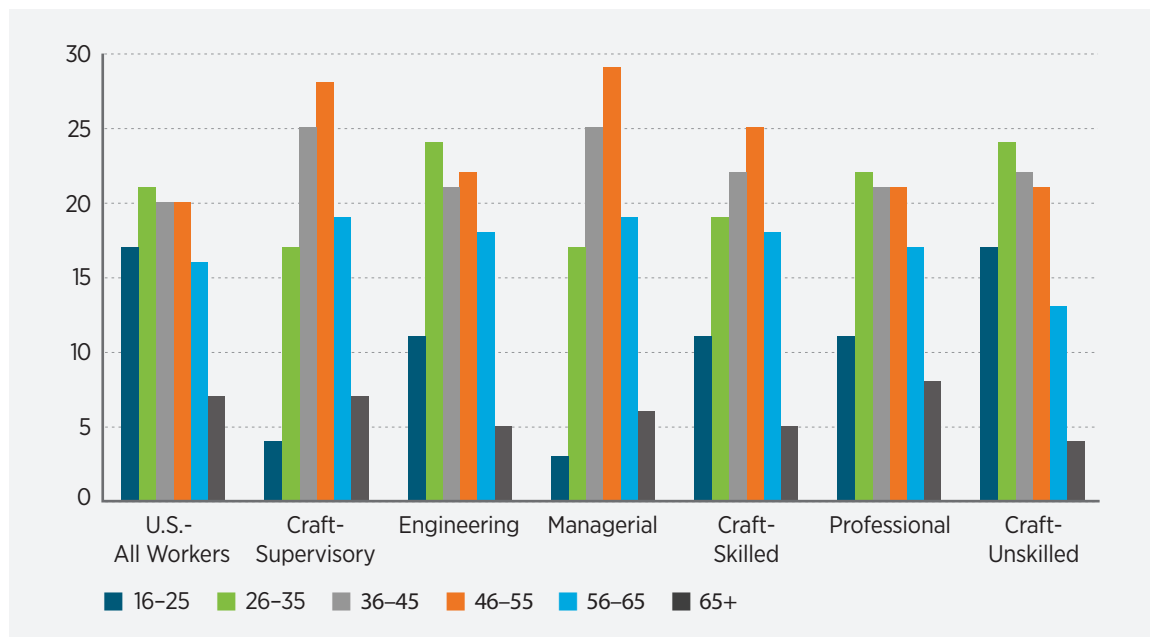

Sources: U.S. Census Bureau American Community Survey [257], Navigant [256]

**Figure 2-53.** Age distributions of workers in hydropower occupations and distribution of all U.S. workers (2013)

are also older than average, so advancing skilled craft workers to supervisory positions as supervisors retire may prove problematic, as the pool of skilled craft workers who could fill these positions are themselves near retirement age. Filling managerial occupations may be somewhat less problematic, as these could draw from the pool of engineers and workers in professional occupations. Chapter 3 of the *Hydropower Vision* report provides a more detailed discussion of future workforce needs, including estimates of retirements by occupation.

### **Regional Distribution of Onsite Workers by Occupation**

Another key factor to consider when evaluating the hydropower workforce is location of the worker. The number of workers varies regionally, as do the number and size of hydropower facilities; hydropower facilities are concentrated in the Pacific and Southeast. The widest regional differences can be seen in skilled craft workers and professionals; the range of skilled craft workers as a percentage of total regional hydropower employment ranges from 39% in the Northeast to 18% in the Southeast (Table 2-11). Similarly, professionals account for 41% of the onsite O&M workforce in the Southeast and only 16% of the workforce in the Rockies [254].

Regional differences in workforce are due to a number of factors. Different regions have different geographies and resources, and hydropower is more common in some areas than others. Staffing requirements at large facilities differ from those at small facilities, so the mix of small and large hydropower plants also impacts the distribution of workers. Further variation can be explained by O&M practices that differ by company, technology, and region. For example, some companies have a central staffing pool that serves several dams, while other companies have staff onsite at most of their dams.

Potential workforce replacement needs, therefore, could vary regionally. For example, skilled craft workers are older on average than the U.S. average workforce, and generally older than most other occupations within the hydropower workforce. Replacement of these workers may be less complicated in the Southeast, which has a lower concentration of workers within these occupations than the Northeast. This is further explored in chapter 3 of the *Hydropower Vision* report, which contains projections of workforce replacement needs as well as estimates of new hydropower workers that could be needed to fulfill the *Hydropower Vision*.

Text Box 2-12.

### Economic Development Driven by Inexpensive Electricity

Hydropower can support economic development activity by providing a relatively inexpensive source of electricity, compared to other generation sources. Businesses—especially those that consume large amounts of electricity—can recognize advantages to locate in areas with hydropower to minimize their costs. The New York Power Authority requires businesses that receive hydropower to provide employment data so that the Authority can track the number of jobs created or retained due to lower-priced electricity. The New York Power Authority estimates that approximately 800 New York businesses and non-profits receive hydropower and support approximately 426,000 jobs [258].

Data show job creation due to hydropower in other regions as well. Microsoft, Yahoo, and Dell, for example, built large data centers in the Pacific Northwest because of inexpensive, clean hydropower [259]. Similarly, Apple purchased the DOE-funded 45-mile Hydroelectric Project from Earth By Design Hydro to power data centers in Central Oregon. Energy-intensive companies such as aluminum manufacturers have historically chosen to locate in areas with hydropower (and, in turn, inexpensive and reliable electricity), such as upstate New York and the Pacific Northwest [260].

**Table 2-11.** Percentage of Workers within Each Occupational Category by Region

	Northeast	Southeast	Southwest	Midwest	Rockies	Pacific
<b>Craft—Unskilled</b>	5%	4%	5%	10%	14%	7%
<b>Craft—Skilled</b>	39%	18%	28%	34%	35%	28%
<b>Craft—Supervisory</b>	6%	7%	8%	5%	9%	5%
<b>Managerial</b>	6%	5%	3%	5%	8%	3%
<b>Engineering</b>	14%	11%	11%	12%	6%	14%
<b>Administrative Clerical</b>	12%	14%	10%	10%	13%	14%
<b>Professional</b>	18%	41%	38%	24%	16%	29%

Source: Navigant [254]

### 2.8.3 Economic Impacts from Multiple Uses

Hydropower construction and O&M activity do not fully capture the economic impact of hydropower. It is unique among electricity generation sources in that many facilities in existence have multiple uses such as recreation, transportation, water supply, flood control, and others. A hydropower facility's economic value often exceeds that of electricity generation and has an impact on local economies and jobs. This necessitates a broad approach and the inclusion of such uses when assessing the economic effects of hydropower.

Despite the importance of estimating national impacts from multiple uses, the calculations are not always straightforward. Multi-purpose reservoirs, for example, often serve competing uses for a variety of stakeholders, such as water storage for irrigation and recreational activities like boating. Furthermore, hydropower uses can vary from site to site because of geography, regional needs, the size of facilities, and other factors. Government agencies, consultancies, academics, and professionals have sought to quantify both positive and negative impacts from hydropower facilities in

cost-benefit studies, but these analyses typically focus on a specific site or region. Summaries of several of these studies are presented in Table 2-12 to provide insight into the range of national hydropower benefits beyond those from electricity generation.

Results from the studies cited in Table 2-12 vary from site to site depending on the scope of the facility and the method of assessment; however, all show positive net economic benefits from hydropower, even when considering impacts such as loss of potential revenue from fishing or boating. The methodologies also vary depending on scope, although within the United States most follow guidelines and evaluation techniques established by federal agencies such as the Corps, the U.S. Water Resources Council, the FERC, Reclamation, and the Department of the Interior.

Studies conducted by these federal agencies suggest considerable overall economic impacts from the multiple uses of hydropower facilities, often in excess of benefits from electricity generation, construction, or O&M. This is compounded by the fact that many hydropower facilities, especially large reservoirs, have been in existence for many years and benefits have accrued over time.

**Table 2-12.** Summary of Study Results Quantifying Impacts from Multiple Uses of Hydropower

Study	Project and Geography	Uses Analyzed	Estimated Impact
Reclamation [261] and Reclamation [262]	Hoover Dam Nevada, Arizona	Irrigation, flood control	\$2.6 billion since 1950
McMahon et al. [263]	Reallocated water use at Lake Lanier and the Apalachicola-Chattahoochee-Flint River Basin	Recreation, water supply, includes loss of benefits	\$20 billion over 57 years
Corps [264]	Garrison Dam Lake Sakakaewa, North Dakota	Flood control, navigation, water supply, recreation, hydroelectricity	\$1.8 billion lifetime benefits
Corps, cited in Oak Ridge National Laboratory [265]	Varies	Flood control	\$20 billion annually
Department of the Interior [267]	Western United States	Irrigation, domestic water supply	\$60 billion in economic activity; 378,000 annual jobs

For example, Reclamation [261] estimates \$1.26 billion in direct flood control benefits from the Hoover Dam since 1950 and Reclamation [262] estimates a total crop value of approximately \$1.34 billion from the dam's irrigation water system in 1991 alone. The Hoover Dam provides water supply to more than 20 million people [261]. The Corps [264] reached similar conclusions when estimating economic impacts from the Garrison Dam/Lake Sakakaewa project in North Dakota, estimating total lifetime<sup>86</sup> benefits from the dam of approximately \$1.8 billion, with \$415 million from flood control, \$7 million from navigation, \$606 million from water supply, \$86 million from recreation, and \$639 million from hydropower use, respectively.

McMahon et al. [263] analyzed competing uses for Lake Lanier and the Apalachicola-Chattahoochee-Flint River Basin, the principal source of drinking and industrial water supply for the Atlanta metropolitan area, and found that the value of multiple uses exceeds the value of electricity from the hydropower. Lake Lanier serves a range of purposes, including hydropower, navigation, and recreation. Under the Apalachicola-Chattahoochee-Flint Basin Water Control Plan, priority has been given to hydropower and navigation objectives in reservoir management. McMahon et al. [263] compared alternative water allocations for municipal and industrial water supply, hydropower, and recreation. The present value of total benefits from reallocated water use has been estimated to increase from \$19,100 million to \$19,253 million during the 57 years of remaining lifetime of the basin [263]. Individual benefits for recreational purposes have been calculated to increase from \$808 million to \$982 million, and by \$19,100 million for municipal and industrial water supply. Benefits from reducing hydropower generation to accommodate additional recreation and water supply have been estimated to decrease from \$74 million to \$53 million [263].<sup>87</sup>

The finding of significant positive net economic impacts from the multiple uses of dams and hydropower projects is repeated in other surveys of studies. A 2015 report by the Oak Ridge National Laboratory [265], for example, highlighted some of these findings. Oak Ridge cited a Corps estimate that flood control from multi-purpose hydropower facilities alone

prevented more than \$20 billion in flood damages annually, making flood control one of the most economically beneficial benefits from reservoirs [268]. An appraisal from the Department of the Interior suggested that irrigation water from Reclamation reservoirs generated \$55.2 billion in economic output and supported 353,000 jobs nationwide (DOI, 2014). Benefits of a smaller magnitude have been estimated for municipal and industrial water supply benefits, estimated to support 25,000 jobs annually and \$4.7 billion in economic output in the West in 2013 alone [267]. Oak Ridge also referenced benefits of cooling water for the electricity sector to have a value of \$14 (\$2014) per acre-foot [269].

### *Analysis of Competing Uses*

Multiple uses of dams and hydropower facilities can also lead to competing uses. Population change, drought, changing regional preferences, or many other factors could lead to an evaluation of the economic impact of reducing different uses of hydropower facilities, including generation of electricity. Because many of these factors, such as population preferences and geography, can be variable, it is difficult to make a general statement about what use of reservoirs or hydropower facilities is optimal. Despite this variability and subsequent ambiguity, these competing (or potentially competing) uses are part of the economic value of hydropower. Researchers have attempted to quantify optimal uses of specific sites and come to different conclusions for different dams and facilities. Table 2-13 provides a summary of these studies.

Loomis [270] estimated potential recreation benefits from dam removal and subsequent restoration of the Lower Snake River in Washington. The analysis estimated 1.5 million visitor days five years after the removal of the four dams on Lower Snake River, and 2.5 million visitors annually during years 20-100, resulting in annualized benefits of \$193 million to \$310 million. The study concludes that these benefits exceeded the reservoir recreation loss of \$31.6 million, but were about \$60 million less than the total cost of the dam removal alternative. This study looked solely at recreation and tourism, not electricity from hydropower, but still provides insight into different types of recreation in a specific region.

86. Modelled for an 80-year period of analysis.

87. This example is anecdotal, not a quantitative estimate of losses.



**Table 2-13.** Studies that Quantify Impacts of Competing Dams and Hydropower Facility Uses

Study	Project and Geography	Competing Uses	Results
Loomis [270]	Lower Snake River Washington	Reservoir and river recreation	River recreation benefits exceed reservoir benefits by \$161 to \$278 million
Debnath et al. [271]	Lake Tenkiller Oklahoma	Electricity and Recreation	Recreation benefits exceed electricity benefits
Ward and Lynch [272]	Rio Chama basin New Mexico	Electricity and Recreation	Electricity benefits exceed recreation losses from managing lake volumes

Debnath et al. [271] conducted a study on hydropower in Oklahoma, evaluating hydropower generation and urban and rural water supply versus recreational uses at Lake Tenkiller. The findings suggested that the value of electricity that could be generated by releasing more water and lowering the lake level below its normal level in the summer months was more than offset by reduced recreational benefits. Similar results were obtained by Hanson et al. [273], who found that during summer, when recreational benefits were valued most, higher lake levels should be maintained.

In contrast, Ward and Lynch [272] also looked at trade-offs between managing lake levels for recreation and hydropower in New Mexico. They found that benefits of hydropower electric production were higher than losses from managing lake volumes for recreation.<sup>88</sup>

## 2.8.4 Trends and Opportunities

The main trend and opportunity for Economic Value of Hydropower is that of replacing the existing hydropower workforce over time, as workers retire. These replacements will be needed in addition to new jobs supported by construction and operation of any new facilities. Therefore, development and promotion of professional and trade-level training and education programs is critical.

Hydropower is an economic driver in some regions of the country, supporting economic activity from construction and O&M as well as providing inexpensive electricity to help businesses compete globally. The multiple uses of hydropower facilities also have substantial economic impacts. Studies reviewed in this section focus on existing dams and larger hydropower installations, which aren't necessarily the same types of installations that will be built in the future. However, these new facilities will still have impacts beyond their construction and operation years. Hydropower can displace more carbon-intensive forms of generation, reducing GHG emissions and improving public health. These impacts are quantified and monetized in Chapter 3 of the *Hydropower Vision* report.

Chapter 3 explores these potential future impacts that could arise as a result of achieving the *Hydropower Vision*. It contains estimates of the economic value of GHG reductions, public health impacts from reduced pollution, reduced water consumption, and job needs supported by the *Hydropower Vision*. It also contains projections of when existing hydropower workers will retire or otherwise exit the hydropower workforce, providing estimates of the number of workers needed simply to maintain current employment levels.

<sup>88</sup> Ward and Lynch [272] do not address specific aspects of recreation benefits such as boating or real estate values. These were estimated with the New Mexico Fish and Wildlife Department's RIOFISH model.

## Chapter 2 References

---

- [1] U.S. Energy Information Administration (2015c). Table 7.2b Electricity Net Generation: Electric Power Sector. Monthly Energy Review. October 27, 2015. Accessed May 24, 2016. <http://www.eia.gov/totalenergy/data/monthly/>.
- [2] Uria-Martinez, R.; P. O'Connor; and M. Johnson. 2015. 2014 Hydropower Market Report. DOE/EE 1195. U.S. Department of Energy, Washington, D.C. (US). Accessed May 2, 2016, <http://energy.gov/eere/water/downloads/2014-hydropower-market-report>.
- [3] "The World's First Hydroelectric Power Plant Began Operation," America's Story from America's Library, Library of Congress. Accessed May 24, 2016. [http://www.americaslibrary.gov/jb/gilded/jb\\_gilded\\_hydro\\_1.html](http://www.americaslibrary.gov/jb/gilded/jb_gilded_hydro_1.html).
- [4] U.S. Energy Information Administration. Monthly Energy Review. U.S. Department of Energy. Accessed February 3, 2016. <http://www.eia.gov/totalenergy/data/monthly/>.
- [5] U.S. Census. Series G171-182. Power Electric Energy, Production by Type of Prime Move: 1902 to 1945 (in MWh). Accessed May 24, 2016. <http://www2.census.gov/prod2/statcomp/documents/HistoricalStatisticsoftheUnitedStates1789-1945.pdf>
- [6] U.S. Energy Information Administration. Form 860\_US Capacity by Generator Unit\_Y1891-Y2014. U.S. Department of Energy. October 21, 2015. Accessed February 3, 2016. <http://www.eia.gov/electricity/data/eia860/index.html>
- [7] Bracmort, K., A. Vann, and C.V. Stern. July 7, 2015. Hydropower: Federal and Nonfederal Investment. CRS Report R42579. Congressional Research Service. Accessed May 3, 2016. <https://www.fas.org/sgp/crs/misc/R42579.pdf>
- [8] U.S. Energy Information Administration, Form EIA-860 Annual Electric Generator Report, and Form EIA-860M. Hydropower has a long history in the United States. July 8, 2011. Accessed May 24, 2016. <http://www.eia.gov/todayinenergy/detail.cfm?id=2130>
- [9] Federal Energy Regulatory Commission, Energy Infrastructure Updates (2011-2015). Accessed February 3, 2016. <http://www.ferc.gov/legal/staff-reports.asp>
- [10] U.S. Energy Information Administration. Annual Energy Review (Table of generation, electric power Sector, 1949-2011). U.S. Department of Energy. Accessed May 3, 2016. <http://www.eia.gov/totalenergy/data/annual/xls/stb0802b.xls>
- [11] U.S. Energy Information Administration. Electric Power Monthly, 2012-present. U.S. Department of Energy. Accessed May 3, 2016. <http://www.eia.gov/electricity/monthly/index.cfm>.
- [12] "How Hydropower Works," U.S. Department of Energy. Accessed May 24, 2016, <http://energy.gov/eere/water/how-hydropower-works>.
- [13] U.S. Energy Information Administration. Monthly Energy Review. U.S. Department of Energy. Accessed February 3, 2016. <http://www.eia.gov/totalenergy/data/monthly/>.
- [14] U.S. Army Corps of Engineers. 2011. U.S. Army Corps of Engineers Civil Works Program: Five-Year Development Plan. Accessed May 24, 2016. <http://www.usace.army.mil/Missions/CivilWorks/Budget.aspx>.
- [15] "Hydroelectric Powerplants Listed by Others," U.S. Bureau of Reclamation. Accessed May 24, 2016. <http://www.usbr.gov/power/data/faclothr.html>.
- [16] Oldham, K., "Decommissioning dams—costs and trends," WaterPower and Dam Construction. 2009. Accessed on May 3, 2016. <http://www.waterpowermagazine.com/features/featuredecommissioning-dams-costs-and-trends/>
- [17] National Hydropower Asset Assessment Program. "NHAAP FY15 Hydropower Plant Summary." Unpublished, 2015.
- [18] Hawaiian Electric Company, Inc. 2015. 2014 Renewable Portfolio Standard Status Report. Hawaiian Electric Company Inc., Hawai'i Electric Light Company Inc., Maui Electric Company, Limited. Accessed May 23, 2016. <https://www.mauielectric.com/about-us/key-performance-metrics/renewable-energy>
- [19] McManamay, R.A., C.O. Oigbokie, S.C. Kao, and M.S. Bevelhimer, "Classification of US hydropower dams by their modes of operation," River Research and Applications, 2016. DOI: <http://dx.doi.org/10.1002/rra.3004>.

- [20] “National Inventory of Dams,” Corps (U.S. Army Corps of Engineers). Accessed May 3, 2016. <http://geo.usace.army.mil/pgis/f?p=397:1:0>.
- [21] Hadjerioua, Boualem, Yaxing Wei, and Shih-Chieh Kao. 2012. An Assessment of Energy Potential at Non-powered Dams in the United States. GPO DOE/EE-0711. U.S. Department of Energy Wind and Water Power Program, Washington, DC. Accessed May 3, 2016. <http://energy.gov/eere/water/downloads/assessment-energy-potential-non-powered-dams-united-states>
- [22] Sale, M.J., S-C. Kao, M. Ashfaq, D.P. Kaiser, R. Martinez, C. Webb, and Y. Wei. October 2012. Assessment of the Effects of Climate Change on Federal Hydropower. ORNL/TM-2011/251. Oak Ridge National Laboratory, Oak Ridge, TN. Accessed April 29, 2016. <http://nhaap.ornl.gov/content/climate-change-impact-assessment>
- [23] Held, I.M. and B.J. Soden, “Robust Responses of the Hydrological Cycle to Global Warming,” *Journal of Climate*, Volume 19, 5686–5699, March 17, 2006. Accessed May 3, 2016. DOI: <http://dx.doi.org/10.1175/JCLI3990.1>.
- [24] Canadian National Energy Board. 2013. Canada’s Energy Future 2013: Energy Supply and Demand Projections to 2035. N° de cat. NE2-12/2013F-PDF, ISSN 2292-1729. Accessed May 3, 2016. <https://www.neb-one.gc.ca/nrg/ntgrtd/fttr/2013/2013nrgftr-eng.pdf>.
- [25] North American Electric Reliability Corporation, NERC Regions and Balancing Authorities (Maps), as of October 21, 2015. NNERC. Accessed May 24, 2016. [www.nerc.com/AboutNERC/keyplayers/Pages/default.aspx](http://www.nerc.com/AboutNERC/keyplayers/Pages/default.aspx)
- [26] “Western watches markets,” Western Area Power Administration. Accessed May 24, 2016. <https://www.wapa.gov/newsroom/NewsFeatures/2013/Pages/watches-market.aspx>
- [27] National Hydropower Asset Assessment Program, Oak Ridge National Laboratory. Accessed May 24, 2016. <http://nhaap.ornl.gov/>.
- [28] Stori, V. 2013. Environmental Rules for Hydropower in State Renewable Portfolio Standards. Clean Energy States Alliance, Montpelier, VT (US). Accessed May 3, 2016. <http://www.cesa.org/resource-library/resource/environmental-rules-for-hydropower-in-state-renewable-portfolio-standards>.
- [29] U.S. Energy Information Administration. April 2013. Updated Capital Cost Estimates for Utility Scale Electricity Generating Plants. Independent Statistics & Analysis, U.S. Energy Information Administration, U.S. Department of Energy, Washington, DC. Accessed May 3, 2016. <http://www.eia.gov/forecasts/capitalcost/>.
- [30] International Renewable Energy Agency. June 2012. Renewable Energy Technologies: costs analysis series. Volume 1: Power Sector, Issue 3/5. International Renewable Energy Agency, Abu Dhabi, United Arab Emirates. Accessed May 3, 2016. [http://www.irena.org/documentdownloads/publications/re\\_technologies\\_cost\\_analysis-hydropower.pdf](http://www.irena.org/documentdownloads/publications/re_technologies_cost_analysis-hydropower.pdf).
- [31] U.S. Energy Information Administration. May 29, 2012. Seasonal hydroelectric output drives down wholesale electricity prices in the West. U.S. Energy Information Administration, U.S. Department of Energy, Washington, DC. Accessed May 3, 2016. <http://www.eia.gov/todayinenergy/detail.cfm?id=6450#>.
- [32] U.S. Energy Information Administration. January 12, 2015. Wholesale power prices across the country in 2014. U.S. Energy Information Administration, U.S. Department of Energy, Washington, DC. Accessed May 3, 2016. <http://www.eia.gov/todayinenergy/detail.cfm?id=19531>.
- [33] Maloney, P. “PURPA: still generating electricity, but with a few worms in the mix. The barrel: the essential perspective on global energy,” October 29, 2012. S&P Global, Platts. Accessed May 24, 2016. [http://blogs.platts.com/2012/10/09/purpa\\_today/](http://blogs.platts.com/2012/10/09/purpa_today/).
- [34] “Detailed Summary Maps, Renewable Portfolio Standards,” Database of State Incentives for Renewables and Efficiency. Accessed May 3, 2016. <http://www.dsireusa.org/resources/detailed-summary-maps/>.
- [35] Graf, W.L. 2006. Downstream Hydrologic and Geomorphic Effects of Large Dams on American Rivers. *Geomorphology* Volume 79, Issue 3-4, 2006, pages 336-360.
- [36] Liermann, C.R., C. Nilsson, J. Robertson, and R.Y. Ng., “Implications of Dam Obstruction for Global Freshwater Fish Diversity, *BioScience*, Volume 62, Issue 6, pages 539-548. DOI: <http://dx.doi.org/10.1525/bio.2012.62.6.5>.

- [37] Costanza, R., Pérez-Maqueo, O., Martinez, M. L., Sutton, P., Anderson, S. J., and Mulder, K. 2008. The value of coastal wetlands for hurricane protection. *AMBIO: A Journal of the Human Environment*, 37(4), 241-248.
- [38] Jager, H.I. and B.T. Smith, "Sustainable Reservoir Operation: Can We Generate Hydropower and Preserve Ecosystem Values?" *River Research and Applications*, Volume 24, Issue 3, pages 340-352, March 2008, DOI: <http://dx.doi.org/10.1002/rra.1069>.
- [39] Poff, N.L. and D.D. Hart, "How dams vary and why it matters for the emerging science of dam removal," *BioScience*, August 2002, Volume 52, Issue 8, pages 659-668.
- [40] Powers, S.M., J.P. Julian, M.W. Doyle, and E.H. Stanley, "Retention and Transport of Nutrients in a Mature Agricultural Impoundment." *Journal of Geophysical Research, Biogeosciences* 2013, Volume 118, Issue 1, pages 91-103.
- [41] Čada, G.F., "A Review of Studies Relating to the Effects of Propeller-Type Turbine Passage on Fish Early Life Stages." *North American Journal of Fisheries Management* 10: 418-426. Volume 10, Issue 4, 1990. Accessed May 3, 2016. <http://www.tandfonline.com/doi/abs/10.1577/1548-8675%281990%29010%3C0418%3AAAROSRT%3E2.3.CO%3B2?journalCode=ujfm20>.
- [42] Poff, N.L., J.D. Allan, M.B. Bain, J.R. Karr, K.L. Prestegard, B. Richter, R. Sparks, and J. Stromberg, "The natural flow regime: a new paradigm for riverine conservation and restoration," *BioScience*, 1997, Volume 47, pages 769-784.
- [43] Opdam, P., J. Verboom, and R. Pouwels, "Landscape cohesion: an index for the conservation potential of landscapes for biodiversity," *Landscape Ecology*, March 2003, Volume 18, Issue 2, pp 113-126. DOI: <http://dx.doi.org/10.1023/A:1024429715253>.
- [44] Hopping, P., P. March, T. Brice, and J. Cybularz. January 1997. Update on development of auto-venting turbine technology. Accessed May 3, 2016. [http://www.researchgate.net/publication/242113133\\_Update\\_on\\_Development\\_of\\_Auto-Venting\\_Turbine\\_Technology](http://www.researchgate.net/publication/242113133_Update_on_Development_of_Auto-Venting_Turbine_Technology).
- [45] McManamay, R. A., D.J. Orth, C.A Dolloff, and M.A. Cantrell, "Gravel addition as a habitat restoration technique for tailwaters," *North American Journal of Fisheries Management*, Volume 30, Issue 5, 2010 pages 1238-1257. DOI: <http://dx.doi.org/10.1577/M10-007.1>.
- [46] "Managing Reservoir Sediment," *Western Water and Power Solution Bulletin*, No. 8, 2008, U.S. Bureau of Reclamation. Accessed April 9, 2016. <https://www.usbr.gov/research/docs/updates/pre-2012/Managing-Reservoir-Sediment.pdf>.
- [47] Ward, J.V. and J.A. Stanford, "Ecological Connectivity in Alluvial River Ecosystems and Its Disruption By Flow Regulation," *Regulated Rivers: Research and Management*, 1995, Volume 11, pages 105-119. DOI: <http://dx.doi.org/10.1002/rrr.3450110109>.
- [48] Bessert, M. L., and G. Orti. 2008. Genetic effects of habitat fragmentation on blue sucker populations in the upper Missouri River (*Cyprinus elongatus* Lesueur, 1918). *Conservation Genetics*, 9(4), 821-832.
- [49] Larson, K.B., S.E. Niehus, J.D. Tagestad, K.D. Ham, S.H. Geerlofs, and M.C. Richmond. 2014. The Integrated Basin-Scale Opportunity Assessment Initiative: Pilot Assessment for the Deschutes River Basin. PNNL-23197. Prepared for the U.S. Department of Energy, Washington, D.C., by the Pacific Northwest National Laboratory, Richland, Washington. Accessed May 3, 2016. [http://basin.pnnl.gov/Content/reports/2014/BSOA\\_Deschutes\\_final\\_report\\_Public\\_Disclaimer.pdf](http://basin.pnnl.gov/Content/reports/2014/BSOA_Deschutes_final_report_Public_Disclaimer.pdf).
- [50] McManamay, R.A., N. Samu, S.C. Kao, M.S. Bevelhimer, S.C. Hetrick, "A multi-scale spatial approach to address environmental impacts of small hydropower development," *Environmental Management*, Volume 55, 2015, pages 217-243. DOI: <http://dx.doi.org/10.1007/s00267-014-0371-2>.
- [51] Coutant, C. C. and R. R. Whitney. 2000. Fish behavior in relation to passage through hydropower turbines: a review. *Trans. Am. Fish. Soc.*, 129: 351-380.
- [52] Pracheil, B.M., G.E. Mestl, and M.A. Pegg, "Movement Through Dams Facilitates Population Connectivity in a Large River," *River Research and Applications*, April 1, 2014. Accessed May 25, 2016. DOI: <http://dx.doi.org/10.1002/rra.2751>.
- [53] Pracheil, B.M., C.R. DeRolph, M.P. Schramm, and M.S. Bevelhimer, "A fish-eye view of riverine hydropower systems: the current understanding of the biological response to fish passage," *Reviews in Fish Biology and Fisheries*, January 13, 2016. DOI <http://dx.doi.org/10.1007/s11160-015-9416-8>.

- [54] Odeh, M.. 1999. A Summary of Environmentally Friendly Turbine Design Concepts. DOE/ID/13741. U.S. Department of Energy, Idaho Operations Office. Accessed May 24, 2016. <http://www1.eere.energy.gov/wind/pdfs/doewater-13741.pdf>.
- [55] Hogan, T.W., G.F. Cada, and S.V. Amaral. 2014. The Status of Environmentally Enhanced Hydropower Turbines, Fisheries, 39:4, 164-172, Publisher: Taylor & Francis. Accessed May 3, 2016. <http://www.tandfonline.com/loi/ufsh20#.VyjAxpG8Xg>.
- [56] Johnson, G.E. and D.D. Dauble, "Surface Flow Outlets to Protect Juvenile Salmonids Passing through Hydropower Dams." Reviews in Fisheries Science, Volume 14, Issue 3, 2006, pages 213-244. DOI: <http://dx.doi.org/10.1080/10641260600864023>.
- [57] Office of Technologies Assessment. 1995. Fish Passage Technologies: Protection at Hydropower Facilities. OTA-ENV-641. U.S. Congress, Office of Technologies Assessment. Accessed May 3, 2016. <http://www.scribd.com/doc/127919022/4101294-Fish-Passage-Technologies-Protection-at-Hydropower-Facilities#scribd>.
- [58] Irwin, E.R. and M.C. Freeman. 2002. Proposal for adaptive management to conserve biotic integrity in a regulated segment of the Tallapoosa River, Alabama, U.S.A. Conservation Biology 16: 1212-1222.
- [59] Walters, C. August 1986. Adaptive Management of Renewable Resources. MacMillan Publishing Company, New York, N.Y.
- [60] Owen, D. and C. Apse, "Trading Dams," University of California Davis Law Review, 2015, Volume 48, pages 1043-1109.
- [61] U.S. Bureau of Reclamation. March 2011. Hydropower Resource Assessment at Existing Reclamation Facilities. U.S. Department of Interior, Bureau of Reclamation, Power Resources Office. Denver, CO. Accessed May 24, 2016. <http://www.usbr.gov/power/AssessmentReport/>.
- [62] Montgomery, Watson, Harza. 2009. Hydropower Modernization Initiative, Phase I, Needs and Opportunities Evaluation and Ranking. U.S. Army Corps of Engineers Northwest Division Hydroelectric Design Center, Contract No. W9127N-08-D-0003, Task Order 0013.
- [63] U.S. Bureau of Reclamation. March 2012. Site Inventory and Hydropower Energy Assessment of Reclamation Owned Conduits: Supplement to the "Hydropower Resource Assessment at Existing Reclamation Facilities Report." Accessed May 24, 2016. <http://www.usbr.gov/power/CanalReport/>.
- [64] Sale, M.J., N. Bishop, K. Johnson, A. Bailey, A. Frank, S. Reiser, and B.T. Smith. August 2014. Opportunities for New Energy Development in Water Conduits. ORNL/TM-2014/272, Oak Ridge National Laboratory, Oak Ridge, TN.
- [65] Kao, S-C., R.A. McManamay, K.M. Stewart, N.M. Samu, B. Hadjerioua, S.T. DeNeale, D. Yeasmin, M. Fayzul, K. Pasha, A.A. Oubeidillah, and B.T. Smith. 2014. New Stream-Reach Development: A Comprehensive Assessment of Hydropower Energy Potential in the United States. GPO DOE/EE-1063. U.S. Department of Energy Wind and Water Power Program, Washington, DC. Accessed April 26, 2016. <http://nhaap.ornl.gov/nsd>
- [66] U.S. Department of Energy. February 2015. Pumped Storage and Potential Hydropower from Conduits. Report to Congress. U.S. Department of Energy, Washington, DC. Accessed May 24, 2016. <http://energy.gov/eere/water/downloads/pumped-storage-and-potential-hydropower-conduits>.
- [67] "Hydropower Sustainability Assessment Protocol, 2010," International Hydropower Association. Accessed May 3, 2016. <http://www.hydropower.org/Protocol.aspx>.
- [68] Sale, M.J., D. Hall, and J. Keil. 2016. Low Impact Hydropower Institute Certification Handbook, 2nd Edition. Low Impact Hydropower Institute, Harrington Park, NJ. Accessed May 3, 2016. <http://lowimpacthydro.org/>.
- [69] Ela, E.; Gevorgian, V.; Tuohy, A.; Kirby, B.; Milligan, M.; O'Malley, M. "Market Designs for the Primary Frequency Response Ancillary Service -- Part I: Motivation and Design" Journal Name: IEEE Transactions on Power Systems; Journal Volume: 29; Journal Issue: 1, January 2014, Accessed May 3, 2016. DOI: 10.1109/TPWRS.2013.2264942. <http://www.osti.gov/scitech/biblio/1121511>.
- [70] "Electricity Generating Capacity," last modified January 3, 2013. U.S. Energy Information Administration, U.S. Department of Energy. Accessed May 4, 2016. <https://www.EIA.gov/electricity/capacity/>.



- [71] Lew, D.; G. Brinkman; E. Ibanez; A. Florita; M. Hummon; B-M. Hodge; G. Stark; J. King; S.A. Lefton; N. Kumar; D. Agan; S. Venkataraman and G.Jordan. September 2013. Western Wind and Solar Integration Study Phase 2. NREL/TP-5500-55588. National Renewable Energy Laboratory, Golden, CO (US); RePPAE, Wexford, PA (US); Intertek-APTECH, Houston, TX (US); GE Energy, Atlanta, GA (US). Accessed April 28, 2016. [http://primo-pmtna01.hosted.exlibrisgroup.com/Pubs:PUBS:NREL\\_HORIZON79670](http://primo-pmtna01.hosted.exlibrisgroup.com/Pubs:PUBS:NREL_HORIZON79670).
- [72] “Guide to Market Oversight—Glossary,” Updated: March 15, 2016. Federal Energy Regulatory Commission. Accessed May 4, 2016. <http://www.ferc.gov/market-oversight/guide/glossary.asp>.
- [73] Federal Energy Regulatory Commission, FERC (1996), “Promotion of wholesale competition through open access nondiscriminatory transmission services by public utilities and recovery of stranded costs by public utilities and transmitting utilities,” Order No. 888, FERC Stats. & Regs. Issued April 1996. Accessed May 24, 2016. <http://www.ferc.gov/legal/maj-ord-reg/land-docs/order888.asp>.
- [74] North American Electric Reliability Corporation. 2015. Glossary of Terms Used in NERC Reliability Standards. (updated May 17, 2016). North American Electric Reliability Corporation, Washington, D.C. (US). Accessed May 24, 2016. [http://www.nerc.com/files/glossary\\_of\\_terms.pdf](http://www.nerc.com/files/glossary_of_terms.pdf).
- [75] Undrill, J. (2004) “Power plant operational issues relating to grid operation,” presented at IEEE Xplore Conference: Power Engineering Society General Meeting, 2004. IEEE. Accessed May 4, 2016. DOI: <http://dx.doi.org/10.1109/PES.2004.1373182>.
- [76] M. Piekutowski, A. Halley and S. Denholm, “The Future Role of Hydro Plant in Maximizing the Integration of Wind Generation,” Wind Engineering (2012): Multi-Science Publishing Company; Vol. 36; No.1; pp 19-34. DOI: <http://dx.doi.org/10.1260/0309-524X.36.1.19>.
- [77] Eto, J.H.; J. Undrill; P. Macken; R. Daschmans; B. Williams; B. Haney; R. Hunt; J. Ellis; H.F. Illian; C.A. Martinez; M. O’Malley; K. Coughlin; and K. Hamachi LaCommare. 2010. Use of Frequency Response Metrics to Assess the Planning and Operating Requirements for Reliable Integration of Variable Renewable Generation. LBNL-4142E. Lawrence Berkeley National Laboratory, Berkeley, CA (US). Accessed April 28, 2016. <http://eetd.lbl.gov/publications/use-of-frequency-response-metrics-to->.
- [78] E. Ela, V. Gevorgian, A. Tuohy, B. Kirby, M. Milligan, M. O’Malley, “Market Designs for the Primary Frequency Response Ancillary Service—Part I: Motivation and Design,” IEEE Transactions on Power Systems. Vol. 29(1), January 2014: pp. 421-431. NREL Report No. JA-5D00-55356. Accessed May 24, 2016. DOI: <http://dx.doi.org/10.1109/TPWRS.2013.2264942>.
- [79] North American Electric Reliability Corporation, “Essential Reliability Services Task Force Measures Framework Report,” December 17, 2015. Accessed May 24, 2016. [http://www.nerc.com/Other/Pages/Essential-Reliability-Services-Task-Force-\(ERSTF\).aspx](http://www.nerc.com/Other/Pages/Essential-Reliability-Services-Task-Force-(ERSTF).aspx).
- [80] Key, T. 2013. Quantifying the Value of Hydro-power in the Electric Grid: Final Report. Electric Power Research Institute report 1023144. Electric Power Research Institute, Palo Alto, CA (US). Accessed April 29, 2016. <http://www.epri.com/abstracts/Pages/Product-Abstract.aspx?ProductId=00000000001023144>.
- [81] “U.S. Army Corps of Engineers Northwestern Division, dataquery,” accessed May 23, 2016, <http://www.nwd-wc.usace.army.mil/cgi-bin/dataquery.pl>.
- [82] Western Area Power Administration, released to Western Electricity Coordinating Council for Transmission Expansion Planning Policy Committee database. Accessed May 23, 2016, <https://www.wecc.biz/TransmissionExpansionPlanning/Pages/Datasets.aspx>.
- [83] Koritarov, V.; H. Veselka; J. Gasper; B. Bethke; A. Botterud; J. Wang; M. Mahalik; Z. Zhou; C. Milostan; J. Feltes; Y. Kazachkov; T. Guo; G. Liu; B. Trouille; P. Donalek; K. King; E. Ela; B. Kirby; I. Krad and V. Gevorgian. 2014. Modeling and Analysis of Value of Advanced Pumped Storage Hydropower in the United States. Argonne National Laboratory Report ANL/DIS-14/7. Argonne National Laboratory, Argonne, IL (US). Accessed April 29, 2016. <https://anl.app.box.com/s/timqpu2moj7zw4t8t5ta9xpck14tta63>.

- [84] R.K. Fisher, J. Koutnik, L. Meier, V. Loose, K. Engels, and T. Beyer. "A Comparison of Advanced Pumped Storage Equipment Drivers in the US and Europe," presented at HydroVision 2012, July 18, 2012, Louisville, KY. <http://dx.doi.org/10.13140/2.1.1082.4967>.
- [85] J. Pfeifenberger. "Transmission Investment Trends and Planning Challenges," presented at EEI Transmission and Wholesale Markets School, Madison, WI, August 8, 2012. Accessed April 29, 2016. [http://www.brattle.com/system/publications/pdfs/000/004/432/original/Transmission\\_Investment\\_Trends\\_and\\_Planning\\_Challenges\\_Pfeifenberger\\_Aug\\_8\\_2012\\_EEI.pdf?1378772105](http://www.brattle.com/system/publications/pdfs/000/004/432/original/Transmission_Investment_Trends_and_Planning_Challenges_Pfeifenberger_Aug_8_2012_EEI.pdf?1378772105).
- [86] Midcontinent Independent System Operator. 2014. MTEP14 MVP Triennial Review: A 2014 review of the public policy, economic, and qualitative benefits of the Multi-Value Project Portfolio. Midcontinent Independent System Operator, Inc. (MISO), Carmel, IN (US). Accessed April 29, 2016. <https://www.misoenergy.org/Library/Repository/Study/Candidate%20MVP%20Analysis/MTEP14%20MVP%20Triennial%20Review%20Report.pdf>.
- [87] Milligan, M.; B. Kirby; T. Acker; M. Ahlstrom; B. Frew; M. Goggin; W. Lasher; M. Marquis and D. Osborn. 2015. Review and Status of Wind Integration and Transmission in the United States: Key Issues and Lessons Learned. NREL/TP-5D00-61911. National Renewable Energy Laboratory, Golden, CO (US). Accessed May 24, 2016. [http://primo-pmtna01.hosted.exlibrisgroup.com/Pubs:PUBS:NREL\\_HORIZON98071](http://primo-pmtna01.hosted.exlibrisgroup.com/Pubs:PUBS:NREL_HORIZON98071).
- [88] National Renewable Energy Laboratory. Data extracted from ABB Energy Velocity Suite (paid subscription only). <http://new.abb.com/enterprise-software/energy-portfolio-management/market-intelligence-services/velocity-suite>.
- [89] J. Bakke, Z. Zhou, and S. Mudgal. 2013. Manitoba Hydro Wind Synergy Study. Midcontinent Independent System Operator, Inc. (MISO), Carmel, IN (US). Accessed April 28, 2016. [https://www.misoenergy.org/\\_layouts/MISO/ECM/Download.aspx?ID=160821](https://www.misoenergy.org/_layouts/MISO/ECM/Download.aspx?ID=160821).
- [90] State of Hawaii Department of Business, Economic Development, and Tourism. 2015. Hawaii Energy Facts and Figures. State of Hawaii Department of Business, Economic Development, and Tourism, Honolulu, HI, (US). Accessed April 29, 2016. <http://energy.hawaii.gov/resources/hawaii-state-energy-office-publications>.
- [91] State of Hawaii Department of Business, Economic Development, and Tourism. <http://energy.hawaii.gov/>.
- [92] Personal communications with Jeff Williams, Power Cost Equalization Program Manager, Alaska Energy Authority.
- [93] U.S. Energy Information Administration. 2013. Form EIA-860: Annual Electric Generator Report. U.S. Energy Information Administration. Washington, D.C. (US). Accessed May 2, 2016. [http://www.EIA.gov/electricity/capacity/xls/existing\\_gen\\_units\\_2011.xls](http://www.EIA.gov/electricity/capacity/xls/existing_gen_units_2011.xls).
- [94] GE Energy. 2010. Western Wind and Solar Integration Study. Subcontract Report NREL/SR-550-47434. GE Energy, Schenectady, NY (US). Accessed May 24, 2016. [http://primo-pmtna01.hosted.exlibrisgroup.com/Pubs:PUBS:NREL\\_HORIZON86161](http://primo-pmtna01.hosted.exlibrisgroup.com/Pubs:PUBS:NREL_HORIZON86161).
- [95] Acker, T.. 2011a. IEA Wind Task 24 Integration of Wind and Hydropower Systems; Volume 1: Issues, Impacts, and Economics of Wind and Hydropower Integration. NREL Report No. TP-5000-50181. Northern Arizona University on behalf of the National Renewable Energy Laboratory U.S. Department of Energy Wind and Hydropower Program, Flagstaff, AZ (US). Accessed April 28, 2016. <http://energy.gov/eere/wind/wind-program-newsletter-first-quarter-2012>.
- [96] Ela, E.; M. Milligan; and B. Kirby. 2011. Operating Reserves and Variable Generation. A comprehensive review of current strategies, studies, and fundamental research on the impact that increased penetration of variable renewable generation has on power system operating reserves. NREL Report No. TP-5500-51978. National Renewable Energy Laboratory, Golden, CO (US). Accessed May 24, 2016. [http://primo-pmtna01.hosted.exlibrisgroup.com/Pubs:PUBS:NREL\\_HORIZON83046](http://primo-pmtna01.hosted.exlibrisgroup.com/Pubs:PUBS:NREL_HORIZON83046).
- [97] Exeter Associates, Inc., and GE Energy. 2012. PJM Renewable Integration Study Task Report: Review of Industry Practice and Experience in the Integration of Wind and Solar Generation. Prepared for PJM Interconnection, LLC by Exeter Associates, Inc., Columbia, MD (US) and GE Energy, Atlanta, GA (US). Accessed April 28, 2016. <http://www.pjm.com/committees-and-groups/subcommittees/irs/pris.aspx>.

- [98] Palchak, D., and Denholm, P. 2014. Impact of Generator Flexibility on Electric System Costs and Integration of Renewable Energy. Tech. Report TP-6A20-62275. National Renewable Energy Laboratory, Golden, CO (US). Accessed April 29, 2016. <http://www.energy.gov/eere/analysis/downloads/impact-generator-flexibility-electric-system-costs-and-integration-renewable>.
- [99] Acker, T. and C. Pete. 2012. Western Wind and Solar Integration Study: Hydropower Analysis. NREL Report No. SR-5500-53098. National Renewable Energy Laboratory, Golden, CO (US). Accessed May 24, 2016. [http://primo-pmtna01.hosted.exlibrisgroup.com/Pubs:PUBS:NREL\\_HORIZON83601](http://primo-pmtna01.hosted.exlibrisgroup.com/Pubs:PUBS:NREL_HORIZON83601).
- [100] J. Bakke, Z. Zhou, and S. Mudgal. 2013. Manitoba Hydro Wind Synergy Study. Midcontinent Independent System Operator, Inc. (MISO), Carmel, IN (US). Accessed April 28, 2016. [https://www.misoenergy.org/\\_layouts/MISO/ECM/Download.aspx?ID=160821](https://www.misoenergy.org/_layouts/MISO/ECM/Download.aspx?ID=160821).
- [101] Acker, T. 2011b. IEA Wind Task 24 Integration of Wind and Hydropower Systems; Volume 2: Participant Case Studies. NREL Report No. TP-5000-50182. Northern Arizona University on behalf of the National Renewable Energy Laboratory U.S. Department of Energy Wind and Hydropower Program, Flagstaff, AZ (US). Accessed April 28, 2016. <http://energy.gov/eere/wind/wind-program-newsletter-first-quarter-2012>.
- [102] E. Ibanez, T. Magee, M. Clement, G. Brinkman, M. Milligan, and E. Zagona, "Enhancing hydropower modeling in variable generation studies," *Energy, The International Journal* 74 (2014): pgs. 518-528. Accessed May 24, 2016. DOI: <http://dx.doi.org/10.1016/j.energy.2014.07.017>.
- [103] North American Electric Reliability Corporation, "Written Statement of Gerry Cauley, President and CEO, North American Electric Reliability Corporation, to the Quadrennial Energy Review Task Force, February 4, 2016". February 4, 2016. Accessed May 23, 2016. <http://www.nerc.com/news/testimony/Pages/Cauley-Participates-on-DOE-Quadrennial-Energy-Review-Panel.aspx>.
- [104] U.S. Energy Information Administration (EIA). 2015a. Annual Energy Outlook 2015, April, DOE/EIA-0383(2015). U.S. Energy Information Administration, Washington, D.C. (US). Accessed May 2, 2016. <http://www.eia.gov/forecasts/aeo/>.
- [105] Bolinger, M. 2013. Revisiting the Long-Term Hedge Value of Wind Power in an Era of Low Natural Gas Prices. LBNL-6103E. Lawrence Berkeley National Laboratory, Berkeley, CA (US). Accessed May 24, 2016. <https://emp.lbl.gov/publications/revisiting-long-term-hedge-value-wind-power-era-low-natural-gas-prices>.
- [106] Borenstein, Severin, and Bushnell, James. 2015. The U.S. Electricity Industry after 20 Years of Restructuring. Energy Institute at Haas School of Business, Berkeley, CA. Accessed May 24, 2016. <http://www.nber.org/papers/w21113>.
- [107] Federal Energy Regulatory Commission (FERC). 2014e. Q3 2014 Brookfield White Pine Hydro LLC transactions. FERC Electronic Quarterly Reports. Federal Energy Regulatory Commission, Washington D.C. (US). Accessed May 5, 2016. <http://eqrreportviewer.ferc.gov>.
- [108] "Wholesale Electricity and Natural Gas Market Data," last modified April 28, 2016. U.S. Energy Information Administration. U.S. Department of Energy. Accessed May 4, 2016. <http://www.EIA.gov/electricity/wholesale>.
- [109] "Electric Power Markets: National Overview," Updated February 29, 2016. Federal Energy Regulatory Commission. Accessed May 4, 2016. <http://www.ferc.gov/market-oversight/mkt-electric/overview.asp>.
- [110] Northwest PowerPool (NWPP). 2015. Northwest PowerPool Area Assessment of Reliability and Adequacy 2015 Summer Operating Conditions. Northwest PowerPool. March, 2015. Accessed May 3, 2016. <http://www.nwpp.org/documents/Seasonal-Assessments/Summer-Assessment-2015.pdf>.
- [111] Patton, D.B., P. LeeVanSchaick, and J. Chen. 2014. 2013 State of the Market Report for the New York ISO Markets. Potomac Economics, Market Monitoring Unit for the New York ISO, Fairfax, VA (US). Accessed May 23, 2016. [https://www.potomaceconomics.com/index.php/markets\\_monitored/new\\_york\\_iso](https://www.potomaceconomics.com/index.php/markets_monitored/new_york_iso).
- [112] "Wholesale Electricity and Natural Gas Market Data," 2014 data. Last modified April 28, 2016. Accessed May 4, 2016. <http://www.EIA.gov/electricity/wholesale>.

- [113] U.S.-Canada Power System Outage Task Force. 2004. U.S.-Canada Power System Outage Task Force, Final Report on the August 2003 Blackout in the United States and Canada: Causes and Recommendations. United States and Canada. Accessed May 3, 2016. <http://energy.gov/sites/prod/files/oeprod/DocumentsandMedia/BlackoutFinal-Web.pdf>.
- [114] Federal Energy Regulatory Commission (FERC) (2003) “Docket No. ER03-291, Order Accepting Application”. February, 2003. Accessed May 23, 2016. <https://www.gpo.gov/fdsys/pkg/FR-2003-01-08/html/03-376.htm>.
- [115] Electric Reliability Council of Texas (ERCOT). 2012. ERCOT Nodal Protocols Section 6: Adjustment Period and Real-Time Operations. Electric Reliability Council of Texas, Austin, TX (US). Accessed May 2, 2016. [http://www.ercot.com/content/mktrules/protocols/current/06-100112\\_Nodal.doc](http://www.ercot.com/content/mktrules/protocols/current/06-100112_Nodal.doc).
- [116] Loose, V.W. 2011. Quantifying the Value of Hydropower in the Electric Grid: Role of Hydropower in Existing Markets. SAND2011-1009. Sandia National Laboratories, Albuquerque, NM (US). Accessed May 4, 2016. <http://prod.sandia.gov/techlib/access-control.cgi/2011/111009.pdf>.
- [117] Federal Energy Regulatory Commission. WECC reporting regions. Western Electricity Coordinating Council, Salt Lake City, UT (US). Accessed May 3, 2016. <http://www.ferc.gov/market-oversight/mkt-electric/wecc-subregions.pdf>.
- [118] Final Rule by the Federal Energy Regulatory Commission Issued October 20, 2011, Frequency Regulation Compensation in the Organized Wholesale Power Markets. Code of Federal Regulation 18 CFR Part 35 (2011): Docket Nos. RM11-7-000 and AD10-11-000; Order No. 755. Accessed May 5, 2016. <http://www.ferc.gov/whats-new/comm-meet/2011/102011/E-28.pdf>.
- [119] “2016/2017 RPM Base Residual Auction Results,” PJM Interconnection. PJM DOCS #753726. Accessed May 4, 2016. <http://www.pjm.com/-/media/markets-ops/rpm/rpm-auction-info/2016-2017-base-residual-auction-report.ashx>.
- [120] “Installed Capacity: View Strip Auction Summary,” New York Independent System Operator (NYISO). Accessed May 4, 2016. [http://icap.nyiso.com/ucap/public/auc\\_view\\_strip\\_detail.do](http://icap.nyiso.com/ucap/public/auc_view_strip_detail.do).
- [121] Federal Energy Regulatory Commission (FERC) (2014a. OE Energy Market Snapshot, Central Version—September 2014 Data. Office of Enforcement, Federal Energy Regulatory Commission, Washington D.C. (US). Accessed May 24, 2016. <http://www.ferc.gov/market-oversight/mkt-snp-sht/mkt-snp-sht.asp>.
- [122] Federal Energy Regulatory Commission (FERC) (2014b. OE Energy Market Snapshot, East Version—September 2014 Data. Office of Enforcement, Federal Energy Regulatory Commission, Washington D.C. (US). Accessed May 24, 2016. <http://www.ferc.gov/market-oversight/mkt-snp-sht/mkt-snp-sht.asp>.
- [123] Order Confirming and Approving Rate On A Final Basis by the Federal Energy Regulatory Commission. Issued October 16, 2014, 149 FERC ¶ 61,043 (2014): Docket Nos. EF14-5-000, EF14-5-001. Accessed May 24, 2016. <https://www.ferc.gov/whats-new/comm-meet/2014/ca10-16-14.asp>.
- [124] Electric Reliability Council of Texas. 2014. About the Operating Reserve Demand Curve and Wholesale Electric Prices. Electric Reliability Council of Texas, Austin, TX (US). Accessed May 4, 2016 <https://www.hks.harvard.edu/hepg/Papers/2014/ORDCUpdate-FINAL.pdf>.
- [125] “Wholesale Electricity and Natural Gas Market Data,” October 2015. Last modified April 28, 2016. Accessed May 4, 2016. <http://www.EIA.gov/electricity/wholesale>.
- [126] Shie-Jie, D., Y. Shen, and H. Sun. “Optimal Scheduling of Hydro-Electric Power Generation with simultaneous Participation in Multiple Markets,” presented at 2006 IEEE PES Power Systems Conference and Exposition, Oct. 29 2006 - Nov. 1 2006. DOI: 10.1109/PSCE.2006.296160. Accessed May 25, 2016. <http://dx.doi.org/10.1109/PSCE.2006.296160>.
- [127] S. Niu and M. Insley, “On the Economics of Ramping Rate Restrictions at Hydro Power Plants: Balancing Profitability and Environmental Costs,” Energy Economics (2013): 39, 39-52, September 2013. Accessed May 25, 2016. DOI: <http://dx.doi.org/10.1016/j.eneco.2013.04.002>.



- [128] Notice of proposed rulemaking by the Federal Energy Regulatory Commission on Issued September 17, 2015, Settlement Intervals and Shortage Pricing in Markets Operated by Regional Transmission Organizations and Independent System Operators. Code of Federal Regulation 18 CFR Part 35 (2015) Docket No. RM15-24-000. Accessed May 4, 2016. <https://www.ferc.gov/whats-new/comm-meet/2015/091715/E-1.pdf>.
- [129] North American Electric Corporation (NERC). 2013. Special Protection Systems (SPS) and Remedial Action Schemes (RAS): Assessment of Definition, Regional Practices, and Application of Related Standards. Revision 0.1, April 2013.
- [130] D. Aswani, R. Clarke-Johnson, and G. Runyan. 2011. The Impact of Hydroelectric Power and Other Forms of Generation on Grid Frequency Stability for the WECC Region. American Governor Company, Warminster, PA (US). Accessed May 4, 2016. <https://www.americangovernor.com/wp-content/uploads/2013/04/Impact-of-Hydropower-on-Grid-Stability-HV2011.pdf>.
- [131] Notice of Inquiry by the Federal Energy Regulatory Commission on Issued February 18, 2016, Essential Reliability Services and the Evolving Bulk-Power System - Primary Frequency Response. Docket No. RM16-6-000 (2016). Accessed May 4, 2016. <http://www.ferc.gov/whats-new/comm-meet/2016/021816/E-2.pdf>.
- [132] Ashton, L. "Dam Management Plan Makes the Most of Columbia River's Water." Los Angeles Times. March 18, 2001. Accessed May 4, 2016. <http://articles.latimes.com/2001/mar/18/local/me-39196>.
- [133] Ela, E., M. Milligan, A. Bloom, A. Botterud, A. Townsend, and T. Levin. 2014. Evolution of Wholesale Electricity Market Design with Increasing Levels of Renewable Generation. National Renewable Energy Laboratory, Golden, CO (US). NREL/TP-5D00-61765. Accessed May 2, 2016. <http://www.nrel.gov/docs/fy14osti/61765.pdf>.
- [134] "Negative wholesale electricity prices occur in RTOs." Accessed May 4, 2016. <http://www.EIA.gov/todayinenergy/detail.cfm?id=6730>. **Note** The original chart and associated discussion of the frequency of negative prices in RTOs originally published on June 18, 2012 has been removed because of incomplete data from an external source.
- [135] Loutan, C. "ERSTF, Loads and Resources Balance". Presented at NERC Conference, Vancouver, B.C., September 17, 2014—September 18, 2014.
- [136] California Independent System Operator (CAISO). 2015. Q1 2015 Report on Market Issues and Performance. California Independent System Operator (CAISO), Folsom, CA. Accessed May 24, 2016. <http://caiso.com/market/Pages/MarketMonitoring/MarketIssuesPerformanceReports/Default.aspx>.
- [137] Bird, L.; J. Cochran, and X. Wang. 2014. Wind and Solar Energy Curtailment: Experience and Practices in the United States. NREL/TP-6A20-60983. Accessed May 24, 2016. [http://primo-pmtna01.hosted.exlibrisgroup.com/Pubs:PUBS:NREL\\_HORIZON97383](http://primo-pmtna01.hosted.exlibrisgroup.com/Pubs:PUBS:NREL_HORIZON97383).
- [138] Midcontinent Independent System Operator, Inc. 2015. Bi Directional EAR. Seams Management Working Group. January, 2015. Midcontinent Independent System Operator, Inc., Carmel, IN (US). Accessed May 3, 2016. [https://www.misoenergy.org/\\_layouts/MISO/ECM/Redirect.aspx?ID=191104](https://www.misoenergy.org/_layouts/MISO/ECM/Redirect.aspx?ID=191104).
- [139] Order On Tariff Revisions by the Federal Energy Regulatory Commission on Issued October 16, 2014, 149 FERC ¶ 61,042 (2014): docket No. ER14-2574-000. Accessed May 4, 2016. [http://elibrary.ferc.gov/idmws/docket\\_sheet.asp?DOCKET=ER14-2574](http://elibrary.ferc.gov/idmws/docket_sheet.asp?DOCKET=ER14-2574).
- [140] Xu, L. and D. Tretheway. 2014. Flexible Ramping Products, Incorporating FMM and EIM: Draft Final Proposal. California Independent System Operator, Infrastructure Development Group, Folsom, CA (US). Accessed May 3, 2016. [https://www.caiso.com/Documents/DraftFinalProposal\\_FlexibleRampingProduct\\_includingFMM-EIM.pdf](https://www.caiso.com/Documents/DraftFinalProposal_FlexibleRampingProduct_includingFMM-EIM.pdf).
- [141] Sale, M.J. 2011. Outlook for the U.S. Army Corps of Engineers Hydropower Program. M.J. Sale & Associates. 2011-WRO-P-02. Accessed May 3, 2016. <http://www.iwr.usace.army.mil/Portals/70/docs/iwrreports/2011-WRO-P-02.pdf>.
- [142] U.S. Library of Congress, Congressional Research Service. Hydropower: Federal and Non-Federal Investment by Bracmort, K. C. V. Stern, and A. Vann. 7-5700. 2013.
- [143] National Research Council, "Corps of Engineers Water Resources Infrastructure: Deterioration, Investment, or Divestment?" The National Academies Press (2012), DOI: <http://dx.doi.org/10.17226/13508>.



- [144] Energy Information Administration. “PresideInt’s proposed budget calls for strategic review of government’s role in TVA.” *Today in Energy*. May 7, 2013. Accessed May 4, 2016. <http://www.EIA.gov/todayinenergy/detail.cfm?id=11151>.
- [145] Lazard (2014). “TVA Strategic Assessment” Lazard Freres & Co. January 2014. Accessed May 24, 2016. <http://www.sec.gov/Archives/edgar/data/1376986/000137698614000019/a8-klazardreportxxjune2014.htm>.
- [146] Southwestern Power Administration (2009). *Integrated System 2009 Power Repayment Studies and Rate Proposal*.
- [147] “Current rates.” Alaska Electric Light and Power. 2015. Accessed January 21, 2016. <http://www.aelp.com/Rates/ourrates.htm>.
- [148] Fay, G.; Melendez, A.V. and C. West. 2013. *Alaska Energy Statistics 1960-2011 Final Report*. Institute of Social and Economic Research, University of Alaska Anchorage, Anchorage, AK (US). Accessed May 2, 2016. [http://iser.uaa.alaska.edu/Publications/2013\\_12-AlaskaEnergyStatistics2011Report\\_Final\\_2014-04-30.pdf](http://iser.uaa.alaska.edu/Publications/2013_12-AlaskaEnergyStatistics2011Report_Final_2014-04-30.pdf).
- [149] The Alaska Center for Energy and Power, University of Alaska Fairbanks. 2014. *An Alaska-British Columbia Transmission Intertie*. The Alaska Center for Energy and Power, Fairbanks AK (US). Accessed May 2, 2016. <http://www.akenergyauthority.org/Content/Policy/RegionalPlanning/Documents/AK-BCTransIntertieReport033114.pdf>.
- [150] Electric Power Systems, Inc. (2013). “Alaska Energy Authority Alaska Railbelt Transmission Plan Draft Review.” Electric Power Systems, Inc. November, 2013.
- [151] Global Energy Concepts, LLC. 2006. *A Catalog of Potential Sites for Renewable Energy in Hawaii*. Global Energy Concepts, LLC. Kirkland, WA (US). Accessed May 3, 2016. <http://energy.hawaii.gov/resources/hawaii-state-energy-office-publications>.
- [152] “Renewable Portfolio Standard (Hawaii),” Database of State Incentives for Renewables and Efficiency. Updated June 10, 2015. Accessed May 25, 2016. <http://programs.dsireusa.org/system/program/detail/606>
- [153] “Columbia River Treaty 2014/2024,” U.S. Army Corps of Engineers and Bonneville Power Administration (U.S. Entity). Accessed May 24, 2016. <http://www.crt2014-2024review.gov/>.
- [154] U.S. Entity (2013b). “U.S. Entity Regional Recommendation for the Future of the Columbia River Treaty after 2024”. December, 2013. Accessed May 24, 2016. <http://www.crt2014-2024review.gov/RegionalDraft.aspx>.
- [155] Kirkpatrick, K. (2013). “The Columbia River Treaty’s Canadian Entitlement: The Role of Liberalized and Integrated North American Electricity Markets in a New Calculation”. *Washington Journal of Environmental Law & Policy*. Vol 3:2013. December, 2013. Accessed May 24, 2016. <http://www.crt2014-w024review.gov/Files/Columbia%20River%20Treaty%20Review%20-%20Fact%20Sheet%20-%20Canadian%20Entitlement-FOR%20PRINT.pdf>.
- [156] “Territory Served,” PJM Interconnection. Accessed May 4, 2016. <http://www.pjm.com/about-pjm/who-we-are/territory-served.aspx>.
- [157] “Electric Power Markets: New England (ISO-NE),” Federal Energy Regulatory Commission. Updated March 10, 2016. Accessed May 4, 2016. <http://www.ferc.gov/market-oversight/mkt-electric/new-england.asp>.
- [158] Energy Information Administration. “Age of electric power generators varies widely.” *Today in Energy*. June, 2011. Accessed May 4, 2016. <http://www.EIA.gov/todayinenergy/detail.cfm?id=1830>.
- [159] Heeter, J., Belyeu, K., Kuskova-Burns., K. (2014). *Status and Trends in the U.S. Voluntary Green Power Market (2013 Data)*. NREL/TP-6A20-63052. Accessed May 24, 2016. [http://primo-pmtna01.hosted.exlibrisgroup.com/Pubs:PUBS:NREL\\_HORIZON98848](http://primo-pmtna01.hosted.exlibrisgroup.com/Pubs:PUBS:NREL_HORIZON98848).
- [160] Green-e. 2013. *Clarification on Treatment of Repowered Hydropower Facilities under Version 2.3 of the Green-e Energy National Standard*. Green-e Energy, San Francisco, CA (US). Accessed May 4, 2016. [http://www.green-e.org/docs/energy/Energy\\_Repowered\\_Hydro\\_Clarification\\_2013.pdf](http://www.green-e.org/docs/energy/Energy_Repowered_Hydro_Clarification_2013.pdf).
- [161] “Monroe Hydro Project,” Natel Energy. 2016. Accessed May 4, 2016. <http://www.natelenergy.com/monroe-hydro-project/>.
- [162] U.S. Environmental Protection Agency. 2010. *Guide to Purchasing Green Power Renewable Electricity, Renewable Energy Certificates, and On-Site Renewable Generation*. DOE/EE-0307. Environmental Protection Agency, Washington D.C. (US). Accessed May 24, 2016. <https://www.epa.gov/greenpower/guide-purchasing-green-power>.

- [163] “Cross-State Air Pollution Rule (CSAPR).” U.S. Environmental Protection Agency. Accessed May 4, 2016. <http://www.epa.gov/crossstaterule/>.
- [164] A Rule by the Environmental Protection Agency on October 23, 2015, Carbon Pollution Emission Guidelines for Existing Stationary Sources: Electric Utility Generating Units. Vol. 80 Friday, No. 205 October 23, 2015, Book 2 of 2 Books, Pages 64661–65120. Accessed May 4, 2016. <https://www.federalregister.gov/articles/2015/10/23/2015-22842/carbon-pollution-emission-guidelines-for-existing-stationary-sources-electric-utility-generating>.
- [165] Pacific Northwest Utilities Conference Committee (PNUCC). 2014. The Northwest and 111(d). Pacific Northwest Utilities Conference Committee, Portland, OR (US). Accessed May 3, 2016. <http://pnucc.org/sites/default/files/The%20Northwest%20and%20111d%202014%201009%20final.pdf>.
- [166] Chupka, M.; M. Celebi, and K. Spees. 2014. Hydropower and the EPA Section 111(d) Proposal. The Brattle Group, Washington, D.C. (US). Accessed May 4, 2016. [http://www.brattle.com/system/publications/pdfs/000/005/112/original/Hydropower\\_and\\_the\\_EPA\\_Section\\_111\(d\)\\_Proposal.pdf?1422314120](http://www.brattle.com/system/publications/pdfs/000/005/112/original/Hydropower_and_the_EPA_Section_111(d)_Proposal.pdf?1422314120).
- [167] American Public Power Association. 2014. Power Plants are not Built on Spec: 2014 Update. American Public Power Association, Arlington, VA (US). Accessed May 4, 2016. [http://www.publicpower.org/files/PDFs/Power\\_Plants\\_Not\\_Built\\_on\\_Spec\\_2014.pdf](http://www.publicpower.org/files/PDFs/Power_Plants_Not_Built_on_Spec_2014.pdf).
- [168] Wiser, R., M. Bolinger, G. Barbose, N. Darghouth, B. Hoen, A. Mills, S. Weaver, K. Porter, M. Buckley, F. Oteri, and S. Tegen. August 2014. 2013 Wind Technologies Market Report. DOE/GO-102014-4459, LBNL-6809E. Lawrence Berkeley National Laboratory, Berkeley, CA (US). Accessed May 3, 2016. <https://emp.lbl.gov/publications/2013-wind-technologies-market-report>.
- [169] Harper, J.P., M.D. Karcher, and M. Bolinger. September 20, 2007. Wind Project Financing Structures: A Review & Comparative Analysis. LBNL-63434. Lawrence Berkeley National Laboratory, Berkeley, CA (US). Accessed May 25, 2016. <https://publications.lbl.gov/islandora/object/ir%3A152156>.
- [170] Wiser, R.H., and E.P. Kahn. 1996. Alternative Windpower Ownership Structures: Financing Terms and Project Costs. LBNL-38921. Lawrence Berkeley National Laboratory, Berkeley, CA (US). Accessed May 3, 2016. <https://emp.lbl.gov/publications/alternative-windpower-ownership>.
- [171] Sawyer, M. (2014). “Red Rock Hydroelectric Project,” presented at National Hydropower Association Hydropower Finance Summit. October 2, 2014.
- [172] USACE (2014). “Federal Interest Rates for Corps of Engineers Projects for Fiscal Year 2015”. United States Army Corps of Engineers. October, 2015. Accessed May 25, 2016. <http://planning.usace.army.mil/toolbox/guidance.cfm?Option=Type&BL=None&Type=EGM&Sort=YearDesc>.
- [173] Bonneville Power Administration (BPA). 2014. BPA Financial Reserves. Bonneville Power Administration, Portland, OR (US). Accessed May 4, 2016. [https://www.bpa.gov/Finance/FinancialPublicProcesses/AccessstoCapital/July\\_16\\_2014\\_Financial\\_Reserves\\_Workshop.pdf](https://www.bpa.gov/Finance/FinancialPublicProcesses/AccessstoCapital/July_16_2014_Financial_Reserves_Workshop.pdf).
- [174] Collins, J. “Project Development and Financing Mahoning Creek - A Case Study,” presented at National Hydropower Association Hydropower Finance Summit. October 2, 2014.
- [175] Ocwieja, M. “Financing a Small Hydro Portfolio,” presented at National Hydropower Association Hydropower Finance Summit. October 2, 2014.
- [176] Bolinger, M.. May 2014. An Analysis of the Costs, Benefits, and Implications of Different Approaches to Capturing the Value of Renewable Energy Tax Incentives. LBNL-6610E. Lawrence Berkeley National Laboratory, Berkeley, CA (US). Accessed May 23, 2016. <https://emp.lbl.gov/publications/analysis-costs-benefits-and-0>.
- [177] Schwabe, P., K. Cory, and J. Newcomb. 2009. Renewable Energy Project Financing: Impacts of the Financial Crisis and Federal Legislation. Technical Report NREL/TP-6A2-44930. National Renewable Energy Laboratory, Golden, CO (US). Accessed May 24, 2016. [http://primo-pmtna01.hosted.exlibrisgroup.com/Pubs:PUBS:NREL\\_HORIZON90557](http://primo-pmtna01.hosted.exlibrisgroup.com/Pubs:PUBS:NREL_HORIZON90557).
- [178] Mendelsohn, M., and C. Kreycik. 2012. Federal and State Structures to Support Financing Utility-Scale Solar Projects and the Business Models Designed to Utilize Them. NREL/TP-6A20-48685. National Renewable Energy Laboratory, Golden, CO (US). Accessed May 3, 2016. <http://www.energy.gov/eere/slsc/downloads/federal-and-state-structures-support-financing-utility-scale-solar-projects-and>.

- [179] Bolinger, M.; R.H. Wiser and N.R. Darghouth. Preliminary Evaluation of the Impact of the Section 1603 Treasury Grant Program on Renewable Energy Deployment in 2009. Lawrence Berkeley National Laboratory, Berkeley, CA (US). Accessed May 2, 2016. <http://eetd.lbl.gov/publications/preliminary-evaluation-of-the-impact->.
- [180] Kreycik, C. 2010. Financing Renewable Energy at Government Facilities. National Renewable Energy Laboratory, Golden, CO (US). Accessed May 3, 2016. <https://financere.NREL.gov/finance/content/financing-renewable-energy-government-facilities>.
- [181] U.S. Department of Energy. 2014b. Draft Guidance for EAct 2005 Section 242 Program. Accessed January 21, 2016. <http://energy.gov/eere/water/articles/energy-department-seeks-feedback-draft-guidance-hydroelectric-production>.
- [182] Myers, E. "Tax-Advantaged Financing for Hydroelectric Facilities: American Municipal Power, Inc. Case Study," presented at National Hydropower Association Hydropower Finance Summit. June, 2013.
- [183] A. Ang, V. Bhansali, and Y. Xing, "Build America Bonds," *The Journal of Fixed Income* (2010): Vol. 20, No. 1. Summer, 2010. Accessed May 25, 2016. <http://www.nber.org/papers/w16008>.
- [184] Ordinance No. 8607 by the City of Lawrence Kansas on December 21, 2010, An Ordinance Authorizing the issuance for the City of Lawrence, Kansas of industrial revenue bonds, and repealing Ordinance No. 8599 and Ordinance No. 8604. Accessed May 5, 2016. [http://lawrenceks.org/assets/ecodev/2012\\_Abatement\\_Report/Appendix/IRBs/Bowersock\\_Dam\\_IRBs](http://lawrenceks.org/assets/ecodev/2012_Abatement_Report/Appendix/IRBs/Bowersock_Dam_IRBs).
- [185] Friedman, J. and S. Fazell. 2012. US-China Market Review Summer 2012. American Council on Renewable Energy, Washington, D.C. (US). Accessed May 3, 2016. [http://www.naseo.org/Data/Sites/1/documents/committees/financing/resources/qecb/QECBs\\_and\\_the\\_Potential\\_to\\_Finance\\_Clean\\_Energy.pdf](http://www.naseo.org/Data/Sites/1/documents/committees/financing/resources/qecb/QECBs_and_the_Potential_to_Finance_Clean_Energy.pdf).
- [186] Allen, J.W., and Britt, J.J. "Department of Energy Announces New Loan Guarantee Program for Renewable Energy and Energy Efficiency Projects." *Renewable Energy Outlook*, March 7, 2014. Accessed May 2, 2016. <http://www.renewableenergyoutlook.com/2014/05/07/department-of-energy-announces-new-loan-guarantee-program-for-renewable-energy-and-energy-efficiency-projects/>.
- [187] Hitchcock, S.M. "BETC: Oregon's Tax Incentive to Reduce Energy Costs." Saalfeld Griggs PC (2012). Accessed May 3, 2016. <http://www.sglaw.com/betc-oregons-tax-incentive-to-reduce-energy-costs/>.
- [188] Templeton, A. (2011). "Oregon Irrigators Embrace Hydropower." Published August 5, 2011. Accessed January 21, 2016. <http://www.opb.org/news/article/oregon-irrigators-move-into-the-hydro-business/>.
- [189] Federal Energy Regulatory Commission and State of Colorado (2010). "Memorandum of Understanding between the Federal Energy Regulatory Commission and the State of Colorado through the Governor's Energy Office to Streamline and Simplify the Authorization of Small Scale Hydropower Projects." August 2010. Accessed May 4, 2016. <https://www.ferc.gov/legal/mou/mou-co.pdf>.
- [190] Colorado Energy Office. Revised October 2015. "Colorado Small Hydropower Handbook." Colorado Energy Office. Accessed May 24, 2016. <https://www.colorado.gov/pacific/energyoffice/atom/32666>.
- [191] Donaldson, D. "House Approves Five More Years of Renewable Energy." *Renewable Energy Alaska Project*. 2012. Accessed May 4, 2016. <http://alaskarenewableenergy.org/tag/renewable-energy-grant-fund/>.
- [192] Energy Information Administration (EIA). 2014. Annual Energy Review. Electricity net generation: electric power sector, back to 1949. Energy Information Administration, Washington D.C. (US). US DOE. September 27, 2012; and Electric Power Monthly. Net generation by energy source: total (all sectors). Accessed May 24, 2016. <http://www.eia.gov/totalenergy/data/annual/>.
- [193] Sale, M.J., N.A. Bishop, Jr., S.L. Reiser, K. Johnson, A.C. Bailey, A. Frank, and B.T. Smith. 2014. Opportunities for Energy Development in Water Conduits: A Report Prepared in Response to Section 7 of the Hydropower Regulatory Efficiency Act of 2013. ORNL/TM-2014/272. Prepared for the U.S. Department of Energy by the ORNL Water Power Technologies Team. September.

- [194] International Finance Corporation. February 2015. Hydroelectric Power : A Guide for Developers and Investors. International Finance Corporation, World Bank Group. Accessed May 25, 2016. [http://www.ifc.org/wps/wcm/connect/topics\\_ext\\_content/ifc\\_external\\_corporate\\_site/ifc+sustainability/learning+and+adapting/knowledge+products/publications/hydroelectric\\_power\\_a\\_guide\\_for\\_developers\\_and\\_investors](http://www.ifc.org/wps/wcm/connect/topics_ext_content/ifc_external_corporate_site/ifc+sustainability/learning+and+adapting/knowledge+products/publications/hydroelectric_power_a_guide_for_developers_and_investors)
- [195] American Rivers, et al. 2013a. A New Paradigm for Collaborative Development of Small Hydropower Projects, A Step-by-Step Process. American Rivers, Community Hydropower Consulting, and Bradley Floretin. Accessed May 3, 2016. <http://www.smallhydro.co/#!/resources/c3nu>.
- [196] "Integrated Licensing Process (ILP)." Federal Energy Regulatory Commission. Updated March 3, 2015. Accessed May 25, 2016. <https://www.ferc.gov/industries/hydropower/gen-info/licensing/ilp.asp>.
- [197] Meier, P., P. Blaszczyk, C. Harris, and K. Gilbert. 2010. "Project Development: From Concept to Construction: Steps to Developing a Hydro Project." Hydro Review, volume 29, Issue 3. Accessed May 4, 2016. <http://www.hydroworld.com/articles/hr/print/volume-29/issue-3/articles/project-development.html>.
- [198] Federal Energy Regulatory Commission (FERC). 2001. Report on Hydroelectric Licensing Policies, Procedures, and Regulations—Comprehensive Review and Recommendations Pursuant to Section 603 of the Energy Act of 2000. Federal Energy Regulatory Commission, Washington D.C. (US). Accessed May 3, 2016. [http://www.ferc.gov/legal/maj-ord-reg/land-docs/ortc\\_final.pdf](http://www.ferc.gov/legal/maj-ord-reg/land-docs/ortc_final.pdf).
- [199] Opperman, J.J., J. Royte, J. Banks, L.R. Day and C. Apse, "The Penobscot River, Maine, USA: a Basin-Scale Approach to Balancing Power Generation and Ecosystem Restoration," Ecology and Society (2011): Volume 16, Issue 3, Article 7. <http://dx.doi.org/10.5751/ES-04117-160307>. Accessed May 4, 2016. <http://www.ecologyandsociety.org/vol16/iss3/art7/>.
- [200] Penobscot River Restoration Trust. (n.d.) Penobscot River Restoration Trust, fact sheet. Augusta, ME (US). Accessed May 25, 2016. <http://www.penobscotriver.org/content/4011/fact-sheet-and-faq-s>.
- [201] Larson K.B., G.E. Johnson, J.D. Tagestad, C.A. Duberstein, M.S. Bevelhimer, R.A. McManamay, C.R. DeRolph, and S.H. Geerlofs. 2014. The Integrated Basin-Scale Opportunity Assessment Initiative: Scoping Assessment for the Connecticut River Basin, Final Report. PNNL-23778. Pacific Northwest National Laboratory, Richland, WA (US). Accessed May 3, 2016. [http://basin.pnnl.gov/Content/reports/Connecticut/BSOA\\_Ph1\\_ScopingAssessment\\_CT\\_final\\_PNNL-23778\\_23Oct2014.pdf](http://basin.pnnl.gov/Content/reports/Connecticut/BSOA_Ph1_ScopingAssessment_CT_final_PNNL-23778_23Oct2014.pdf).
- [202] Stredwick, T. May 19, 2015. "Balancing Unit Efficiency and Fish Passage." Hydro Review, volume 34, Issue 4. Accessed May 25, 2016. <http://www.hydroworld.com/articles/hr/print/volume-34/issue-4/articles/balancing-unit-efficiency-and-fish-passage.html>.
- [203] Oregon Water Resources Department, 2013. Accessed May 25, 2016. <http://www.oregon.gov/owrd/pages/index.aspx>.
- [204] Hartmann, J., D. Harrison, J. Opperman, and R. Gill. 2013. The Next Frontier of Hydropower Sustainability: Planning at the System Scale. The Nature Conservancy, Arlington, VA (US). Accessed May 4, 2016. <http://www.conservationgateway.org/ConservationPractices/Freshwater/WaterInfrastructure/Pages/hydroatscale.aspx>.
- [205] J. Opperman, G. Grill, and J. Hartmann, "The Power of Rivers: Finding balance between energy and conservation in hydropower development," The Nature Conservancy (2015): Washington, D.C. (US). Accessed May 25, 2016. DOI: <http://dx.doi.org/10.13140/RG.2.1.5054.5765>.
- [206] Interstate Renewable Energy Council (IREC). 2013. Model Interconnection Procedures, 2013 Edition. Interstate Renewable Energy Council, Latham, NY (US). Accessed May 4, 2016. <http://www.irecusa.org/model-interconnection-procedures/>.
- [207] DOE, DOI, Army Corps, 2010. Memorandum of Understanding for Hydropower Among The Department Of Energy, The Department of the Interior and The Department of the Army. Accessed May 25, 2016. <http://energy.gov/eere/water/downloads/hydropower-memorandum-understanding>.



- [208] Federal Energy Regulatory Commission (FERC). 2011. Ideas for Implementing and Participating in the Integrated Licensing Process (ILP), Tools for Industry, Agencies, Tribes, Non-Governmental Organizations, Citizens, and FERC Staff, Version 2.0. Federal Energy Regulatory Commission, Washington D.C. (US). Accessed May 3, 2016. <http://www.ferc.gov/industries/hydropower/gen-info/licensing/ilp/eff-eva.asp>.
- [209] “What is an Electric Generator?” Artinaid, 2013. Accessed April 29, 2015. <http://www.artinaid.com/2013/04/what-is-an-electric-generator/>.
- [210] “Overview of Small Hydro Construction Operation,” French Development Enterprises, LLC. 2014.
- [211] “Innovative Technologies,” International Energy Agency Small Scale Hydropower Task Force. Accessed April 28, 2016. <http://www.small-hydro.com/Programs/innovative-technologies.aspx>.
- [212] American Society of Mechanical Engineers Hydropower Technical Committee. The Guide to Hydropower Mechanical Design. Kansas City: PenWell Hydro Group, 1996.
- [213] Feng, J.; R. Li; R. Liang; and X. Shen, “Eco-environmentally friendly operational regulation: an effective strategy to diminish the TDG supersaturation of reservoirs,” *Hydrology and Earth System Sciences*, 18(3), 1213-1223 (2014). Accessed April 28, 2016. DOI: <http://dx.doi.org/10.5194/hessd-10-14355-2013>.
- [214] “Fish-Friendly Turbine Making a Splash in Water Power,” U.S. Department of Energy, last modified October 21, 2011. Accessed May 25, 2016. <http://energy.gov/articles/fish-friendly-turbine-making-splash-water-power>.
- [215] “Sunset Passage and Energy Project Fact Sheet,” Snohomish County Public Utilities District. April 2014. Accessed May 25, 2016. <http://www.snopud.com/?p=1956>.
- [216] Bishop, N.; D. Linke; C. Vansant; C. Alsbet; J. Anders; A. Grovue; S. Hill-Nelson; K. Johnson; B. Smith; D. Youlen; and K. Young. 2015. New Pathways for Hydropower: Getting Hydropower Built—What Does it Take? ORNL/TM-2015/48. Oak Ridge National Laboratory (ORNL), Oak Ridge, TN (US). Accessed May 25, 2016. <http://hydropower.ornl.gov/media/publications/>.
- [217] Infrastructure Fact Sheet, 2009. American Society of Civil Engineers. Accessed April 28, 2016. [http://www.infrastructurereportcard.org/2009/sites/default/files/RC2009\\_dams.pdf](http://www.infrastructurereportcard.org/2009/sites/default/files/RC2009_dams.pdf).
- [218] Fisher, R.K.; J.R. Degnan; and G.F. Wachter. “Rehabilitation & Upgrading of Existing Hydroelectric Plans Employing New Design Techniques.” Presented at American Power Conference, Chicago, Illinois, April 18–20, 1983.
- [219] Richmond, M.C. and P. Romero-Gomez, “Fish Passage through Hydropower Turbines: Simulating Blade Strike using the Discrete Element Method,” 27th IAHR Symposium on Hydraulic Machinery and Systems, Montreal, Canada, September 22–26, 2014. IOP Conf. Series: Earth and Environmental Science 22 (2014): 062010. Accessed May 25, 2016. DOI: <http://dx.doi.org/10.1088/1755-1315/22/6/062010>.
- [220] “Dam Safety 101: Top Issues Facing the Dam Community.” 2016. Association of State Dam Safety Officials. Accessed May 25, 2016. <http://www.dam-safety.org/news/?p=c0fdade4-ab98-4679-be22-e3d7f14e124f>
- [221] Technical Manual for Dam Owners: Impacts of Plants on Earthen Dams. 2005. FEMA 534. Federal Emergency Management Agency, Washington, D.C. (US). Accessed April 28, 2016, <https://www.fema.gov/media-library/assets/documents/1027>.
- [222] “About NERC>Key Players>Regional Entities.” North American Electric Reliability Corporation. As of July 25, 2012. Accessed May 25, 2016. [www.nerc.com/AboutNERC/keyplayers/Pages/Regional-Entities.aspx](http://www.nerc.com/AboutNERC/keyplayers/Pages/Regional-Entities.aspx).
- [223] North American Electric Reliability Corporation. “2003 Blackout Final Report.” April 1, 2004. Accessed May 25, 2016. <http://www.nerc.com/pa/rmm/ea/Pages/Blackout-August-2003.aspx>.
- [224] Frantzis, L. and Graham, S. “Utility Business Models in Solar: Opportunities and Trends.” Presentation at Intersolar North America. ©2011. Accessed June 21, 2016. [http://www.navigant.com/-/media/WWW/Site/Insights/Energy/Utility\\_Business\\_Models.pdf](http://www.navigant.com/-/media/WWW/Site/Insights/Energy/Utility_Business_Models.pdf).
- [225] “Reservoir Operations Study.” Tennessee Valley Authority ©2004. Accessed June 21, 2016. [http://152.87.4.80/environment/reports/ros\\_eis/index.htm](http://152.87.4.80/environment/reports/ros_eis/index.htm).
- [226] Wunderlich, W. O. 1991. Heat exchange between a water surface and the atmosphere.



- [227] Welt, F., Hachem, S., and Kahawita, R. Edited by Broch, E., Lysne, D.K., Flatabo, N., and HellandHansen, E. "Integration of river water temperature constraints within real time operation of hydroplants." Paper presented at HYDROPOWER '97, Trondheim, Norway, June 30-July 2, 1997.
- [228] Labadie, J.W., "Optimal operation of multi-reservoir systems: State-of-the-art review," *Journal of Water Resources Planning and Management* 130 (2004): 93-111. Accessed June 21, 2016. [http://dx.doi.org/10.1061/\(ASCE\)0733-9496\(2004\)130:2\(93\)](http://dx.doi.org/10.1061/(ASCE)0733-9496(2004)130:2(93)).
- [229] Sullivan, G.P.; R. Pugh; A. P. Melendez; and W.D. Hunt. 2010. Operations and Maintenance Best Practices: A Guide to Achieving Operational Efficiency. Federal Energy Management Program, U.S. Department of Energy, Washington, D.C. (US). Accessed May 25, 2016. <http://energy.gov/eere/femp/downloads/operations-and-maintenance-best-practices-guide>.
- [230] Oak Ridge National Laboratory, MESA Associates, Inc., and Hydro Performance Processes, Inc. August 2, 2012. Hydropower Advancement Project, Best Practice Catalog, Machine Condition Monitoring, Revision 2.0. Accessed May 25, 2016. <http://hydro.power.ornl.gov/research/hydropower/best-practices/>.
- [231] U.S. Department of Energy, "Global Energy Storage Database." c2016. Accessed June 22, 2016. <http://www.energystorageexchange.org>.
- [232] Botterud, A.; T. Levin; and V. Koritarov. 2014. Pumped Storage Hydropower: Benefits for Grid Reliability and Integration of Variable Renewable Energy. ANL/DIS-14/10. Argonne National Laboratory (ANL), Argonne, IL (US). Accessed April 28, 2016, <http://www.ipd.anl.gov/anlpubs/2014/12/106380.pdf>.
- [233] "International Energy Statistics," U.S. Energy Information Administration. U.S. Department of Energy. Accessed May 2, 2016. <http://www.eia.gov/cfapps/ipdbproject/iedindex3.cfm?tid=2&pid=82&aid=7&cid=regions&syid=2004&eyid=2012&unit=MK>.
- [234] Koritarov, V.; L. Guzowski; J. Feltes; Y. Kazachkov; B. Gong; B. Trouille; and P. Donalek. 2013a. Modeling Adjustable Speed Pumped Storage Hydro Units Employing Doubly-Fed Induction Machines. ANL/DIS-13/06. Argonne National Laboratory (ANL), Argonne, IL (US). Accessed May 25, 2016. <https://anl.box.com/s/4qs5ieljm6q1op97pg367s117p91dorh>.
- [235] Technical Analysis of Pumped Storage and Integration with Wind Power in the Pacific Northwest. 2009. U.S. Army Corps of Engineers, Northwest Division, Hydroelectric Design Center. Accessed May 25, 2016. <http://www.hydro.org/wp-content/uploads/2011/07/PS-Wind-Integration-Final-Report-without-Exhibits-MWH-3.pdf>.
- [236] Aubert, S.; P. Steimer; S. Linder; and C. Hillberg. "Variable Speed Pumped Storage with Converter-Fed Synchronous Machines (CFSM)—A High Value in Grids with Large Penetration of Wind and Solar Generation." HYDRO 2014, Lake Como, Italy, October 13–15, 2014.
- [237] Koritarov, V.; L. Guzowski; J. Feltes; Y. Kazachkov; B. Gong; B. Trouille; P. Donalek; and V. Gevorgian. 2013b. Modeling Ternary Pumped Storage Units. ANL/DIS-13/07. Argonne National Laboratory (ANL), Argonne, IL (US). Accessed May 25, 2016. <https://anl.box.com/s/52hqlvletrpc087y4ds2wutgn2ds13xt>.
- [238] Koritarov, V.; T. Guo; E. Ela; B. Trouille; J. Feltes; I. Krad; C. and Clark. "Operational Capabilities and Valuation of Benefits Provided by Advanced Pumped Storage Hydropower Technologies." Presentation at HydroVision, Portland, OR, July 2015.
- [239] Hadjerioua, B.; R. Martinez; H A. Shanafield III; Y. Wei; J. D. McCulla; Norm Bishop; A. M. Alsharif, and B. T. Smith. 2012. National Resource Assessment of Pumped Storage Hydropower. Oak Ridge National Laboratory (ORNL), Oak Ridge, TN (US).
- [240] Hadjerioua, B.; N. Bishop; R. Uria-Martinez; and E. Hopping. 2014. "Evaluation of the Feasibility and Viability of m-PSH in the U.S. - Preliminary first case study, Coal Mine." Oak Ridge National Laboratory (ORNL), Oak Ridge, TN (US).
- [241] "Riverbank Minnesota, LLC; Notice of Preliminary Permit Application Accepted for Filing and Soliciting Comments, Motions To Intervene, and Competing Applications." Federal Energy Regulatory Commission. April 9, 2010. Accessed May 25, 2016. <https://www.federalregister.gov/articles/2010/04/09/2010-8065/riverbank-minnesota-llc-notice-of-preliminary-permit-application-accepted-for-filing-and-soliciting>.

- [242] Tedrick, S. "Two billion dollar underground hydroelectric facility a possibility just outside of Granite Falls." *Advocate Tribune*. April 15, 2010. Accessed May 25, 2016. <http://www.granitefallsnews.com/article/20100415/NEWS/304159936>.
- [243] "Gravity Power Grid-Scale Electricity Storage System," Gravity Power, LLC (n.d.), accessed May 2, 2016, <http://www.launchpnt.com/portfolio/energy/grid-scale-electricity-storage/>.
- [244] Grid Energy Storage. 2013. U.S. Department of Energy. Accessed May 25, 2016. <http://energy.gov/oe/downloads/grid-energy-storage-december-2013>
- [245] Patel, S. "The Big Picture: Storage Snapshot," Power: Business and Technology for the Global Generation Industry since 1882. April 30, 2014. Accessed May 2, 2016, <http://www.powermag.com/the-big-picture-storage-snapshot>.
- [246] Issued Preliminary Permits for Pumped Storage Projects Map. Federal Energy Regulatory Commission. April 1, 2016. Pumped Storage Projects: Existing and Proposed Projects. Accessed May 25, 2016. <http://www.ferc.gov/industries/hydropower/gen-info/licensing/pump-storage.asp>.
- [247] Kauai Island Utility Cooperative. Accessed June 22, 2016. <http://website.kiuc.coop/>.
- [248] Akhil, A.A.; G. Huff; A.B. Currier; B.C. Kaun; D.M. Rastler; S.B. Chen; A.L. Cotter; D.T. Bradshaw; and W.D. Gauntlett. 2013. DOE/EPRI 2013 Electricity Storage Handbook in Collaboration with NRECA. SAND2013-5131. Sandia National Laboratories (SNL), Albuquerque, NM (US). Accessed April 28, 2016, <http://energy.gov/sites/prod/files/2013/08/f2/ElecStorageHndbk2013.pdf>.
- [249] "State Land Board Approves KIUC Energy Storage Plan." Kauai Island Utility Cooperative. November 14, 2014. Accessed May 25, 2016. <http://kauai.coopwebbuilder.com/content/state-land-board-approves-kiuc-energy-storage-plan>.
- [250] Vishwanathan, V.; M. Kintner-Meyer; P. Balducci; and C. Jin. 2013. National Assessment of Energy Storage for Grid Balancing and Arbitrage, Phase II, Volume 2: Cost and Performance Characterization. PNNL-21388. Pacific Northwest National Laboratory (PNNL), Richland, WA (US). Accessed May 25, 2016. <http://www.pnl.gov/publications/abstracts.asp?report=415454>.
- [251] 2011. Quantifying the Value of Hydropower in the Electric Grid: Plant Cost Elements. Electric Power Research Institute. Technical Report 1023140. Palo Alto, CA (US). Accessed April 28, 2016, <http://www.epri.com/abstracts/Pages/ProductAbstract.aspx?ProductId=00000000001023140>.
- [252] Ela, E.; B. Kirby; A. Botterud; C. Milostan; I. Krad; and V. Koritarov. 2013. The Role of Pumped Storage Hydro Resources in Electricity Markets and System Operation. NREL/CP-5500-58655. National Renewable Energy Laboratory (NREL), Denver, CO (US). Accessed May 25, 2016, [http://primo-pmtna01.hosted.exlibrisgroup.com/Pubs:PUBS:NREL\\_HORIZON81213](http://primo-pmtna01.hosted.exlibrisgroup.com/Pubs:PUBS:NREL_HORIZON81213).
- [253] Jobs and Economic Development Impact (JEDI) Models. National Renewable Energy Laboratory. Accessed May 25, 2016. <http://www.nrel.gov/analysis/jedi/>.
- [254] U.S. Department of Energy. Prepared by Navigant Consulting, Inc. DOE/EE-1400. Forthcoming (2016). "United States Hydropower Workforce Assessment and Future Scenarios".
- [255] U.S. Department of Energy. Prepared by Navigant Consulting, Inc. DOE/EE-1400. Forthcoming (2016). "United States Hydropower Workforce Assessment and Future Scenarios".
- [257] U.S. Census Bureau. 2014. American Community Survey. Accessed May 25, 2016. <https://www.census.gov/programs-surveys/acs/>.
- [258] "Economic Development Programs," New York Power Authority, accessed May 2, 2016, <http://www.nypa.gov/services/economicdev/economic.htm>.
- [259] Glanz, J. 2012. "Data Barns in a Farm Town, Gobbling Power and Flexing Muscle." *New York Times*, September 23. Accessed May 2, 2016, <http://www.nytimes.com/2012/09/24/technology/data-centers-in-rural-washington-state-gobble-power.html?page-wanted=all&r=0>.
- [260] "Energy needed to produce aluminum," August 16, 2012. Energy Information Administration, Today in Energy. Accessed May 25, 2016. <http://www.eia.gov/todayinenergy/detail.cfm?id=7570>.
- [261] "Boulder Canyon Project - Hoover Dam." Bureau of Reclamation. Last modified February 1, 2012. Accessed May 25, 2016, [http://www.usbr.gov/projects/Project.jsp?proj\\_Name=Boulder+Canyon+Project+-+Hoover+Dam](http://www.usbr.gov/projects/Project.jsp?proj_Name=Boulder+Canyon+Project+-+Hoover+Dam).

- [262] Simonds, Wm. J. 2009. Hoover Dam: The Boulder Canyon Project. U.S. Bureau of Reclamation. Project History; originally completed in 1995. Reformatted, reedited, and reprinted by Brit Storey in 2009. Accessed May 25, 2016. [http://www.usbr.gov/projects/Project.jsp?proj\\_Name=Boulder+Canyon+Project++Hoover+Dam](http://www.usbr.gov/projects/Project.jsp?proj_Name=Boulder+Canyon+Project++Hoover+Dam).
- [263] McMahon, G.; W. Wade; B. Roach; M. Farmer; and A. Fredrich. 2004. Lake Lanier National Economic Development Update: Evaluation of Water Supply, Hydropower and Recreation Benefits. Atlanta Regional Commission, Cobb County-Marietta Water Authority. Accessed May 2, 2016. <http://www.1071coalition.org/downloads/LL%20Econ%20Dev%20Study%202004.pdf>.
- [264] Garrison Dam/Lake Sakakawea Project North Dakota Surplus Water Report. 2010. U.S. Army Corps of Engineers. Accessed May 25, 2016. <http://denr.sd.gov/mr/PublicDraftSakakaweaSurplusWaterReport.pdf>.
- [265] The Economic Benefits of Multipurpose Reservoirs in the United States. 2015. Oak Ridge National Laboratory (ORNL), Oak Ridge, TN (US). Accessed May 2, 2016. [http://www.ieahydro.org/media/65043df2/HYDRO2015MultipurposeReservoirs\\_Paper\\_14August2015.pdf](http://www.ieahydro.org/media/65043df2/HYDRO2015MultipurposeReservoirs_Paper_14August2015.pdf).
- [266] U.S. Department of the Interior Economic Report FY 2013 Draft. 2014. U.S. Department of the Interior. Accessed May 25, 2016. <http://www.iwr.usace.army.mil/Media/NewsStories/tabid/11418/Article/481131/report-measures-value-to-the-nation-of-us-army-corps-of-engineers-civil-works-p.aspx>.
- [267] U.S. Department of the Interior Economic Report FY 2013 Draft. 2014. U.S. Department of the Interior. Accessed May 25, 2016. [https://www.doi.gov/ppa/economic\\_analysis/fy-2013-economic-report](https://www.doi.gov/ppa/economic_analysis/fy-2013-economic-report).
- [268] Value to the Nation of the U.S. Army Corps of Engineers Civil Works Program. 2013. Institute for Water Resources, accessed May 2, 2016, [http://www.iwr.usace.army.mil/Portals/70/docs/iwrreports/2013-R-09\\_vtn.pdf](http://www.iwr.usace.army.mil/Portals/70/docs/iwrreports/2013-R-09_vtn.pdf).
- [269] Russell, C. 1970. Industrial Water Use. National Water Commission.
- [270] Loomis, J., "Quantifying recreation use values from removing dams and restoring free-flowing rivers: A contingent behavior travel cost demand model for the Lower Snake River," *Water Resources Research*, 38 (2002): 1-8. Accessed May 25, 2016. DOI: <http://dx.doi.org/10.1029/2000WR000136>.
- [271] Debnath, D.; T. Boyer; A. Stoecker; and L. Sanders, "Nonlinear reservoir optimization model with stochastic inflows: Case study of Lake Tenkiller," *Journal of Water Resources Planning and Management* 141 (2014), accessed May 25, 2016. DOI: [http://dx.doi.org/10.1061/\(ASCE\)WR.1943-5452.0000409](http://dx.doi.org/10.1061/(ASCE)WR.1943-5452.0000409).
- [272] Ward, F. and T. Lynch, "Integrated River Basin Optimization: Modeling Economic and Hydrologic Interdependence," *Water Resources Bulletin*, 32 (1996): 1127-1138. Accessed May 25, 2016. <https://www.sciencebase.gov/catalog/item/505397e0e4b097cd4fce63bf>.
- [273] Hanson, T.; L. Hatch; and H. Clonts, "Reservoir water level impacts on recreation, property, and nonuser values," *Journal of the American Water Resources Association*, 38 (2002): 1007-1018. DOI: <http://dx.doi.org/10.1111/j.1752-1688.2002.tb05541.x>.
- [274] B. Hadjerioua, K. D. Patrick, S. Kao, Y. Wei, S. K. SanthanaVannan, G. Palanisamy, H A. Shanfield III, M.J. Sale, R. Devarakonda, and B. T. Smith, "National Hydropower Asset Assessment Project" Oak Ridge National Laboratory (ORNL), World Environmental & Water Resources Congress, Palm Springs, California, May 2011.

## A New Chapter for America's <sup>1<sup>st</sup></sup> Renewable Electricity Source

This first-of-its-kind analysis builds on the historical importance of hydropower and establishes a roadmap to usher in a new era of growth in sustainable domestic hydropower.



U.S. DEPARTMENT OF  
**ENERGY**

DOE/GO-102016-4869 • July 2016

Cover photos from iStock 55486650, 83494953, 28045480, 1946803