

Wind Power – Part II

John C. Bean

Outline

Offshore Wind Power: The potential rewards / The unique challenges

Wind Power economics: LCOE

Wind Power Return on Energy Invested: EROI

Integrating wind power into the Grid:

- Power conversion, transmission and storage

- The looming threat of Grid instability

 - Wind's role in crashing Southern Australia's Grid?

The broader impacts of Wind Power:

- Onshore Wind Power's bird & bat Kills

- Offshore Wind Power's effect upon sea life

- Noise

- NIMBY

(Written / Revised: August 2022)

Wind Power – Part II

Wind Power - Part I ([pptx](#) / [pdf](#) / [key](#)) I focused narrowly upon wind and wind turbines

In this note set I'll explore Wind Power more broadly, including:

Its impact upon our Grid, our economy, our society, and our biosphere

This will include consideration of Wind Power's:

Monetary cost (LCOE), its energy return on energy invested (EROI),

its connection to the Grid (including possible de-stabilizing effects),

its impact on neighboring humans and animals . . .

But I will open this note set by discussing Offshore Wind Power,

which could have been covered in Part I, but actually fits well in Part II

because its impacts are very different, and often more favorable

Concerning wind, the big takeaways from Part I were:

Wind's power increases as its velocity cubed:

SLIGHTLY faster winds => VASTLY greater wind power

And where are the surest places to find faster winds?

Higher off the ground

AND

Off our northern coasts:

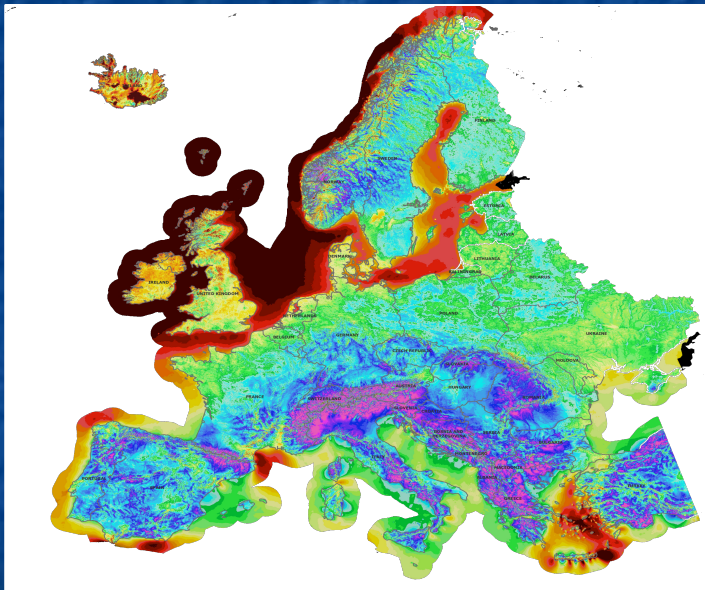

Fastest = Brown/Red

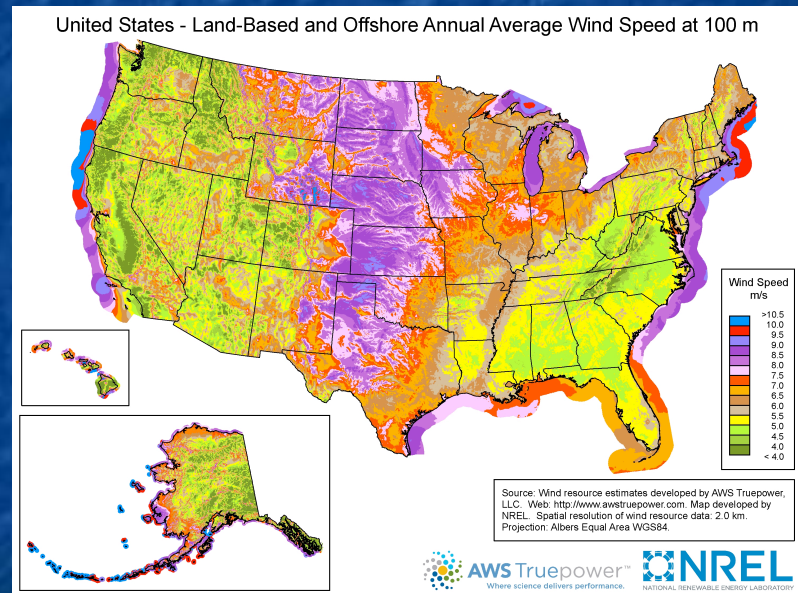

Fastest = Blue / Red:

Wind Power - Part I ([pptx](#) / [pdf](#) / [key](#)):

Left: <https://aws-dewi.ul.com/assets/Wind-Resource-Map-EUROPE-11x17.pdf>

Right: www.nrel.gov/gis/wind.html

Offshore Wind Power

Construction of offshore wind turbines is a **lot** more difficult:

This U.S. government graphic predicted that for turbines in water of depths:

≤ 30 meters: Fixed tubular bases could be still driven into the seabed

30-60 meters: Complex underwater towers would instead be required

> 60 meters: Floating semi-submerged platforms would become necessary

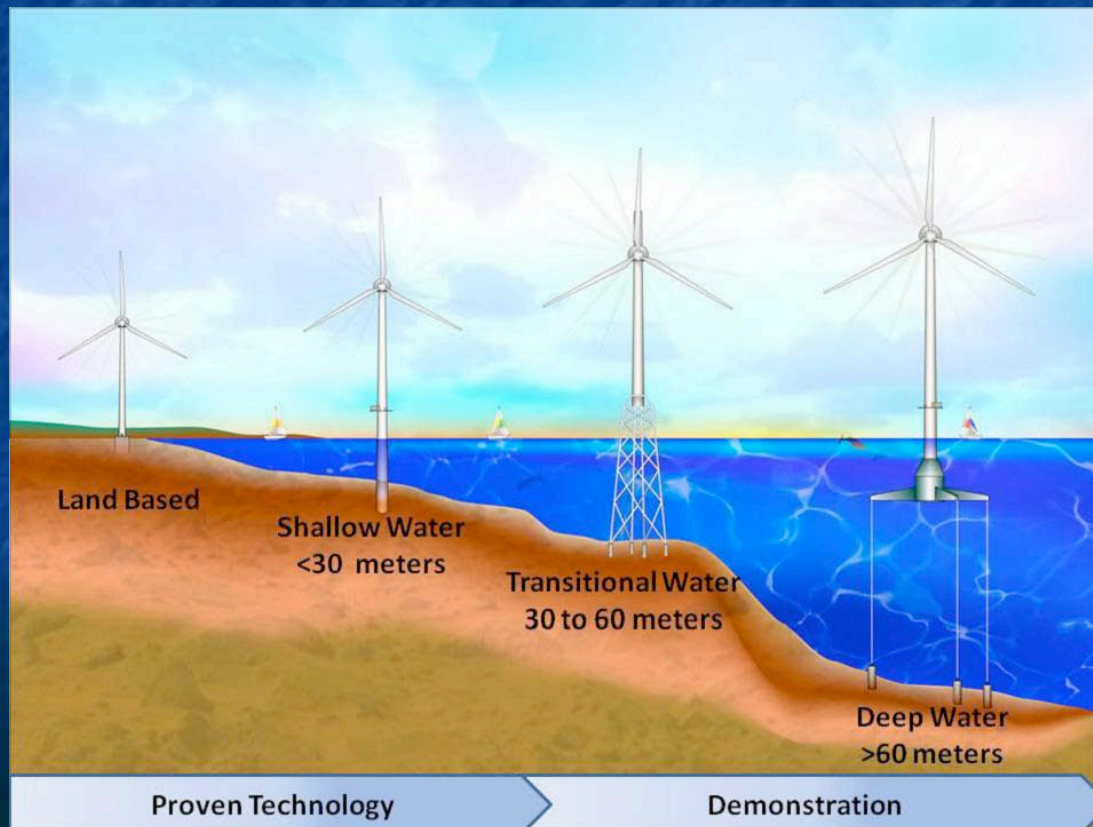

<http://www.boem.gov/renewable-energy-program/renewable-energy-guide/offshore-wind-energy.aspx>

The DOE's "Wind Vision" then identified three classes of floating turbines: 1

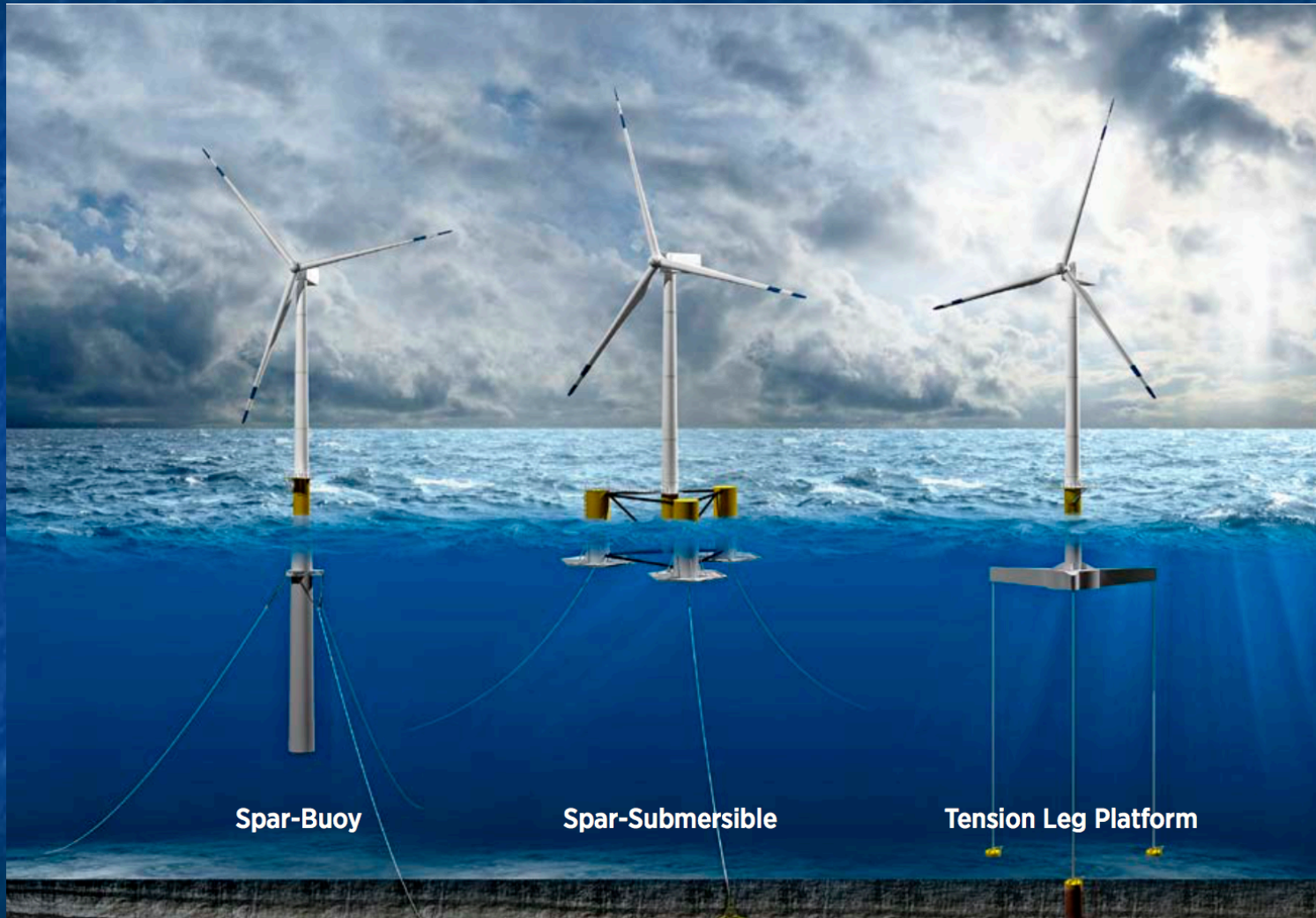

But even shallow technologies were thought to be hopelessly expensive:

Early in this decade the U.S. Energy Information Administration (EIA)

estimated the cost of wind power above even < 30 meter deep seas

as almost **three times more expensive than onshore wind** ¹

Further, residents of U.S. resort islands off the shores of New England

objected strenuously (and effectively) about offshore turbines' visual impact

Finally, even if the cost of shallow fixed based turbines **could** be reduced,

30 meters (98 feet) doesn't sound very deep, suggesting that offshore turbines

could only be built in a very narrow band very close to U.S. shores

Off our eastern shores, at least, that last objection turns out to be wrong:

30 meters depth takes you a surprisingly long way off some U.S. shores:

The lighter blue band in these figures is for depths up to 30 meters

Along much of the U.S. east coast, that band is nearly 50 miles wide ¹

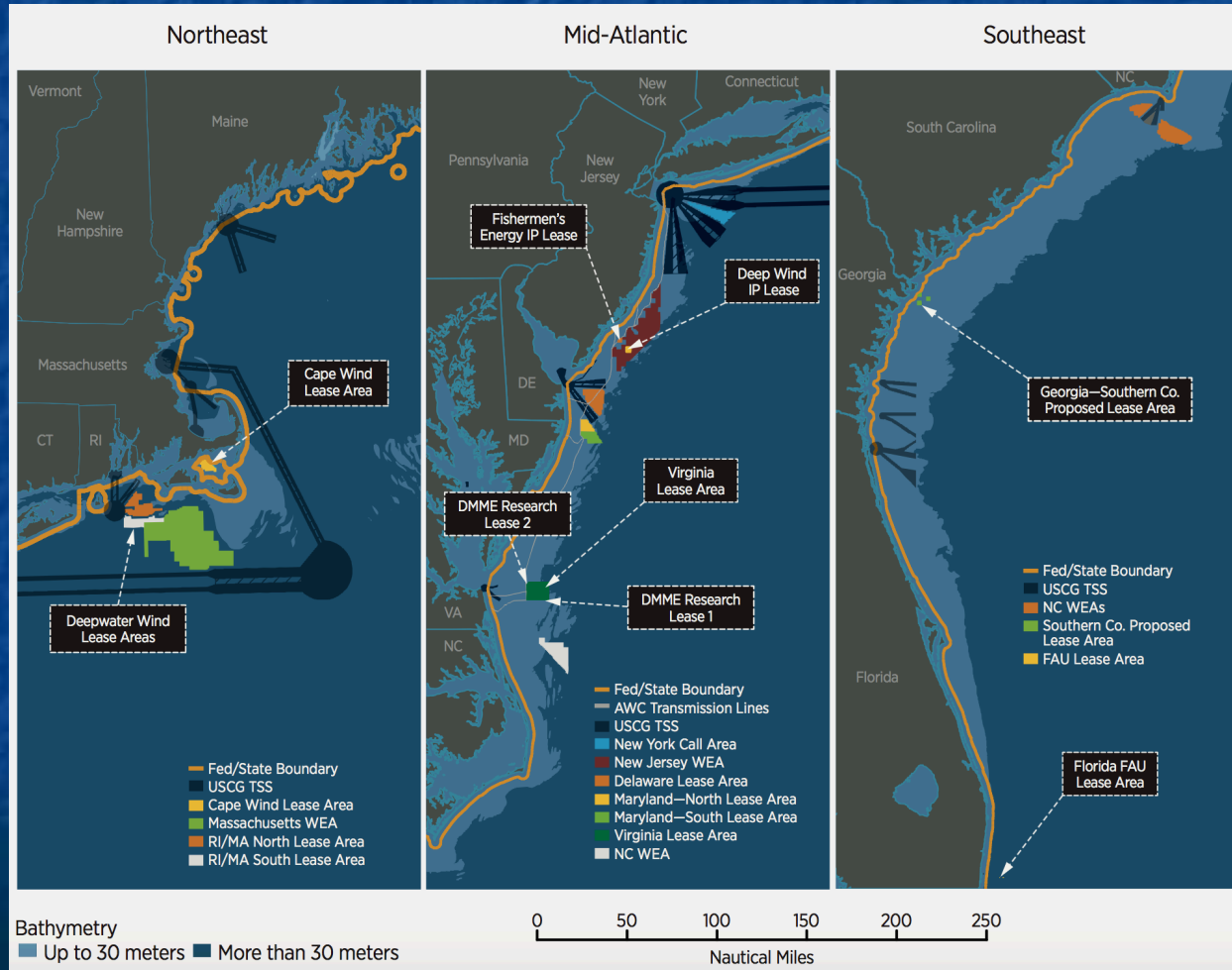

1) p 75. Wind Vision Report – US DOE: <https://www.energy.gov/eere/wind/wind-vision>

But what about the 3X higher cost of even 30 meter deep turbines?

That EIA cost analysis, compounded by concerns about ruining resort island views,
led the U.S. to essentially ignore development of offshore wind power

In contrast, Northern Europeans (including British, Danes and Germans)
lack many of our more affordable energy alternatives,

but their adjacent North & Irish Seas **are** unusually shallow

And as a result, **they** aggressively pursued development of offshore wind power

**Which has produced some very interesting,
and possibly game-changing, developments:**

One development challenges the limits of fixed base shallow water turbines:

Ships are now built for the **sole purpose** of installing offshore wind turbines

This one has six legs that actually lift it above the ocean surface

Turbine bases are then pile-driven into ocean bottom in as little as one day

Which should sharply reduce offshore wind farm construction costs

Further, this ship can drive in foundations beneath water up to **50 meters deep**

Versus the earlier U.S. government figure's claimed limit of "< 30 meters"



This ship was the subject of a Smithsonian Channel documentary:

From which a two minute clip was posted on the web:



YouTube link: https://www.youtube.com/watch?v=QltAyg_R2go

(I have also cached a copy of that clip on this note set's [Resources Webpage](#))

How far out would this ship's 50 meter depth range take us?

Here I've sketched in lines **30** and 60 miles off the Virginia coast

The faint black line between them calls out 50 meter depth (blue label)

50 meter depth takes us almost to the edge of the continental shelf

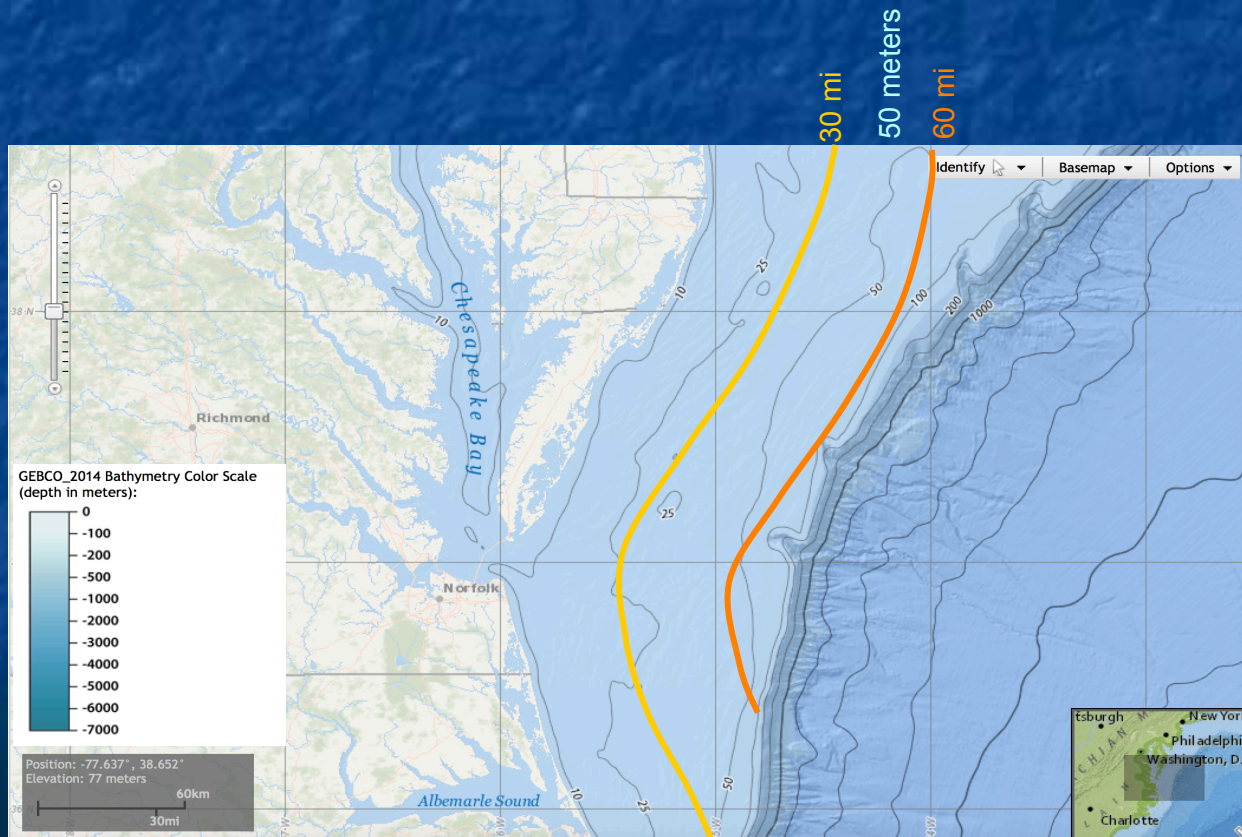

Anticipating my later discussion of NIMBY ("Not in MY Backyard!"):

To disappear below the horizon, how far offshore would a wind turbine have to be?

A modern 6 MW wind turbine rises to about 175 meters ¹ = H

The earth's radius is 6371 km (3959 miles) = **R**, calling on Pythagoras:

$$X^2 + R^2 = (R + H)^2 = R^2 + H^2 + 2RH$$

$$\text{Or } X^2 = H^2 + 2RH$$

But $R \gg H$, making $2RH \gg H^2$, so the equation becomes:

$$X^2 \sim 2RH \quad \text{Or} \quad X \sim \sqrt{(2RH)}$$

Thus, for $H = 175$ m and $R = 6.4 \times 10^6$ m, we get:

$$X = 47 \text{ kilometers} = 28 \text{ miles}$$

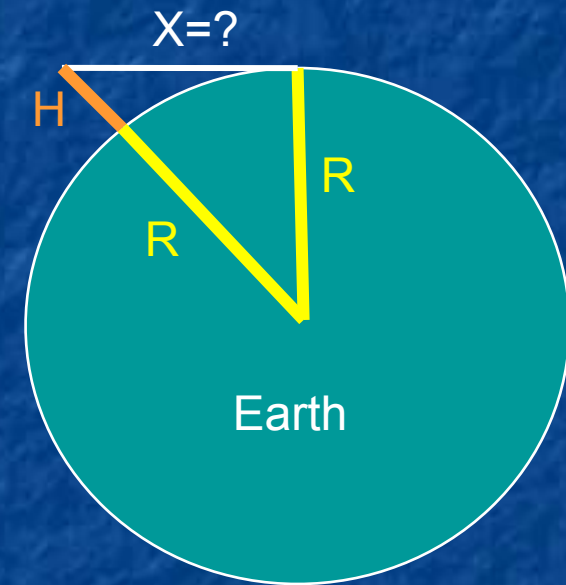

From shore the entire turbine is below the horizon if it's > 30 miles out

MUCH of it is below horizon 15 miles out => ³/₄ of VA continental shelf

1) Per the data on Siemens 6MW turbines given on the immediately following slides

*And the 1st ever **Floating Wind Farm** may render depth limits obsolete:*

Developed by a company that's built & maintained offshore oil platforms for 40 years

Completed in the fall of 2017, twenty-five kilometers off Scotland's eastern coast:

Five 6 MW, 154 meter diameter turbines,

towering 175 meters above sea level,

with an additional 78 meters of buoyant "spar buoy" below sea level,

attached to three seabed "suction anchors" (and electrical cables) ¹

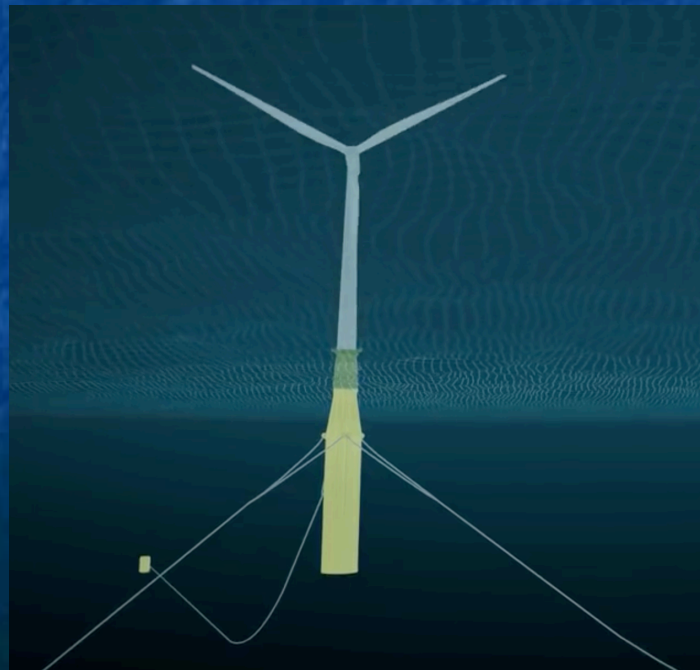

1) From "Hywind Scotland" brochure:
<https://www.equinor.com/content/dam/statoil/documents/newsroom-additional-documents/news-attachments/brochure-hywind-a4.pdf>

Construction of the floating bases:

Bases were fabricated in Spain, then floated into a Norwegian assembly harbor:



In that harbor, 5000 tonnes of iron ore was poured into each base, tilting it upright:



*Pictures and information from:
<https://www.youtube.com/watch?v=PUlfvXalSvc&vl=en>*

Assembly of the floating turbines:

Siemens SWT-6.0-154 turbines ¹ were assembled onshore at water's edge, with a floating crane barge standing by:



Moving out into the assembly harbor, that barge mated turbines with floating bases:



Pictures and information from:
<https://www.youtube.com/watch?v=PUIfvXaISvc&vl=en>

1) <https://www.4coffshore.com/windfarms/contracts-on-hywind-scotland-pilot-park-uk76.html>

Transport to wind farm site off Scotland:

111 tonne Scottish made "suction anchors" were loaded onto a transport vessel, then lowered to sea bottom 25 km offshore at wind farm site:



Floating turbines were towed from Norway to that farm & connected to those anchors:



*Pictures and information from:
<https://www.youtube.com/watch?v=PUlfvXaISvc&vl=en>*

Statoil's video about their "Hywind-Scotland" - 1st ever floating Wind Farm:

= The source of most of the preceding images and information



YouTube link: <https://www.youtube.com/watch?v=PUIfvXaISvc&vl=en>

(I have also cached a copy of that video on this note set's [Resources Webpage](#))

Hywind-Scotland has operated exceptionally well in its first year:

The wind industry press reports that over its first three months of operation: ¹

It produced average power output at 65% of its capacity

(which should mean average power of $5 \times 6 \text{ MW} \times 0.65 = 19.5 \text{ MW}$)

Further, that 65% level included brushes with two major storms:

October's hurricane Ophelia, which produced 125 km/hr winds at the wind farm

(which would then/there make it a Category 1 hurricane) ²

And December's Caroline, which produced gusts to 160 km

(which, had they been sustained, would qualify as Category 2) ²

Hywind's 65% of capacity output was compared to fixed (shallow water) wind farms

which the article claimed typically produce average power at 45-60% capacity

(consistent with 2018 EIA number of 45% for offshore wind farms) ³

1) <https://www.offshorewind.biz/2018/02/15/worlds-first-floating-wind-farm-outdelivers/>

2) https://en.wikipedia.org/wiki/Saffir%E2%80%93Simpson_scale

3) See my web note set on: **Power Plant Economics – Analysis Techniques & Data** ([pptx](#) / [pdf](#) / [key](#))

But what about NIMBY? Per my earlier calculation of view horizons:

That **Floating Wind Farm** would be completely below the horizon (thus invisible) if it were situated more than 47 km (28 miles) offshore

But what if it weren't that far offshore (as the Hywind Scottish wind farm is not!):

How objectionable would its appearance still be?

I decided to simulate an offshore turbine's appearance from onshore:

I found a photo with a beach view off the "Jersey Shore" of the U.S.

It appears to have ~30° field of view (a slightly magnified telephoto image)

(But similar to what you'd notice if you stared directly offshore)

I calculated how big a 175 m tall wind turbine (+ 330 m cruise ship)

would appear in such a beach view - for different distances off shore: ¹

1) My spreadsheet calculations are downloadable from this note set's [Resources Webpage](#)

Simulated views of offshore wind turbine + cruise ship:

Wind turbine: 175 m (574') tall (Hywind-Scotland / Siemens 6 MW turbine)

Cruise ship: 335 m (1100') long x 63 m (227') tall (large modern cruise ship)

Use PgDn Key



Based on my estimate that this photo had ~ 30° wide field of view, and was shot at ~ 5 m above sea level

All of which has led the U.S. to reconsider offshore wind power:

In late 2016 the **1st U.S. offshore wind farm** became operational off Block Island ¹

Five 6MW fixed base turbines

180 meters tall

Located 6.1 km offshore

Claimed to be able to survive a Category 3 hurricane



Other farms are proposed (some with partial funding) off the shores of: ^{2, 3}

Massachusetts, Rhode Island, New York, New Jersey,

Maryland, Virginia & North Carolina

With the more ambitious projects targeting wind farm capacities of 400-1500 MW

Photo: <http://www.blockislandreservations.com/activities/tour-block-islands-wind-farm>

1) https://en.wikipedia.org/wiki/Block_Island_Wind_Farm

2) https://en.wikipedia.org/wiki/List_of_offshore_wind_farms_in_the_United_States

3) <https://e360.yale.edu/features/after-an-uncertain-start-u-s-offshore-wind-is-powering-up>

And offshore wind is **finally** plausible off our western coasts:

There, ocean depths plunge due to **plate tectonics**

For instance, in Monterey Bay
**the 50 meter depth contour
is typically only 3-7 km offshore**

vs. 75 to 100 km offshore on our east coast!

Fixed-base wind turbines would thus
have to be **extremely** close to shore

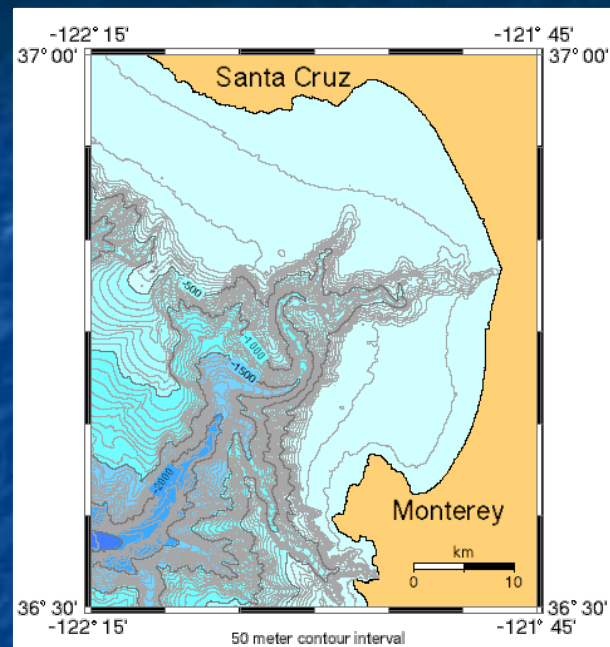

<https://walrus.wr.usgs.gov/monterey/mbbms/indexmap.html>

But the Hywind-Scotland type floating wind farms remove that restriction

And floating wind farms are thus being proposed well off western shores, including: 1

A 60-100 turbine, up to 1000 MW total capacity, floating wind farm

53 kilometers (33 miles) off Morro Bay in central California 1, 2

And a smaller up to 100-150 MW floating farm off Eureka in northern California 3

1) <https://www.technologyreview.com/s/608128/floating-wind-plan-could-finally-crack-californias-offshore-market/>

2) https://www.marinelog.com/index.php?option=com_k2&view=item&id=28822:northern-california-could-be-home-to-first-us-floating-wind-farm&Itemid=257

3) <https://www.maritime-executive.com/article/new-offshore-wind-project-planned-for-california#gs.JcOLM6U>

BREAKING NEWS:

(Relevant news articles I've not yet fully researched and/or verified)

"Dominion Energy Plans Major Offshore Wind Farm off Virginia Beach"

Washington Post - 9 September 2019

"Would be the largest of its kind in the country"

"220 giant wind turbines on a patch of ocean 27 miles off the coast"

"Would generate 2,600 megawatts of electricity by 2026"

"Estimated to cost \$7.8 billion"

That WOULD be a BIG deal

It would in be the world's LARGEST offshore wind farm (by some margin): ¹

Biggest existing: "Walney Extension" UK - 659 Megawatts

Biggest planned: "Homsea Project 1" UK (completion 2020) - 1218 Megawatts

Might be 1st "green" (wind/solar) plant EVER equaling size of carbon & nuclear plants

1) Wikipedia's "List of Offshore Wind Farms" (and other sources)

***Wind Power Economics
&
Energy Return on Energy Invested***

But can we afford Wind Power?

That can be a complex question. It requires comparisons with other technologies
It may also be that power plant cost is not the major concern, as when the cost
of power is instead dominated by fuel or operational & maintenance expenses
Or the cost of power may be inflated by financing expenses (interest/bond payments)
as can be the case for technologies with shorter operational lifetimes:

e.g., solar & **wind** (20 years) vs. nuclear (40 years) vs. hydro (100 years)

And those financing costs may escalate for technologies considered high risk,
including nuclear (more because of construction defaults than rare accidents)
or for very young & unproven technologies (e.g., **floating wind power**)

Hence my whole note set on: **Power Plant Economics** ([pptx](#) / [pdf](#) / [key](#))

explaining the **Levelized Cost of Energy (LCOE)** for alternate technologies

Nevertheless, here is a quick overview of Wind Power economics:

(Which really should be followed by study of my full **Power Plant Economics** ([pptx](#) / [pdf](#) / [key](#)) note set!)

In principle, **Levelized Cost of Energy (LCOE)** takes into account ALL costs:

Capital, Construction, Fuel, Operation & Maintenance, and Decommissioning . . .

as well as the full financing of all of the above, over the full plant life cycle

It should thus be equal to the power company's breakeven charge for power

LCOEs are stated in terms of **\$/MW-h**, now typically **\$50 - \$200 / MW-h**

But we are **charged** for power in **cents/kW-h**, typically **10 - 20 cents / kW-h**

$$1 \text{ } \$/\text{MW-h} = 100 \text{ cents} / (1000 \text{ kW})\text{-h} = 0.1 \text{ cents} / \text{kW-h}$$

$$\text{Thus: } \$50 - \$200 / \text{MW-h} = 5 - 20 \text{ cents/kW-h}$$

Thus, to make a profit selling power to us at 10 - 20 cents/kW-h,

power companies need production LCOE's of \$50 - \$100 / MW-h

We tend to use LCOEs from the U.S. Energy Information Administration

Each year the EIA estimates LCOEs for a dozen or so types of U.S. power

**But that estimation is done by economists who, like social scientists,
may not follow (or fully appreciate) ongoing technical development**

I (and many others) have come to believe that this can lead to significant errors

Indeed, in the remainder of this note set I'll provide multiple examples of how
re-analysis of some study data has led me to very different conclusions

For the EIA, problems often stem from an over-reliance on U.S. experience:

If we don't now use a technology (e.g., **floating wind power**) it may be omitted

If we've only one, possibly non state-of-the-art example (e.g., **Block Island**)

it may become the sole basis for estimating cost of **any** plant of this type

If we now employ many generations of a technology (e.g., **onshore wind**),

these are just averaged together ignoring their often major cost differences

Is there an alternative (more expert) source of U.S. LCOE data?

Yes

Lazard.com analyzes the U.S. energy market **for** U.S. energy companies

This it does (presumably for a substantial fee) about once every two years

They do not release their full reports

But they do release public summaries (typically of 22 pages)

Both recent EIA & Lazard data are in **Power Plant Economics** ([pptx](#) / [pdf](#) / [key](#))

This is its summary slide of 2018 EIA and 2017 Lazard data:

LCOE's: EIA 2018 vs. Lazard 2017

	EIA	Lazard
Sequestered IGCC Coal	119.1	143
Natural Gas CC (CCGT)	50.1	42-78
Natural Gas Peaking (OCGT)	85.1	156-210
Hydroelectric	61.7	
Nuclear	92.6	112-183
Biomass - no subsidy (subsidized)	95.3	55-114 (40-112)
Geothermal - no subsidy (subsidized)	44.6 (41.6)	77-117 (64-116)
Wind Onshore - no subsidy (subsidized)	59.1 (48)	30-60 (14-52)
Wind Offshore - no subsidy (subsidized)	138.0 (117.1)	113
Solar PV	63.2 (49.9)	
Si crystalline PV – utility - no subsidy (subsidized)		46-53 (37-42)
Thin Film PV – utility - no subsidy (subsidized)		43-48 (35-48)
Solar Thermal w/o Storage - no subsidy (subsidized)		237
Solar Thermal w/ Storage - no subsidy (subsidized)	165.1? (126.6)?	98-181 (79-140)

Things to note on that slide:

Onshore Wind Power's LCOE is 30-60 \$/MW-h

Even acknowledging the above range in LCOE estimates, it is clear that:

Onshore Wind Power is now decidedly cheaper than:

Sequestered coal, Natural gas (peaking / OCGT), Nuclear and Biomass

Its present cost is roughly comparable to:

Natural gas (CCGT), Geothermal, Hydroelectric and utility-scale Solar

But it remains significantly more expensive than:

No other U.S. power source

Which is why more than half of new U.S. power comes from onshore wind!

Things to note on that slide (cont'd):

Offshore Wind Power's LCOE is 113-138 \$/MW-h

Given that we have ONLY one offshore wind farm (Block Island)

that LOCE likely ¹ represents **fixed base / shallow water 6 MW turbines**

It's likely not for **fixed base offshore 12 MW turbines** GE plans to install by 2020,

despite EIA reports being for power sources "coming online five years from now"

It almost certainly does not represent **floating wind turbines** (of any size)

After all, there is only one barely-year-old floating wind farm in the whole world!

And while the Statoil / Hywind-Scotland video claims that costs have already

fallen significantly from those of their earlier, smaller, single prototype

They concede that Hywind-Scotland will need subsidization for the time being

Elsewhere, they state a 2030 goal of LCOE = 40-60 Euro / MW-h (~ 50-75\$) ²

1) The EIA makes it surprisingly difficult to identify **exactly which technologies** their LCOE estimates are based upon!

2) <https://www.equinor.com/en/what-we-do/hywind-where-the-wind-takes-us/our-ambitions-for-hywind.html>

But LCOE's evaluate only today's monetary costs

What about longer-term, bigger-picture environmental costs?

One way of evaluating this is to evaluate an energy technology's:

Energy Return on Invested energy (EROI)

= Total lifetime energy produced by a power plant or power source

divided by all of energy EVER put into that power plant/source

for its materials, construction, operation and ultimate decommissioning

Which implicitly assumes that for two technologies producing an amount of energy X,

the one requiring a lower net energy input to do so

stands an excellent chance of having a lower environmental impact

Like LCOEs, EROIs require a lot of input and are thus very difficult to calculate

And those calculations are once again done by economists & social scientists

who may not fully appreciate ongoing technological development

My full exploration of EROI thus again required a full note set: ¹

(Which, again, you really should eventually read in its entirety!)

But here are the highlights of that note set's discussion of Wind Power:

The seminal technology-spanning study of EROI was by Murphy & Hall in 2010

For Wind Power they drew on data from a then new paper by Kubiszewski et al.

They estimated a single EROI that did not differentiate between wind technologies

Murphy & Hall (2010): **Wind EROI = 18**

Which, rounded up to 20 is still the most commonly cited value

But there was an earlier paper by White & Kulcinski in 1998, instead suggesting:

Onshore wind EROI = 34 vs. **Offshore wind EROI = 18**

But those data were even then so old as to be considered suspect

Which was perhaps why they were seemingly ignored by Murphy & Hall

1) My note set: [Lifetime Energy Output vs. Lifetime Energy Investment](#) ([pptx](#) / [pdf](#) / [key](#))

It also included a correlation of EROI with wind turbine power rating:

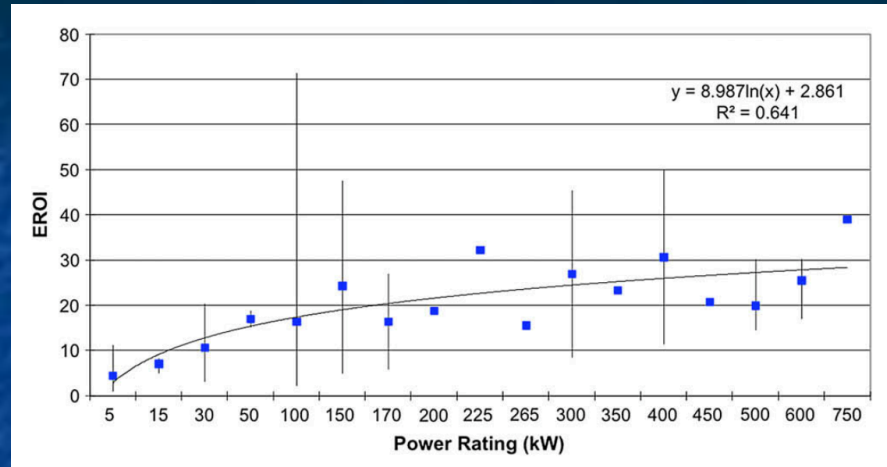

Small turbines at left => **Wind EROI's of 5-20**

Almost 1 MW turbines at right => **Wind EROI's of 30-40**

But these economists & social scientists failed to appreciate the significance

This correlation with turbine power was far more than a curiosity

Given the ongoing technological evolution of wind turbines,

It was effectively a correlation of EROI with the wind turbine's age:

WE know why and how wind turbine power has been increasing:

Wind **speed** increases with the altitude above the ground

Wind **power** grows even more quickly (as wind speed cubed)

Making taller turbines much more powerful

But taller turbines **also** accommodate larger blades

Which, putting this all together, makes taller turbines **vastly** more powerful

For **at least twenty** years, this has driven the evolution of Wind Power technology:



Missing this, EROI researchers just averaged wind turbine results together

Which gave the newest turbines (then being installed at wind farms)

far less weight than that of much smaller turbines installed 5-20 years earlier

In other words, these EROI studies mixed apples & oranges:

Vintage 1985-1995 ≤ 0.2 MW
wind turbines: **EROI = 5-20**



Vintage 1995-2005 ≤ 1 MW
wind turbines: **EROI = 30-40**



Naive averaging thereby yielded the studies' stated **Wind Power EROI = 18-20**

Despite then current 2010 technology having EROI of ~ 40

Further, the 18-20 figure is **still** widely accepted & cited because there have yet to be
any widely acknowledged follow-on **studies** (!!!)

Despite modern turbines now growing to **6 MW**

Leading me (and others) to suspect that those
modern turbines likely have **EROI $\gg 40$**



My bottom line reevaluation of ALL energy EROI's (from my EROI note set): ¹

Technology

EROI

Heat from:

Conventional oil	16
Ethanol from sugarcane	9
Biodiesel from soy	5.5
Tar Sands	5
Heavy oil from California	4
Ethanol from corn	1.4

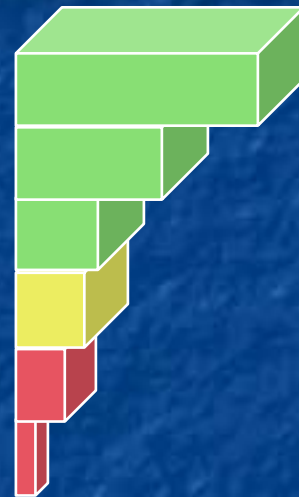

Likely now lower for fossil fuels
and/or overstated for biofuels.
But insufficient new data
to support strong revisions

Electricity from:

Hydroelectric Dams	40+
Wind	~ 40
Coal (CC)	2.5-5
Natural Gas (CCGT)	3.5-5
Solar PV	9, 12, 15, 35
Nuclear	35-40

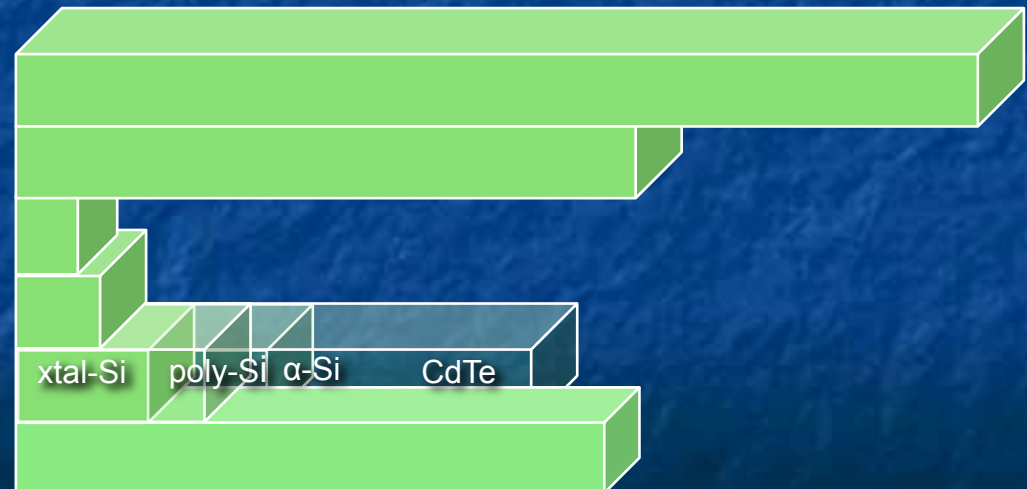

1) Lifetime Energy Output vs. Lifetime Energy Investment ([pptx](#) / [pdf](#) / [key](#))

Integration of Wind Power into the Grid

Integration of Wind Power into the Grid:

My **Magnetic Induction** ([pptx](#) / [pdf](#) / [key](#)) note set explains why varying magnetic fields are essential for the operation of motors, generators and transformers

Power systems were thus designed to deliver oscillating (AC) electrical power, which almost always originates from **something** turning the shaft of a generator

That "something" can be a combustion turbine, or a steam, water or wind turbine

The speed of which determines HOW FAST the electrical power oscillates

In the U.S. that oscillation is held at **60 ± 0.067 Hz** (cycles per second) ¹

To control a turbine's speed, **we control** its input flow of fuel, steam or water

But **WE CANNOT CONTROL** the flow of wind into wind turbines

A simple wind turbine thus tends to produce AC power out of step with the GRID

Yielding, when connected to the Grid: Sparks, heat, fire, smoke (explosions) . . .

1) See my **Generic Power Plant & Grid** ([pptx](#) / [pdf](#) / [key](#)) note set

*Grid integration thus requires **not-so-simple** wind turbines*

While wind speeds cannot be controlled, we can control turbine blade pitch:

By using the simple gear-driven "pitch control" mechanism shown here in the hub of a smaller aircraft propeller:

<http://www.explainthatstuff.com/how-propellers-work.html>



Larger versions of this mechanism were built into the hubs of early wind turbines

The blade pitch was then continuously adjusted such that, in variable winds, turbines would still rotate at the speed required to produce 60 Hz power

This allowed connection of early turbines to the Grid (w/o sparks, heat, fires . . .)

But speed control required near-continuous adjustment of blade pitch, which tended to wear out the geared mechanism above,

thereby shortening the wind turbine's operational lifetime

*Modern wind turbines thus use an **even more complex scheme**:*

Blade pitch is changed **only** to help start and stop the turbine's rotation

But during normal rotation, the pitch is fixed (at some optimized value)

This minimizes wear and tear on the blade pitch control mechanism,
significantly extending the lifetime of that turbine

But with fixed pitch, the turbine's rotation speed changes with wind speed

That variable rotation is sent (via a geared transmission) to an AC generator

Driven at variable speed, that AC generator produces AC power

with variable frequency, phase & voltage which is **NOT Grid compatible**

But via new semiconductor device technology, that variable/unregulated AC power

is then **converted to DC** (non-oscillating) electrical power

Which then, using other new semiconductor devices,

is **converted back into AC**, but synchronized AC which **IS Grid compatible**

The resulting circuit diagram/circuit looks something like this:

Where the green AC/DC and DC/AC boxes are the semiconductor-based converters ¹

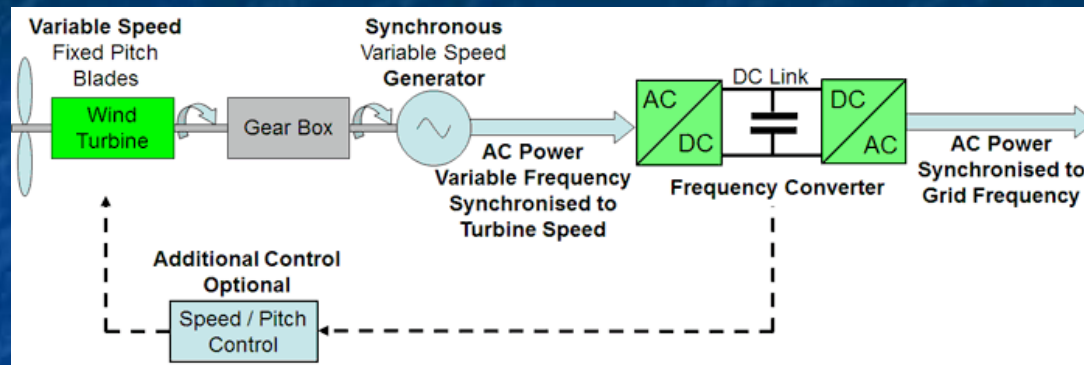

Not shown here is a critical connection **from the Grid** into the frequency converter

That connection tells the converter the Grid's precise frequency and phase

Allowing the converter to synchronize its wind-driven AC output **to the Grid**

Note: Grid synchronization circuits similar to this played a role in the

2016 South Australian Grid blackout (as will be described shortly)

Semiconductor circuits also convert **solar cell's** DC output into Grid compatible AC

As detailed in (for wind **and** solar): **Renewable Distributed Grid** ([pptx](#) / [pdf](#) / [key](#))

1) Figure & details are from an *excellent wind power tutorial* in MPOWERUK.COM's "Electopaedia"
https://www.mpoweruk.com/wind_power.htm

But synchronization is not the only Wind Power integration issue:

Because **wind's power increases as its velocity cubed,**

we **really** want to generate wind power where wind speeds are fastest,

which is off our northern coasts, or (for the U.S.) on our Midwestern plains:

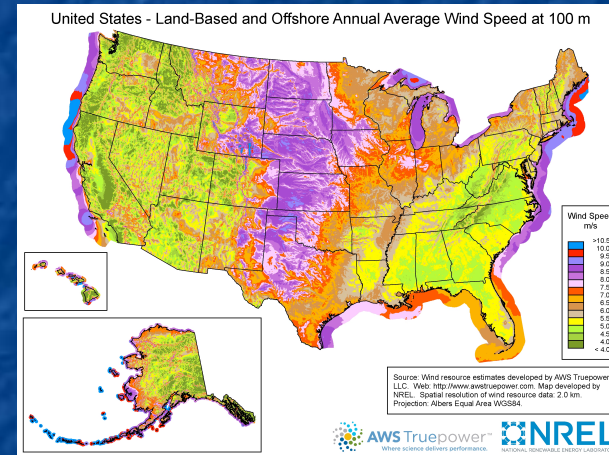
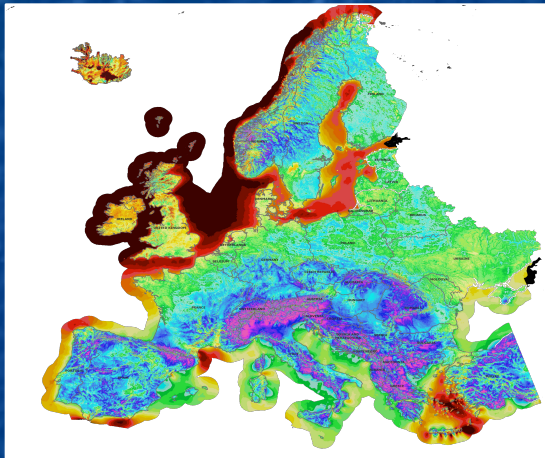

We would then need to transmit that power to our population centers

which are hundreds, if not thousands, of kilometers distant

But, from **Magnetic Induction** ([pptx](#) / [pdf](#) / [key](#)) & **Generic Grid** ([pptx](#) / [pdf](#) / [key](#)) notes:

AC power cannot be efficiently transmitted over such distances!

Large scale use of Wind Power will thus additionally require:

An almost entirely **new, ultra-high-voltage DC power transmission system**

And if this were not enough, if/when we come to rely upon wind (or solar) power,

we will also have to confront their natural daily cycles,

and the fact that they do not produce **power when we most want it**

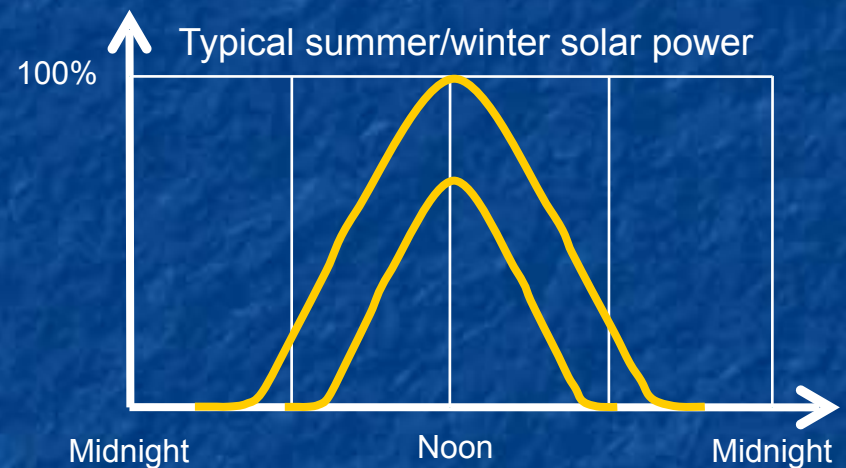
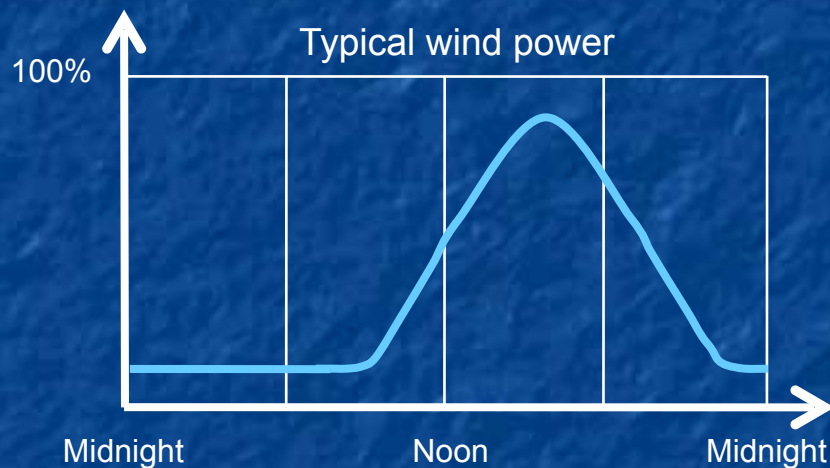

Which will inevitably require the **development & massive deployment** of new

Energy storage systems (see **Power Cycles & Energy Storage** ([pptx](#) / [pdf](#) / [key](#)))

In the U.S. we've avoided those integration challenges . . . thus far

Why? Because wind + solar power still account for < 10% of our total power,

allowing us to use **other power technologies** (often older, dirtier . . .)

to fill in for wind & solar's shortcomings and/or special requirements

How long can we continue to get away with this? Experts say the crunch will come

when wind + solar power grow to contribute ~ 15-20% of our Grid's total power

From **U.S. Power Production** ([pptx](#) / [pdf](#) / [key](#)):

and with wind's **accelerating** growth,

our crunch likely comes by 2030

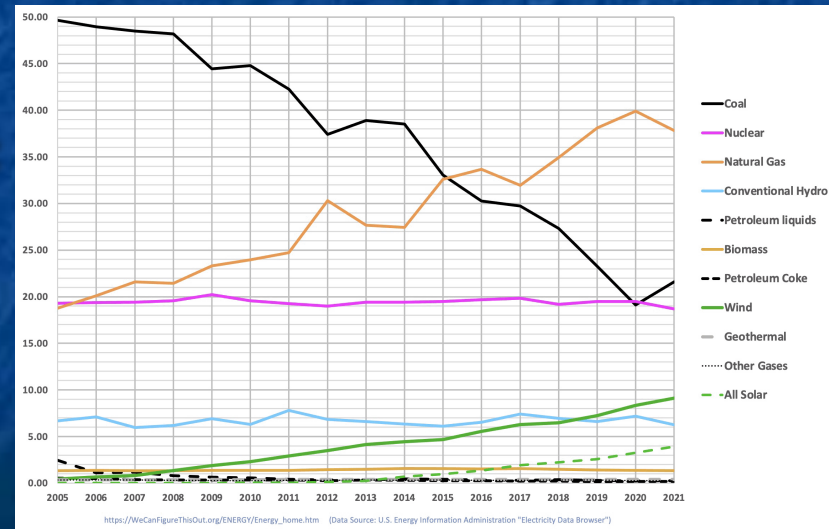

Bringing us to news headlines such as this:

"Australia Has Serious Problems with Green Energy Triggering Blackouts" ¹

Which referred to the Southern Australia (SA) Grid blackout of 28 September 2016

That day a "once in 50 year" storm produced 190-260 kph winds, including two

"almost simultaneous tornados" 175 km apart which knocked out (and down)

three different high-voltage long-distance power transmission lines ²



Within two minutes, their loss caused the SA Grid voltage to dip a half dozen times

Those dips caused power stations to **disconnect** themselves from the grid,

a standard fully-automatic means of protecting them from damage

Those power stations included a large number of new wind farms

1) <http://dailycaller.com/2016/11/23/australia-has-serious-problems-with-green-energy-triggering-blackouts/>

2) https://www.aemo.com.au/-/media/Files/Electricity/NEM/Market_Notices_and_Events/Power_System_Incident_Reports/2017/Integrated-Final-Report-SA-Black-System-28-September-2016.pdf

Picture: <https://www.news.com.au/technology/environment/final-report-reveals-the-causes-of-south-australias-statewide-blackout/news-story/d5499231749c6a858cdc3b4a78f5c7e1>

But while those power plants were protecting themselves:

Other fully automatic Grid switches began attempts at "**load shedding**"

That is, to cut off progressively more of the Grid's customers until

power demand fell to a level that the remaining power plants could supply

"Which power plants, I thought they'd all cut themselves off from the Grid?"

But power plants try (very briefly) to **re-connect** themselves to the Grid

If load shedding has succeeded in cutting demand to a level they can then supply

normal voltages are sustained and the power plants **remain connected**

But if voltages do not stabilize, the power plants disconnect themselves again

And after **a specified number of failed attempts**, they **remain disconnected**

All of this occurs, fully automatically, within tens of seconds

If successful, at least **some customers** then get power from **some power plants**

Allowing human beings to begin work on restoring **the rest of the Grid**

*Wind (tornados) started the problem - But why was **Wind Power** blamed?*



Because of something that happened at some of those new wind farms

Eight of them were programmed to attempt reconnection 9 times

Before the 9th attempt, Grid voltage stabilized and they **remained** connected

But a larger number of wind farms were programmed for fewer attempts

Those wind farms reached their limits **before** Grid voltage could stabilize

And those wind farms thus **ceased** further reconnection attempts

The sustained loss of **their** power was the "last straw" that finally caused a

connector siphoning power from the neighboring Victoria Grid to exceed its limits,

causing it to shut off that emergency power supply, crashing the SA Grid

Cue the blame game / Enter the opportunists:

Both **AEMO** (the responsible power authority) and independent authorities soon initiated in-depth investigations of the event ^{1, 2}

But long before their studies could be completed, politicians rushed in: ³

Australia's Deputy Prime Minister Barnaby blamed wind power for the blackout

Prime Minister Turnbull faulted state governments for neglecting energy security

An SA senator supportive of renewable energy faulted an overreliance on wind

A Queensland senator demanded an end to all climate change reduction policies

The blogosphere went crazy, including misrepresenting loss of embryos at a

fertility clinic (whose back-up generator failed) as the deaths of newborn infants

And Elon Musk rushed in to claim that his new batteries could have saved the day!

1) https://www.aemo.com.au/-/media/Files/Electricity/NEM/Market_Notices_and_Events/Power_System_Incident_Reports/2017/Integrated-Final-Report-SA-Black-System-28-September-2016.pdf

2) https://www.energynetworks.com.au/sites/default/files/ena_response_to_salc_state-wide_blackout_and_subsequent_power_outages_inquiry_april_2017.pdf

3) https://en.wikipedia.org/wiki/2016_South_Australian_blackout

Eventually, the completed studies painted a more nuanced picture: 1, 2

Blame **was** assigned to the **software** at some (but not all) wind farms, which led power/frequency converters to prematurely abandon reconnection attempts

DEEPER FAULT was attributed to under-appreciated changes in the SA Grid

For over a century worldwide grids have been built around huge steam or water-powered turbine generators

Those huge turbines literally have huge momentum (**angular momentum**) meaning that even when disconnected from their grid, they will only

very slowly drift off the rotational speed required for 50 or 60 Hz power

That means that when a grid has been damaged and is attempting to repair itself, power plants can still be disconnected and reconnected as needed,

for seconds or even minutes, without worrying about re-synchronization

But the SA Grid had retired virtually all of its huge turbine power plants

They were replaced largely **by wind farms and gas turbine plants**

Wind turbines DO have momentum, but their modern use of power converters
de-couples the blade momentum from the frequency of their power output

Small gas turbines (a.k.a. jet engines) lack the momentum of huge steam turbines

Thus:

Neither technology (green or non-green) clings to synchronization

This lack of essentially built-in power plant to power plant coordination inhibited
the damaged SA Grid's ability to disconnect and then reconnect power plants

It was also found that it **critically slowed** that Grid's automated process
of **load shedding**, which might otherwise have limited the blackout's extent

Finally, reports faulted the "**skinnyness**" of the SA Grid: ¹

An old-school grid is **fat** in the sense that it consists largely of a

few big central power plants sending power to local/near-local customers

If one radiating line is damaged, only customers down that line loose power

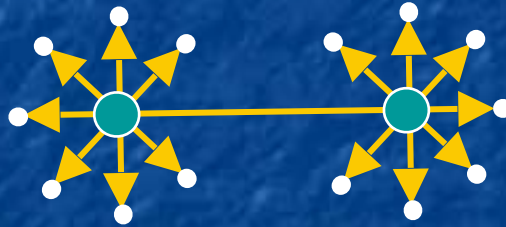

But a **skinny grid** (a.k.a. a **distributed grid**) is a much more complex web

linking together a **much larger number of much smaller power plants**

In such a grid, the local power plant may not be able to supply 100% of local power

Which is acceptable if supplemental power is reliably available from distant plants

Connectivity is essential in renewable/skinny grids, allowing them to deal with

a wind farm's temporary loss of wind, or solar farm's temporary loss of sun

(Longer daily cycles require non-renewable energy or massive energy storage)

1) <https://thediomat.com/2016/10/south-australias-blackout-blame-game/>

The Southern Australia Grid was **exceptionally** renewable & skinny:

Serving a population of ~ 1.7 million residents ¹ (~ same as the city of Philadelphia) ²

Its grid was then ~ **52% renewable**: ³

With overall power then being provided by: ⁴

Solar = Then only via private rooftop installations

Wind = 36 wind farms averaging 98 MW

Gas = 1 large 1.3 GW gas-fired steam plant
+ 1 small 58 MW gas-fired steam plant
+ 12 gas turbines averaging only 140 MW

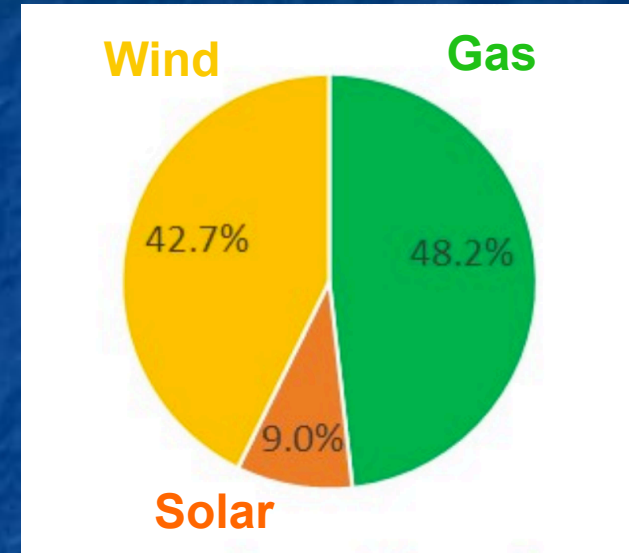

Which, if I've done the math correctly, is 1 power plant or farm per 34,000 residents

1) https://en.wikipedia.org/wiki/South_Australia

2) http://www.citymayors.com/gratis/uscities_100.html

3) <https://www.energycouncil.com.au/analysis/south-australias-blackouts-not-as-simple-as-it-looks/>

4) https://en.wikipedia.org/wiki/List_of_power_stations_in_South_Australia

Bottom line Wind Power integration questions:

Did Wind Power CAUSE the SA Grid blackout? No

Did Wind Power CONTRIBUTE to the SA Grid blackout?

The SA Grid got skinnier (and thus more connection dependent / weather vulnerable)

by closing a few huge central coal power plants and replacing them

with a much larger number of much smaller

non-green gas turbine plants AND green wind farms

Further, dumb software errors are much more likely in **any new technology**

which, in this case, **was** Wind Power technology

Considering all of this, it would seem disingenuous to say Wind Power played no role

Renewable / Distributed Grids WILL present substantial challenges!

Broader Impacts of Wind Power

Onshore Wind Power's Bird & Bat Kills

Here's a good introduction from San Francisco's "Exploratorium" Science Museum:



Doug Bell

Biologist PhD, Wildlife Manager, East Bay Regional Park District

YouTube link to the full video: <https://www.youtube.com/watch?v=NfOZjsOaqSQ>

(I have also cached an edited version of that video on this note set's [Resources Webpage](#))

Do the numbers support Dr. Bell's cautious optimism?

The first impression is NO: Reported wind turbine bird kills appear to be **huge!**

Particularly widely reported ¹⁻³ U.S. numbers include:

888,000 bat kills per year

573,000 bird kills per year

83,000 raptor kills per year

Which leads to online news and blog headlines such as these:

"License to Kill: Wind and Solar Decimate Birds and Bats" ¹

"U.S. Windfarms Kill 10-20 Times More than Previously Thought" ³

"How Much Wildlife Can USA Afford to Kill?" ³

1) <http://dailycaller.com/2015/04/20/wind-turbines-kill-more-birds-than-bp-oil-spill/>

2) <http://instituteenergyresearch.org/analysis/license-to-kill-wind-and-solar-decimate-birds-and-bats/>

3) <http://savetheeaglesinternational.org/new/us-windfarms-kill-10-20-times-more-than-previously-thought.html>

*Those numbers come from the abstract of a **single** research paper:*

As published in the 2013 Wildlife Society Bulletin. Its abstract cites: ¹

"888,000 bat and 573,000 bird fatalities/year (including 83,000 raptor fatalities)"

This is a serious in-depth study, but its purpose was **not** to generate new data

It instead focused on the fact that data exist for only a **fraction of all sites**

And at these sites it's likely only a **fraction of all corpses** were found

For a few better documented wind sites the author thus studied factors such as:

Dispersion of corpses by the turbines, prior removal by scavaging animals,
radius from turbine typically searched, effect of terrain upon discovery . . .

Based on those factors he then proposed **algorithms for extrapolating counts
to likely full kill numbers** (as a function of turbine and terrain parameters)

*Comparing Bird and Bat Fatality-Rate Estimates Among North American Wind-Energy Projects – K. Shawn Smallwood -
Wildlife Society Bulletin 37(1):19–33; 2013; DOI: 10.1002/wsb.260
<http://onlinelibrary.wiley.com/doi/10.1002/wsb.260/abstract>*

But then, using those derived algorithms, he DID:

Count up the total number of 2013 U.S. wind farms,

noting the turbine types, terrain, etc. at each farm

And he then applied his new algorithms to extrapolate kill numbers,

thus estimating a probable overall kill rate total for combined U.S. wind farms

I carefully studied his full paper AND both of its two web-posted data appendices

(Something I strongly doubt most reporters and bloggers bothered to do!)

Assuming its detailed execution was sound, I found nothing to criticize

However, TWO OMISSIONS can cast a different light upon its conclusions:

First, its wind turbine bird kill data need to be put into context

How? By comparing them with TOTAL U.S. human-caused bat, bird & raptor kills

Data such as this:

One of the most complete listings of overall human-caused bird kills:

From the "State of the Birds" organization's 2014 annual report:

Cause:	Annual U.S. Bird Kills:
Cats	2400 million
Building Collisions	599 million
Auto Collisions	200 million
Power Line Collisions	25 million
Telecom Tower Collisions	6.6 million
Power Line Electrocutions	5.6 million
Agricultural Chemicals	N/A
Wind Turbines	0.234 million

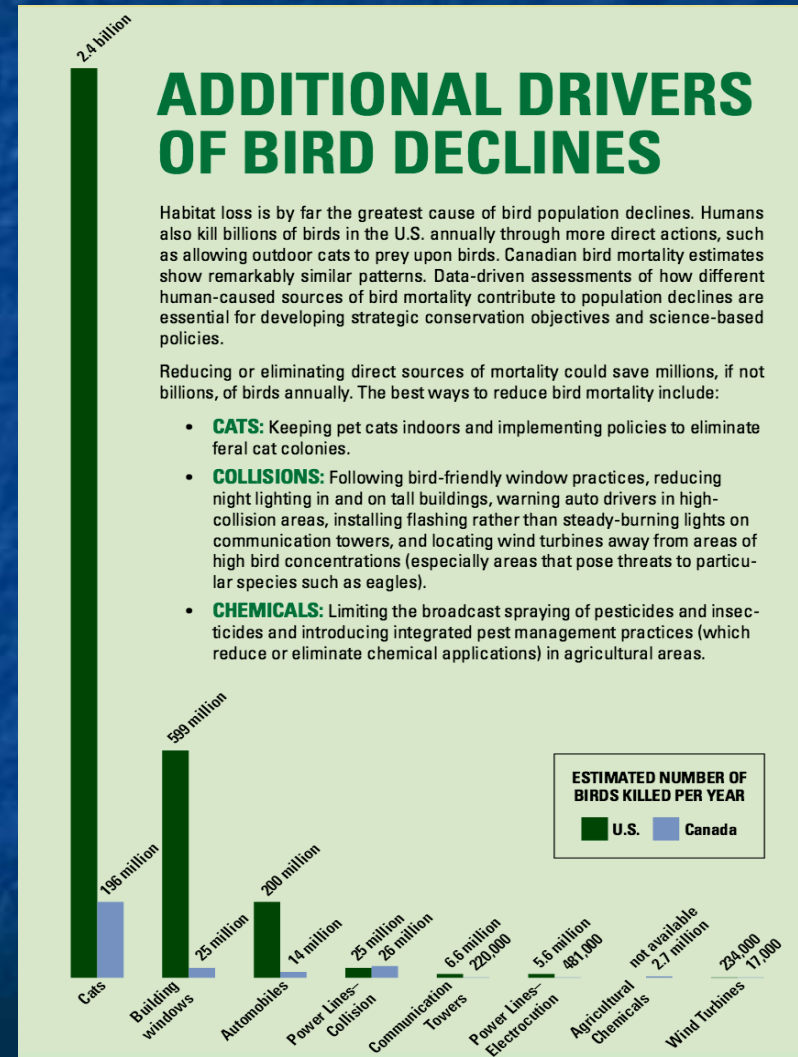

Figure from: http://www.stateofthebirds.org/2014%20SotB_FINAL_low-res.pdf

Which incorporates both prior and later published data from Loss et al.:

2012: <http://www.nature.com/ncomms/journal/v4/n1/full/ncomms2380.html>

2015: <http://www.annualreviews.org/doi/abs/10.1146/annurev-ecolsys-112414-054133?journalCode=ecolsys>

Thus, while wind turbine bird kills are anything but trivial:

Our CATS kill 10,000 times more birds than turbines

Turbines account for only one in 14,000 U.S. bird kills

Or double that if you instead substitute the research study's

extrapolation of 0.573 (vs. 0.234) million turbine-caused bird kills

The study's 2nd omission is seen in a single phrase within its abstract:

**"Adjusted fatality rates correlated inversely with wind-turbine size
for all raptors . . . and for all birds"**

But what exactly does the author mean by "wind-turbine size"?

He briefly discusses an inverse correlation with turbine POWER

But he never makes a correlation with turbine HEIGHT

However, his raw data ARE posted in a separate online "Appendix II" ¹

Using those data, I made that correlation with turbine height:

That Appendix II raw data table begins like this:

Ref	Project name and state or province	Year	Tower ht (m)	Turbine size (MW)	Study size (MW)	All raptors		All birds		All bats	
						Mean	SE	Mean	SE	Mean	SE
1	Buffalo Ridge, MN	2001	50.00	0.750	60.00	0.000	0.000	0.000	0.000	9.330	4.008
1	Buffalo Ridge, MN	2002	50.00	0.750	75.00	0.000	0.000	0.000	0.000	4.526	2.107
1	Buffalo Ridge, MN	1994	36.50	0.340	9.90	0.000	0.000	1.804	1.915	3.401	3.984

Throughout this table, raptor and bird rates appear lower for **taller wind turbines**

Which **was** suggested by Dr. Bell in the earlier Exploratorium video!

After downloading the paper's Appendix II, I copied it data into Excel,

producing these plots of raptor & bird fatalities versus tower height:

Raptor Fatality Rate vs. Tower Height (m)

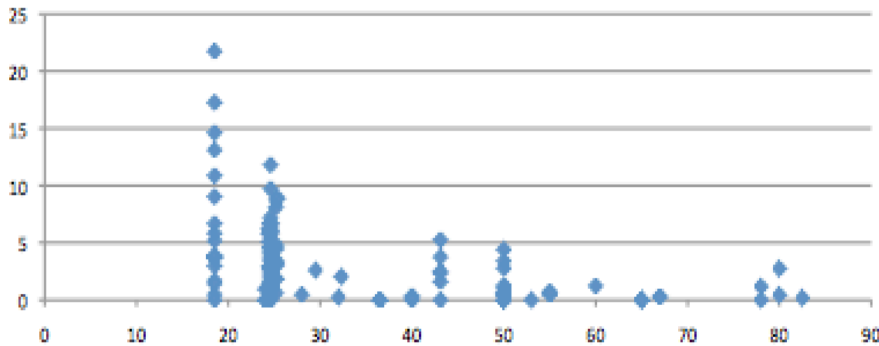

Bird Fatality Rate vs. Tower Height (m)

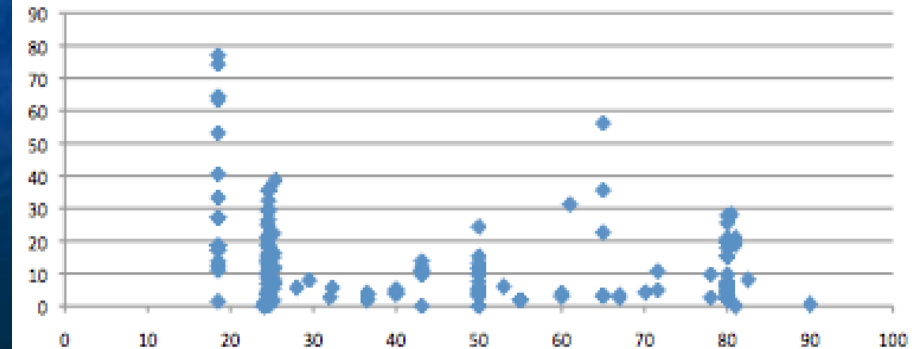

(Again!) WE know why & how wind turbine height has been increasing:

Wind speed increases (and power vastly increases) with height above the ground, driving strong year-by-year increases in new wind turbine height and power



Most of this study was for old wind farms with turbine towers of **< 40 meters**

versus modern wind farms with towers \geq **100 meters** (now climbing to 150 m)

By simply correlating this study's raw data with turbine tower height

I find that fatality rates for taller towers are as much as 5X lower!

Further, because large turbines produce more power (again by perhaps 5X)

Kill rates PER MW POWER PRODUCED might be AT LEAST 10X LOWER!

But for bats my correlation suggests that taller towers might be worse:

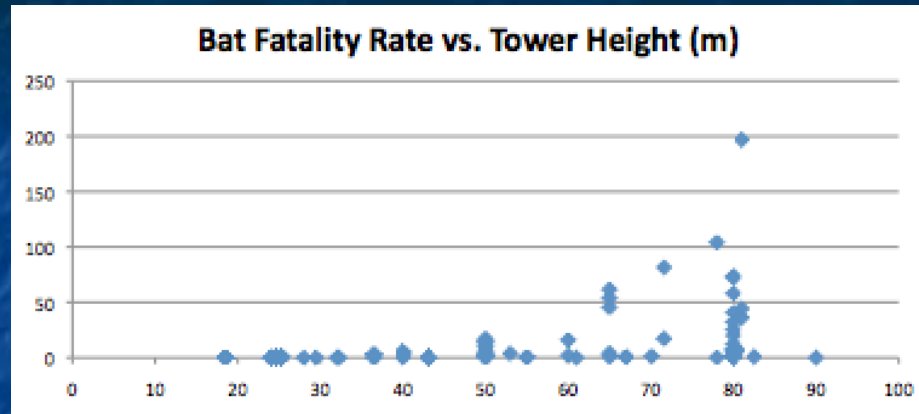

Then, bizarrely, it was reported ¹ that bats might avoid colored turbines

Why? Because bats (and some birds) are attracted by flying insects,

and insect attraction to color goes as: Yellow > White or Gray > Purple

Which came from the U. Loughborough Ph.D. thesis of Ms. (now Dr.) Chloe Long ²



The Brave New Purple World of wind power?

Or might we just alter turbines' invisible (to us) UV color?

1) <http://www.treehugger.com/renewable-energy/wind-turbine-color-makes-difference-in-bird-bat-deaths.html>

2) <https://dspace.lboro.ac.uk/2134/8041> Figure from: <http://www.iconsdb.com/violet-icons/wind-turbine-icon.html>

The conclusion of leading avian advocates:

The **Audubon Society** is probably the oldest and largest U.S. bird advocacy group

They are thus very aware of, and very concerned about, the above bird kills

But they are also very worried about the impact on birds due to

habitat loss (e.g., by corn methanol farming) and climate change

Which led to the "Audubon's Position on Wind Power" which states: ¹

"Audubon strongly supports properly sited wind power as a renewable energy source that helps reduce the threat posed to birds and people by climate change.

However, we also advocate that wind power facilities should be planned, sited, and operated in ways that minimize harm to birds and other wildlife, and we advocate that wildlife agencies should ensure strong enforcement of the laws that protect birds and other wildlife."

Proper siting is essential because raptor deaths can be sharply reduced by avoiding their often specific, narrow, mountain migration flight paths

1) <https://www.audubon.org/content/audubons-position-wind-power>

Offshore Wind Power's effect upon sea life

Life IN the seas:

Man has been building ocean oil & radar platforms for at least 75 years

And, of course, our ships have been sinking in those seas for millennia

In the absence of chemical leakage, their impact has been **surprisingly favorable**:

Mollusks & corals rapidly colonize those hulks, attracting fish and other sea life

See for instance the NY Time's 2016 article & video:

"Marine Life Thrives in Unlikely Place: Offshore Oil Rigs"



<https://www.nytimes.com/2016/03/08/science/marine-life-thrives-in-unlikely-place-offshore-oil-rigs.html>

NY Times [Link](#)

(I have also cached a copy of that article & video on this note set's [Resources Webpage](#))

Do offshore wind farms have a similar effect?

A recent study simulated the likely effect of multiple North Sea offshore wind farms ^{1, 2}

It concluded that wind farms could increase the North Sea's overall blue mussel population by as much as 40%

Filter-feeding mussels makes the water clearer,

increasing "the degree of habitat complexity,

encouraging a higher level of species richness"

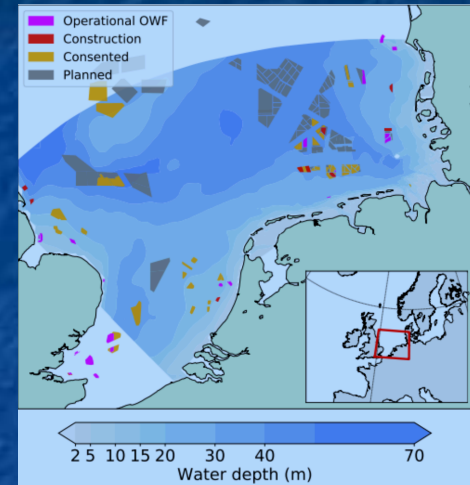

But it was noted that rich, new, and isolated environments such as these

might also provide locations for new invasive species to gain a foothold

But that concern should apply equally to offshore oil platforms & wrecks

Suggesting that, while further study is necessary, offshore wind farms

could well reproduce the positive impacts of both oil platforms & shipwrecks

1) 2017 MIT Technology Review news article about the study:

<https://www.technologyreview.com/s/608930/first-evidence-that-offshore-wind-farms-are-changing-the-oceans/>

2) The 2018 study itself: <https://arxiv.org/pdf/1709.02386.pdf>

What about life ABOVE the seas (e.g., birds)?

I do not know of studies yet done on possible bird kills due to offshore wind farms

The seminal wind power bird kill study (discussed at length above)

highlighted how difficult it is to assess mortality rates **onshore**

(e.g., corpses going missing due to scavenging or being hidden in vegetation)

I'd thus assume recovering & counting bird corpses offshore would be ~ impossible

Leaving alternatives such as collecting data on bird migration routes & altitudes

And then constructing probabilistic models of bird / offshore turbine collisions

(But I'd personally doubt the accuracy of such models until they were

also able to account for corpse-verified **onshore** bird kill rates)

OR one might very, very carefully monitor post-migration bird populations

looking for changes after construction of offshore wind farms in migration paths

(Which would still leave uncertainty as to if wind farms were responsible)

Wind Turbine Noise:

Many research studies have recorded wind turbine noise

and reported on their detailed (and often obscure) sound spectra analyses

Some of these studies have searched for adverse **physiological** effects

including those which might be produced by ultralow frequency sound

None of the studies that I found claimed to have documented any such effects

But what about the possibly very real **psychological** impact of wind turbine noise?

I searched for videos that would allow me to judge that for myself

The sound levels in MOST videos SEEMED very, very loud

But those levels were not quantitatively measured,

nor did the videos include other sounds that could have provided a reference,

and electronic noise led me to suspect that audio levels had been jacked up

I then found this video recorded by one of Britain's major newspapers

With a **Decibel Noise Meter** in hand, **The Telegraph** newspaper visited:

A nature preserve, rural town, London, highway, airport approach & **wind farm**

This video's loudest message may be about **always questioning** web-postings!



YouTube link: <https://www.youtube.com/watch?v=zKgN2G9d0dc>

(I have also cached a copy of that video on this note set's [Resources Webpage](#)

NIMBY – Not in My Backyard!

The biggest NIMBY objections to wind power are its noise and visual impact

Neither is a clear cut technical issue, they both invoke personal judgments

Thus (for better or worse) let me now take a very personal approach to NIMBY:

Regarding noise:

Wind Power - Part I ([pptx](#) / [pdf](#) / [key](#)) notes described how the common Danish turbines operate at blade tip speed ratios (TSRs) of ~ 5 , meaning the fastest parts of their blades move at 5X the ambient wind speed

That note set's maps also showed that faster wind farm winds might move at 8 m/s which is equivalent to ~ 18 mph (or 29 kph)

Combining those two pieces of information:

Wind farm turbine blade tips typically move at ~ 90 mph (150 kph)

With inner parts of the blades moving at progressively lower speeds

Those speeds & sizes are roughly comparable to freeway traffic

Which is indeed what I believe I heard confirmed in

The Telegraph's exceptionally careful (and honest) video of two slides ago

I live a bit over a kilometer from a freeway (and I **am** happy for that distance)

but my neighbors living much closer to the freeway do not complain of noise

The above experience + the video's information thus lead to

My personal (subject to possible revision) conclusion about **wind turbine noise**:

For other than a small number of rural residents who are actually living

within the bounds of an active wind farm (as **might** occur in the Midwest),

wind farm noise does not appear to be a valid NIMBY objection

Regarding visual impact:

While I have never lived ON the coast, I grew up within easy driving distance of some of the west coast's most beautiful ocean vistas

and I thus cherish ocean views, including their clear open expanses

I can thus empathize coastal residents, such as even those on Martha's Vineyard (even if I never stood a chance of ever living there myself!)

But my horizon calculations & view simulations now convince me that:

Wind farms \geq 15 km offshore would **not** significantly compromise such vistas



*But what about my **actual** backyard?*

My Backyard's Status Quo:

Up Wind: Immediately behind those mountains is West Virginia, powered ~100% by coal, with coal's air pollution restrictions now being slashed!

Down Wind (hopefully): Two 40 year old nuclear reactors, now passing their design lifetime, but continuing to operate because their modern safer replacements are in political limbo!

My Backyard's Possible Future (swap the images):

Wind turbines intruding upon my view?

Given the alternatives, I could live with that

(Power can't ALL come from "elsewhere!")

PgUp



But here in Virginia, offshore wind power WOULD be immensely more productive!

Credits / Acknowledgements

Some materials used in this class were developed under a National Science Foundation "Research Initiation Grant in Engineering Education" (RIGEE).

Other materials, including the WeCanFigureThisOut.org "Virtual Lab" science education website, were developed under even earlier NSF "Course, Curriculum and Laboratory Improvement" (CCLI) and "Nanoscience Undergraduate Education" (NUE) awards.

This set of notes was authored by John C. Bean who also created all figures not explicitly credited above.

Copyright John C. Bean

(However, permission is granted for use by individual instructors in non-profit academic institutions)