

The Fictions (?) of Nano Science Fiction

A central goal of this class is to try to figure out where nanoscience is taking us

But we've got to keep reminding ourselves that "We're not in Kansas Anymore!"

That is, that Nano is governed by a very different set of rules

Which makes simple extrapolation of present-day technology almost useless

Meaning that a lot of imagination will instead be required

To provide that, today I want to call upon professional "imagineers" of technology:

The Authors of Science Fiction

And there is a LOT of speculation about NANO in Sci-Fi:



For even more nano titles, see LibraryThing's list at:
www.librarything.com/tag/nanotechnology

What is one of the most prevalent themes? Nanobots!

From the book and 1966 movie *Fantastic Voyage*:

Where medical team + sub are shrunk to treat an injured diplomat – **from the inside!**



OK, shrinking down people may be ridiculous

But in nanomedicine aren't we already pretty close to proposing Nano ROVs?

What **MIGHT** be the limits of a such a programmable nano machine?

To answer we MUST take scaling into account:

At human scales (and larger) we are VERY concerned with MOMENTUM

We are a little bothered with FRICTION

But we almost ignore SURFACE TENSION, CHARGING, Van der Waals . . .

(The latter tend to counter momentum - but not very well)

But the balance of forces changes as things get smaller:

Momentum \propto Mass \propto VOLUME = L^3

But ALL of the other above forces depend on contact AREA = L^2

Are you sure about charging (a.k.a. "electrostatics")? Yes:

Because if object gets charged, repulsion of charges forces them to surface

So charge carrying capacity of the object varies as its surface area

So what happens when we scale down?

From human (1 meter) scale to micro (1 micron) scale:

Mass and Momentum $\rightarrow (10^6)^3 = 10^{18}$ times smaller

All of the other surface dependent things $\rightarrow (10^6)^2 = 10^{12}$ times smaller

Making friction, surface tension, charging, VDW, a million times more important!

Becoming a billion times more important at the nanoscale!

Don't have to go even THAT far - Shift in forces is evident at MILLI (1mm) scale:

It's why ants can fall unharmed from a million times their height

Δ Momentum tries to tear them apart - Charge (H-bonds) & VDW help hold them together

Ratio of cohesive to destructive forces is 1000 times more favorable

After fall, ant happily walks up a wall (exploiting the SAME shift towards cohesive forces)

Must also take wave behavior into account:

Most electromagnetic waves are **much larger** than a nanometer

Radio waves are instead measured in millimeters to meters

Even the shortest visible light (blue) has a wavelength of ~ 400 nanometers

(Have to go all the way to X-rays or gamma rays to get into the nanoscale!)

With the consequences that:

Waves incident upon nano things will not change direction

Waves emitted by nano things will radiate outward in simple circles

And waves become circular if forced to pass through nano gaps

Relevance to science fiction Nanobots?

Don't expect to see nano versions of transformer-like mechanical robot

Even if we COULD make and assemble nanoscale equivalent pieces

the balance of forces, light interaction etc. would be totally changed!

So how MIGHT you make a nanobot? Seem to be two (overlapping) paths:

1) Build very simple mechanical mechanisms:

Few or no sliding parts (VERY carefully engineered!)

When need movement, use natural (strong) forces to flex and bend

2) Follow biology's lead: Genetically alter / program cells, viruses . . .

But is a Pandora's box, tinkering with processes we incompletely understand

(Creating things that might happily infest our own bodies!)

Requirements for an effective / entertaining SF nanobot:

SF Nanobots generally build or destroy things big enough to affect people, so:

REQUIREMENT #1) Nanobots needed in HUGE number (moles of them!!)

Only way to get $\sim 10^{23}$'s of them is if **nanobots can replicate themselves**

Problem: If can replicate themselves, how do we LIMIT their population?

Possibility and problem discussed long ago by mathematician John von Neumann

Hence: Self-Replicating Machines => "Von Neumann Machines" (staple of SF)

Or, if bio-based, Drexler called possible out-of-control growth "The Gray Goo"

So REQUIREMENT #1 has possible side-effect of annihilating all other lifeforms

Other requirements for effective / entertaining SF nanobot:

REQUIREMENT #2) Nanobots must be able to see

So they can spot their prey - frequently, us!

REQUIREMENT #3) Nanobots must be able to communicate

So they can coordinate their actions - frequently, against us!

REQUIREMENT #4) Nanobots must be able to control their motion

So they can come after us!

And implicit in requirements 2-4 is the assumption of:

REQUIREMENT #5) Nanobot must think, or at least be programmable

SANITY CHECK: Pause to compare with biology:

After all, the closest thing we've currently GOT to a nanobot is a biological cell!!

How well do cells satisfy above "requirements"?

- **Satisfy** requirements 1 & 5: Replication & programmability
- **Flunk** requirement 2: Cannot see
- **Poor** on requirement 3: Communicate only via randomly dispersed chemicals
- **Lousy** on requirement 4: Move almost entirely by "going with the flow"

Given that nature has had a few billion years to try out a huge number of schemes, sort of suggests there might be flaws in our SF nanobot "requirements"

But let's charge ahead anyway!

Requirement #1: Nanobot Replication

The Beauty of a circular argument (allowed in fiction if not in fact):

If I really CAN make an effective nanobot

In addition to destroying things that nanobot will be able to **make** things

So as its second priority task (to occupy its spare time)

I'll program it to make copies of itself!

(it works for all of us macrobots, why shouldn't it work for nanobots?)

So the assumption of an **effective** nanobot **guarantees** replication!

Requirement #2: Nanobot Vision

Example: Crichton's "Prey" invokes an eye created by nanobot swarm

Begins as manmade attempt to build micro-eye for medical diagnostics

"Eye" moves through circulatory system (w/o causing strokes)

Thus "eye" assembly **MUST** not be larger than red blood cells = 6 - 8 microns

HOW does it work? Nanobots form sphere with light entrance hole (i.e. like an eye!)

IMMEDIATE PROBLEM: Assumption that light enters **ONLY** via hole in sphere

Nanobots may not be opaque to light: Even multiple layers of nanobots

Cells, or **MANY** layers of cells, sure aren't opaque (e.g. translucent skin)

(Will ignore this possibly critical initial problem)

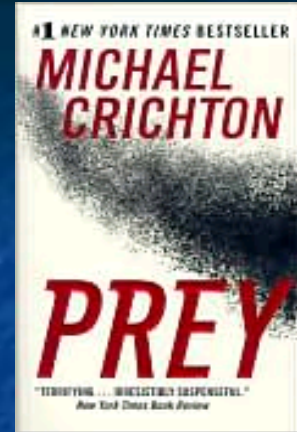

So basic idea is that of a pinhole camera / camera obscura:

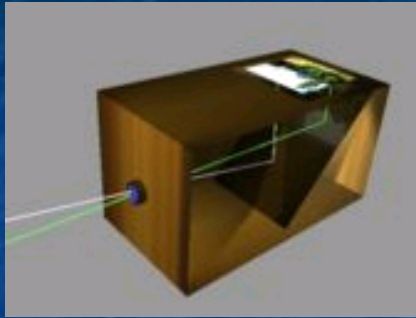

http://en.wikipedia.org/wiki/Camera_obscura

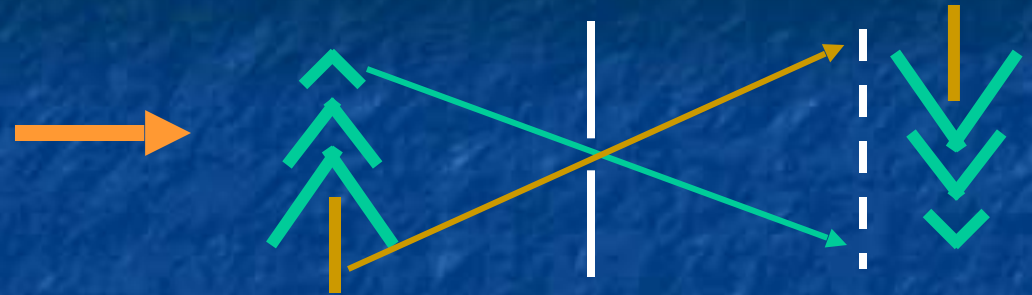

Critical advantage of pinhole camera is that you do not need a lens

If assume light moves in straight lines, through tiny hole,
light from every point of object should project onto different point on screen

Thus producing image (albeit, upside down)

Used in earliest cameras

Also used in modern X-ray cameras (because cannot build lenses for X-rays!)

How tiny a hole is required?

Crichton's micro-eye is only ~ 7 micron in total diameter

Back imaging area of sphere is thus $\sim 1/2 (4 \pi r^2) = 2 \pi (3.5 \text{ micron})^2 \sim 75 \text{ micron}^2$

What if want nanobot eye to see as sharply as image on PC screen?

PC screen $\sim 1024 \times 768$ pixels $\sim 800,000$ pixels

All of which must fit into that 75 micron^2 area on the back surface of this eye

So area per pixel = $9.4 \times 10^{-5} \text{ micron}^2 \sim (10 \text{ nanometers})^2$

Smaller the hole in the eye, smaller the beam from each point, smaller its pixel:



How tiny a hole is required (continued)?

So, hole in Crichton's nano-eye should be ~ 10 nanometers in diameter, right? Problem:

Lecture 2 / Water ripple tank labs:

Waves strongly DIVERGE when slit $< \lambda$

Due to **DIFFRACTION!!**

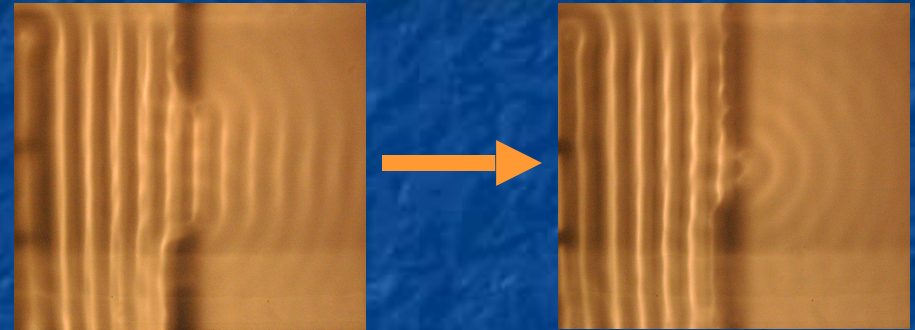

SHORTEST wavelength light (blue) ~ 0.35 micron = **350 nanometers** = OOPS!

Micro Eye's opening = 10 nm \ll 350 nm wavelength \Rightarrow a LOT of diffraction spreading:

Macro eye + large aperture

Macro eye + small aperture

Micro eye + nano aperture

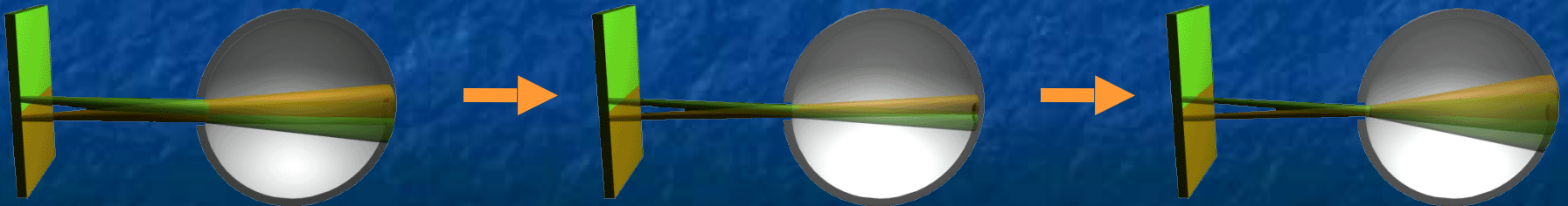

How to quantify?

It's a combination of simple light projection through / light shadowing by aperture:

That is, assumption of light moving in exact straight lines

Plus diffraction spreading of individual light "beamlets":

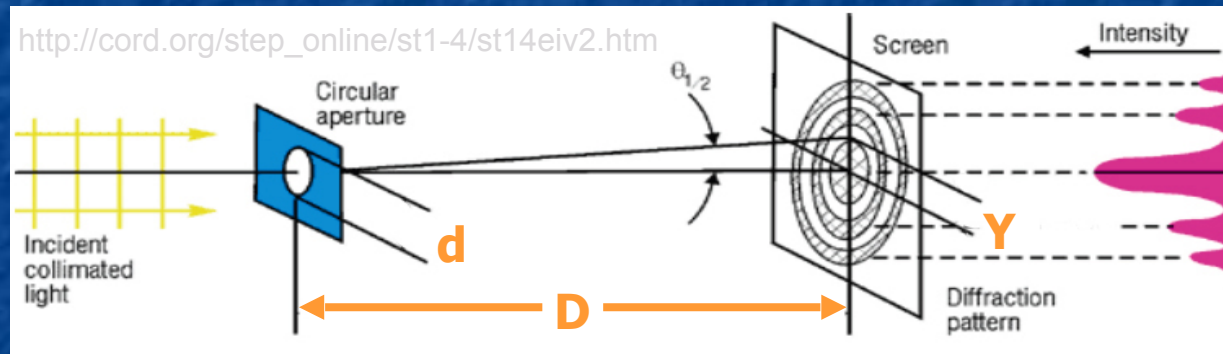

Exact solution very difficult, but approximation was proposed by J.M. Petzval in 1857:

Suggested just taking the sum of the two above phenomenon:

Shadow of aperture + edge "Fraunhofer" Diffraction spread =>

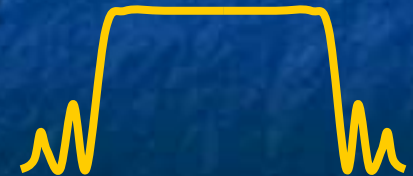

Comes directly from our ripple tank images:

Waves through a small aperture:

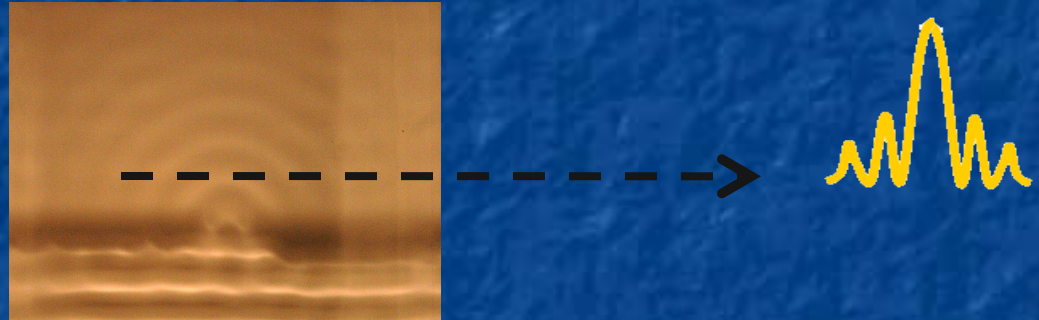

Waves through a larger aperture:



Petzval's equation fitting this behavior:

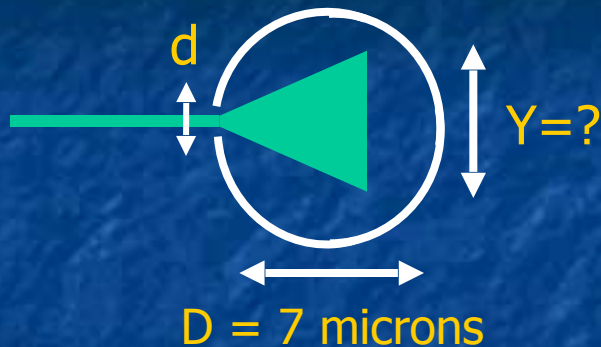

D = Diameter of "eye"

d = Width of eye's opening (aperture)

Y = Width of pixel (beam's spread at back of eye)

From Petzval's analysis of pinhole camera design:

$$Y \sim d + 2 \lambda D / d = \text{projection of aperture} + \text{diffraction spread at edges}$$

Makes sense - size of aperture (d) enters twice:

For LARGE eye and aperture ($D, d \sim$ same order of magnitude): $Y \Rightarrow d + (\sim\lambda) \Rightarrow d$

But for small aperture, second term (diffraction) blows up: $Y = 2 \lambda D / d$

Plugging in some numbers

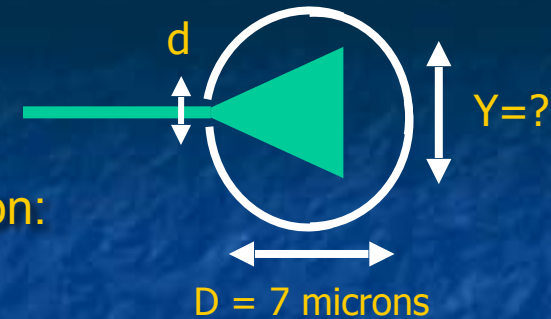

Creighton's eye + blue light + our hope for PC like resolution:

$$Y = d + 2 \lambda D / d \Rightarrow 10 \text{ nm} + 2 \times 350 \text{ nm} \times 7 \text{ micron} / 10 \text{ nm}$$

$\sim 500 \text{ microns}$ But entire eye is only 7 microns tall (!@#@#!)

So back off and instead enlarge aperture to 100 nm:

$$Y = d + 2 \lambda D / d \Rightarrow 100 \text{ nm} + 2 \times 350 \text{ nm} \times 7 \text{ micron} / 100 \text{ nm} = 50 \text{ microns (!@#@!)}$$

Finally, in desperation, try a 1000 nm (1 micron) aperture:

$$Y = d + 2 \lambda D / d \Rightarrow 1000 \text{ nm} + 2 \times 350 \text{ nm} \times 7 \text{ micron} / 1000 \text{ nm} = 5 \text{ microns}$$

Single pixel $\sim 25 \text{ micron}^2$

Back of eye $\sim 75 \text{ microns}^2 \Rightarrow$ Max of about 3 pixels

Or perhaps more accurately . . .

Formula above assumed “screen” was many, many wavelengths back from aperture

So that the screen would be in the “far-field” wave distribution

But Creighton’s nano eye was max of ~ 20 light wavelengths in diameter = “near field”

To model accurately, need full simulation of near-field “Fraunhofer” diffraction pattern

Which I actually found in a [paper on X-ray camera design](#) by K. Mielenz of NIST !!

He suggested actual resolution is about 4X better than Petzval’s formula

So final 1 micron aperture “eye” (above) actually yields ~ 1 micron beam / pixel width

With 75 micron² imaging area on back of sphere could then fit ~ 100 pixels

Revised number IS more consistent with our experience:

In ripple tank labs / simulations for lecture 2, beams only blew up when gaps $\Rightarrow \lambda$

$d \sim 10 \lambda$:

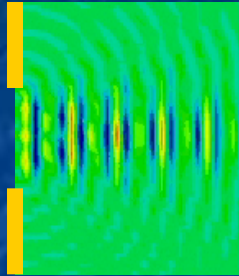

$d \sim 5 \lambda$:

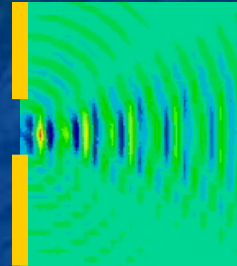

$d \sim 1 \lambda$:

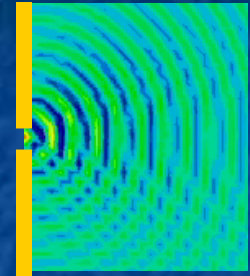

Means 1 micron aperture **should** be \sim optimum for tight beams of all light colors:

Aperture (1000 nm) = (2 to 3) \times (350 - 600 nm) = (2 to 3) $\times \lambda$ light

Thus for Crichton's 7 micron eye, best 1 micron aperture design $\Rightarrow \sim$ 100 pixels total

Cover of "Prey" at
normal resolution:

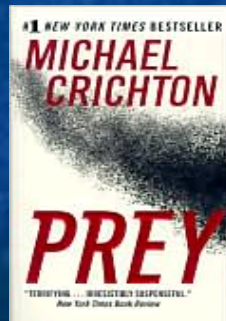

Cover of "Prey" at
100 pixel resolution:

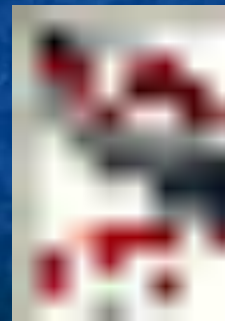

*Happy hunting
nanobots!*

What about Creighton's later eye based on large CLOUD of nanobots?

With eye size increased from 7 microns to 1-2 meters, resolution no longer a problem:

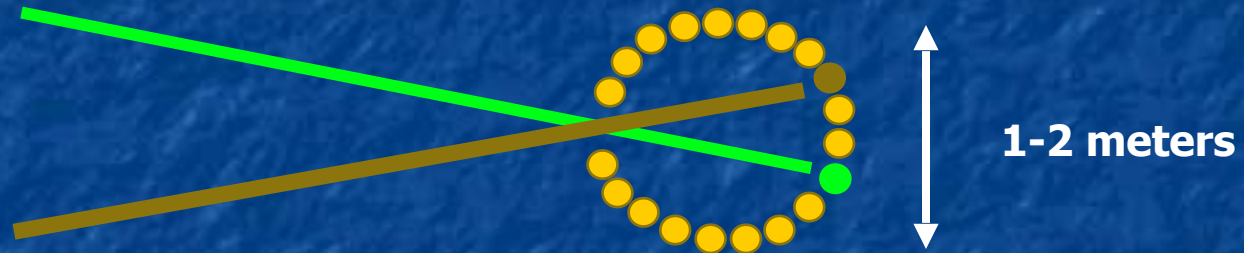

But still have problems with:

- a) How do individual nanobots determine their desired position in macro eye?
- b) How do individual nanobots MOVE to that desired position in macro eye?
- c) How do individual nanobots COMMUNICATE their illumination & position?
- d) How (where and by what) is cumulative information processed into image!!!!

First: Tackle generic nanobot REQUIREMENT (#3 on earlier pages) of communication

Requirement #3: Nanobot Communication

Given trouble we had with nano vision, maybe we should now mimic biology:

Alternative a) Communication via chemicals?

Chemical = Molecule => ballpark volume of $(1 \text{ nm})^3$

To qualify as a nanobot, its size shouldn't exceed $(100 \text{ nm})^3 = 10^6 \text{ nm}^3$

So nanobot would only consist of at most $\sim 10^6$ molecules

Nanobot better not waste molecules (using itself up) => Needs closed environment

But if nanobots themselves CREATE required enclosing shell = MACRO BODY

That is: human beings ARE enclosures (via skin cells) of nanobots (more cells)

So that practical chemical communication requires a non-nano body = **cheating**

Nanobot Communication (cont'd)

Alternative b) Communication via sound?

NO WAY individual nanobots are going to be able to set up significant sound vibrations!

Alternative c) Communication via photons (light, radio . . .)?

Nano things certainly CAN emit and absorb photons

Analyze in terms of WHERE energy would come from and likely SIZE of photons

Outside of nutrient rich macro living bodies, best energy source = SOLAR ENERGY

This IS what Crichton proposed for his nanobots!

For clear sky, at noon, on equator, solar illumination $\sim 1 \text{ kW} / \text{m}^2$

Nanobot max surface area $\sim (100 \text{ nm})^2$ With 100% efficient light conversion:

Nanobot max solar power = $(1 \text{ kW} / \text{m}^2) \times (100 \text{ nm})^2 = 10^{-11} \text{ watts}$

Solar powered nanobot communication:

But I like to think at molecular level (and was trained as physicist) so converting:

$$10^{-11} \text{ watts} = 10^{-11} \text{ Joules / s} = 10^{-11} \text{ Coulomb - Volts / s} \sim 6 \times 10^8 \text{ eV / s}$$

Pretty respectable number, particularly if nanobot rationed it carefully

But energy is captured in molecular reconfigurations, e.g. ADP => ATP

“Adenosine diphosphate” => “Adenosine triphosphate” (Textbook section 10.3.3.2)

And released into communicating photons by reverse reaction, e.g. ATP => ADP

Energy released? ATP => ADP releases ~ 7 kcal / mole:

$$7 \text{ kcal / mole} = 7 \times (2.6 \times 10^{22} \text{ eV}) / (6.02 \times 10^{23}) \sim 0.3 \text{ eV}$$

Dividing nanobot max solar power into photons of this size => 2×10^9 photons / s

Are 2×10^9 photons / sec enough?

What are odds of a given photon successfully reaching desired partner nanobot?

Crude estimate: If nanobots separated by R , probability \sim nanobot area / $4 \pi R^2$

That is, proportional to fraction of surrounding sphere that partner nanobot occupies

$$P(R) \sim (100 \text{ nm})^2 / 13 R^2$$

$$R = 1 \text{ micron} \quad \Rightarrow \quad P = 8 \times 10^{-4}$$

$$R = 1 \text{ millimeter} \quad \Rightarrow \quad P = 8 \times 10^{-10}$$

$$R = 1 \text{ meter} \quad \Rightarrow \quad P = 8 \times 10^{-16}$$

With 1 micron nanobot spacing, need to send 1300 photons for partner to receive 1

With nanobot's 2×10^9 photons per second could send 1 Mbit/sec of info to partner

So solar powered photons MIGHT work for communication

But prospects worsen quickly with larger separations

What about other nanobot requirements?

REQUIREMENT #4) Nanobots must be able to control their motion

No way! See our textbook's chapter 9 on Nanoscale Fluid Dynamics

It provides the hard numbers to back up the phrase "blowing in the wind"

That is, submicron particle in a fluid or even in the air, has \sim no control over where it goes

In Prey, Crichton DID anticipate problem by saying nanobots only came out in still air

But even in still air, nanobots are going to "swim" with nano speed:

No way they could swarm out of caves 100's of meters away

Or keep up with fleeing humans (both of which "occur" in Prey)

Leading me to a final nanobot score card:

Overall nanobot scorecard:

REQUIREMENT #1) Nanobots must self-replicate:

PLAUSIBLE

Based on circular argument (or copying the one proven technique = bio-reproduction)

REQUIREMENT #2) Nanobots must be able to see:

BUSTED

REQUIREMENT #3) Nanobots must be able to communicate:

PLAUSIBLE

But **only** when very close (e.g., when large numbers confined to small spaces ~ cheating)

REQUIREMENT #4) Nanobots must be able to control their motion:

BUSTED

REQUIREMENT #5) Nanobots must be programmable:

PLAUSIBLE

Didn't really discuss: Conclusion based on existing bio examples (discuss more in lecture 13)

How natural nanobots (cells) nevertheless succeed:

They DELETE the two preceding failed requirements:

REQUIREMENT #2) Nanobots must be able to see:

They don't SEEK out things, they are taken all over the place (see below)

But RECOGNIZE (via chemistry and/or shape) when they've arrived where they want to be

REQUIREMENT #4) Nanobots must be able to control their motion:

Fluid motion (flow and diffusion) take them EVERYWHERE inside their space

Nevertheless they get to specific required THERE fast enough (textbook page 329-30):

Time for complete cell mixing = $(\text{Cell Diameter})^2 / (\text{Diffusion Coefficient of Molecule})$

=> 40 milliseconds for 2 micron cell

Time for any 2 molecules to contact = $(\text{Cell Dia.})^3 / (\text{Diffusion Coefficient of Mol.}) (\text{Mol. radius})$

=> 400 milliseconds for 2 micron cell and 10 nm radius molecules

If my Sci-Fi imagineers blew nanobots, did they get anything right?

Or, at least, anything right with respect to nanoscience / nanotechnology?

Strangely, Nano may soon make one of Sci-Fi's BIGGEST ideas possible:

The "Beanstalk"

Proposed by Arthur C. Clarke in his 1979 novel "The Fountains of Paradise"

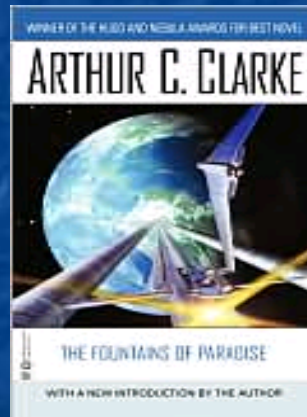

But what is a Beanstalk?

This is a Beanstalk:

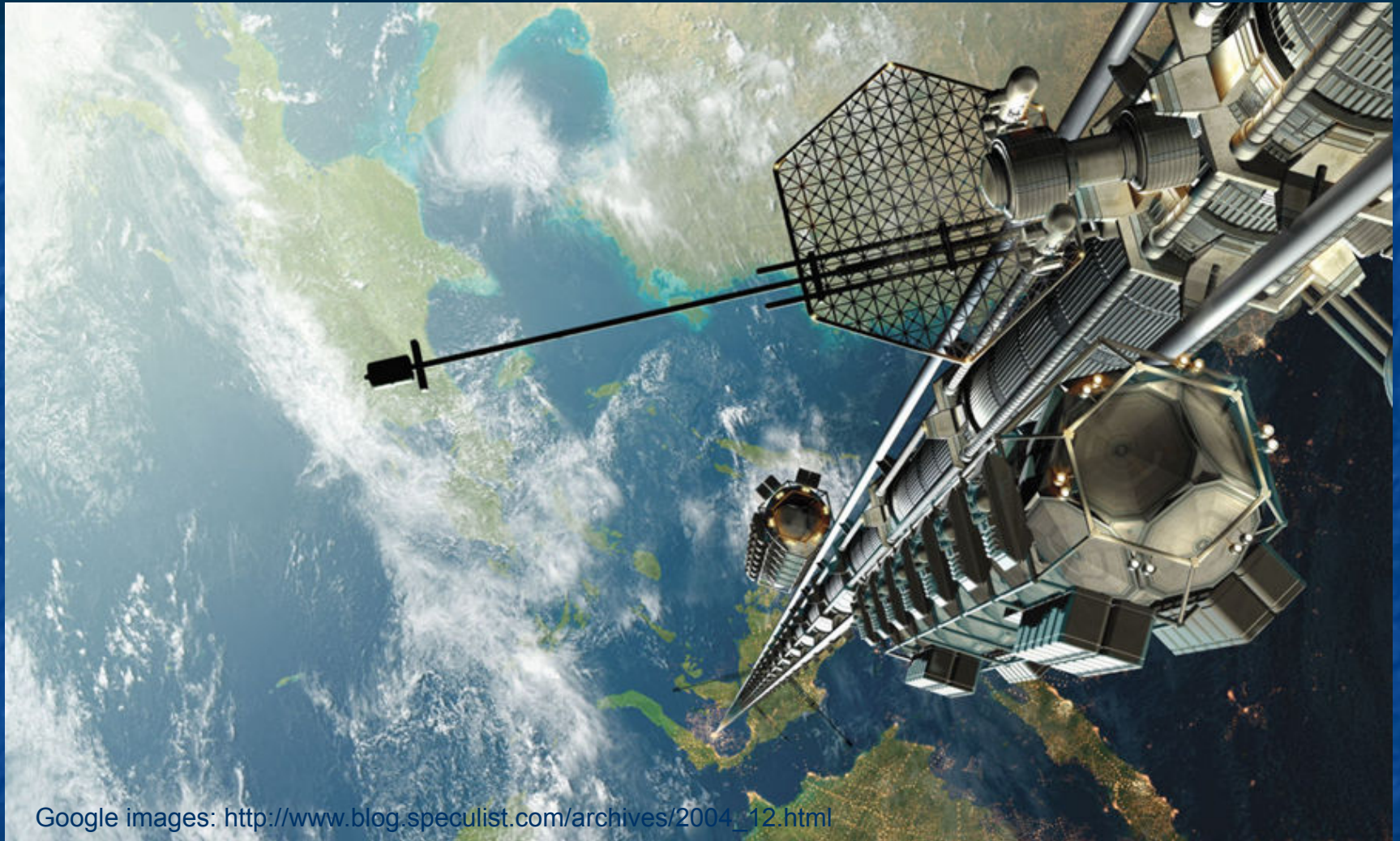

Google images: http://www.blog.speculist.com/archives/2004_12.html

Also known as a "Skyhook" or as a "Space Elevator"

A Hands-on Introduction to Nanoscience: WeCanFigureThisOut.org/NANO/Nano_home.htm

It's actually an old idea . . . But with a BIG problem

Proposed by Russian scientist Konstantin Tsiolkovsky, in 1895

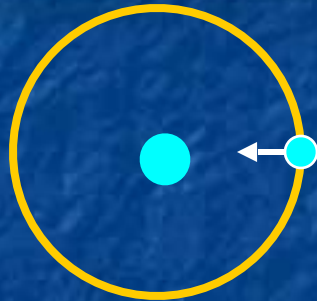

Satellite's orbit = balance between centrifugal force & gravitational force

Higher it goes, weaker the gravity, slower the orbit required

Near-earth orbit ($R \sim 6,500$ km) ~ 90 minutes

Moon orbit ($R \sim 385,000$ km) ~ 30 days

35,786 km orbit = one day \rightarrow Over equator, stays above fixed point \rightarrow "Geosynchronous Orbit"

Tsiolkovsky: Satellite is happy, earth is happy, tie together with rope + elevator

Problem: **Rope is not happy**, all but top of it is moving too low and slow to orbit

Load on rope \Rightarrow Good fraction of its own 35,000 km length \Rightarrow SNAP!

Need incredibly LIGHT yet STRONG rope!!!

Analysis by U. Washington Physics Prof. John G. Cramer:

In his December 2001 [Alternate View](#) column in Analog Magazine ([link to cached copy](#))

Tension at top of rope = 92 Giga Pascals = 13.3 MILLION pounds per square inch!

But he also estimates that: **Carbon nanotube (CNT) rope might attain strength 50% larger!**

HOWEVER: 36,000 km long single carbon nanotubes cannot now be grown

Even ONE continuous METER is beyond our current capability

So Cramer assumed rope woven from short fibers (like normal rope)

Assumes bonds between CNTs are as strong as bonds within CNTs

Not the case with normal fibers, not presently the case with CNTs

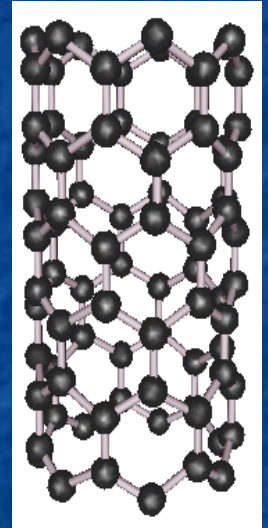

Also, Cramer's estimate of CNT strength = 3-10 times larger than figure I got from other experts

But we ARE in the ballpark, and "experts" have been wrong or superceded before

(i.e. I wouldn't invest in it yet, but not sure I'd bet against it either)

Overall conclusions about nano science fiction:

Biggest weakness has been its extrapolation of macro behavior to nanoscales:

Ignores rebalancing of forces. In particular: Nano importance of surface forces

Likely eliminates ideas such as classic nano-mechanical robot

But some of the BIG science fiction ideas may yet turn out to be correct:

Such as the very BIG space elevator idea becoming practical via nanotube cables

And even nanobots are plausible if ideas are suitably modified:

Forget about self-directed motion and "go with the flow"

Forget about nano-vision and just recognize when you arrive where you want

But this mimics biological function (even if that feels like cheating)

Bio also likely required to achieve self-replication (if not computation)

Bearing in mind that uncontrolled self-replication could end up being damned dangerous!

Credits / Acknowledgements

Funding for this class was obtained from the National Science Foundation (under their Nanoscience Undergraduate Education program).

This set of notes was authored by John C. Bean who also created all figures not explicitly credited above.

Copyright John C. Bean

(However, permission is granted for use by individual instructors in non-profit academic institutions)